

CRAFTSMAN®

Clicker Style Digi-Click™ TorqueWrench

Owner's Manual Model No's:
13918, 13919

SAFETY RULES

1. STUDY THIS BOOKLET CAREFULLY BEFORE ATTEMPTING TO OPERATE THIS WRENCH.
2. Never apply more torque than the maximum scale reading.
3. This torque wrench is designed for manual tightening of threaded fasteners only. **DO NOT USE IT AS A NUT-BREAKER OR FOR ANY OTHER PURPOSE.**
4. Over-torqued or defective fasteners and sockets may suddenly break. Ratchets that are improperly engaged, worn out, damaged, or over-torqued may slip or break. **TO PREVENT INJURY, KEEP PROPER FOOTING AND BALANCE AT ALL TIMES. DO NOT USE THE WRENCH IN PLACES FROM WHICH YOU MAY FALL OR SLIP, OR AROUND OPERATING MACHINERY.**
5. This wrench will not prevent you from applying more torque than set, it is not a torque limiting tool. The LCD display will flash "STOP" if you exceed either the lower or upper limit of intended use. At low settings the release is gentle and there usually is no audible 'click' signal. Learn how different amounts of torque 'feel', so you will reduce the possibility of damage and/or injury due to accidental over-torquing.
6. **APPLY FORCE TO THE GRIP ONLY. DO NOT USE 'CHEATER BARS'** (a piece of pipe placed over the hand grip).
7. There are no user-serviceable components inside the wrench. Disassembling the wrench or making any adjustments will result in the loss of accuracy, and will void the warranty.

OPERATING INSTRUCTIONS

Before adjusting the wrench to the desired torque setting, make sure that you are using the correct torque units. Torque values may be displayed in units of Inch Pounds, Foot Pounds, Newton Meters, or Centimeter Kilograms.

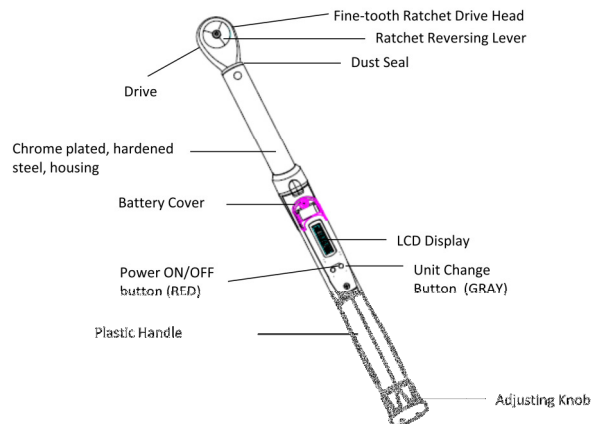

Your CRAFTSMAN DIGI-CLICK™ Torque Wrench is calibrated in Foot-Pounds (default on the LCD display) and can be changed to other units as desired.

WARNING: DO NOT turn the adjusting knob either below the lowest scale reading or above the highest scale reading. The LCD display will show torque settings beyond the calibrated upper and lower limits of your DIGI-CLICK™ torque wrench, these are intended for adjusting purposes only and are not within the calibrated range.

WARNING: DO NOT use the wrench when batteries are not installed or when batteries do not have sufficient power to operate the wrench

TO SET TORQUE

1. Press the red PWR button to turn the wrench on.
2. At initial power up, the LCD display will flash all icons twice and then show the current torque setting. When stored or not in use, the wrench should be set to less than 25% of the maximum capacity.

NOTE: The battery level indicator on the LCD display will indicate the remaining battery life.

3. Press the gray UNIT button to toggle through desired units (ft-lb, in-lb, N-m, kg-cm)
4. Pull the adjusting knob out to unlock the adjusting mechanism.
5. While holding the adjusting knob unlocked, turn it clockwise to increase the torque, and counterclockwise to decrease torque. Keep turning until the desired TARGET torque reading is displayed on the LCD screen.

6. If during a torque setting adjustment the intended TARGET value is exceeded on the LCD display, the torque wrench should be first adjusted back to below the TARGET value, and then back up to the intended TARGET value.
7. Lock the setting by releasing and, if necessary, pushing the adjusting knob in. The knob can be turned slightly back and forth without changing the torque setting to assure proper engagement of teeth in the locking mechanism.
8. Press and hold the red PWR button for 2 seconds to turn the wrench off. This torque wrench has an automatic shut off feature and will power down after 10 minutes of non-use.

NOTE: The TARGET torque setting and units will be saved after shut off. If the torque is adjusted while the power is off, the correct torque target will be displayed at the power on screen .

TO APPLY TORQUE

1. Attach the proper socket or other attachment to the drive. Set the reversing lever of the proper direction of the operation.

NOTE: If special attachments are used, torque setting must be corrected in accordance with the directions given below in the extensions section.

2. Place the socket or attachment onto the fastener to be torqued.
3. Utilizing the ratcheting head, you may 'spindown' the fastener until resistance is felt.
4. Holding the wrench **BY THE GRIP ONLY***, apply **SLOW AND STEADY** pull until a momentary release impulse or 'click' is felt. Release tightening pressure immediately when the release is felt.

WARNING: At low torque settings the release is gentle and there usually is no audible 'click' signal. Learn how the release feels BEFORE you torque to avoid accidental over-tightening or damage.

*When using long sockets or extensions, the wrench may be supported at the head (only at the head) with only negligible effects on accuracy.

5. The wrench resets automatically and is ready for the next operation.

EXTENSIONS

At times, it is impossible or impractical to use regular sockets, (a good example being the tightening of threaded tubing connectors) and a special attachment must be utilized. Such attachments change the calibration of the torque wrench, and it is necessary to calculate the correct settings using the following formulas.

NOTE: Regular socket extensions which extend directly under the drive head along the axis of rotation of the ratchet do not affect the calibration of the torque wrench.

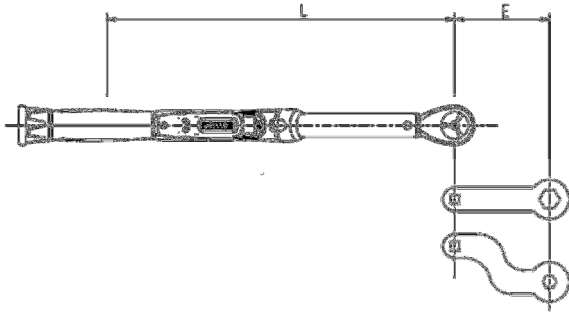

E – Effective Length of extension measured along the center line of the torque wrench

L – Lever length of the wrench – center of grip to center of drive

$$T(W) = T(E) \left(\frac{L}{L + E} \right)$$

$$T(E) = T(W) \left(\frac{L + E}{L} \right)$$

CARE AND MAINTENANCE

1. The CRAFTSMAN DIGI-CLICK™ Torque Wrench is a precision instrument and should be handled and stored with care. *It should never be used as a hammer or pry bar.*
2. DO NOT apply more torque than the rated capacity of the torque wrench. DO NOT use it as a nut-breaker!!
3. When the wrench is not in use, keep it set below 25% of capacity. If you leave the wrench set to over 50% of the wrench capacity for more than a few hours, set the wrench to the lowest setting and leave it for a few minutes before using it again.

4. The wrench is lubricated for life with a special lubricant. Do not oil it in any manner. The ratchet head may be lubricated as needed for smooth operation.
5. This wrench uses three (3) 1.5v (LR44 or equivalent) batteries.
6. To install and replace batteries as necessary, remove the battery cover by removing the screw on the battery cover, located to the left of the LCD. Place the new batteries with all three facing the same direction, the positive (flat) side facing the user. Replace the battery cover by tightening the screw for the battery holder.

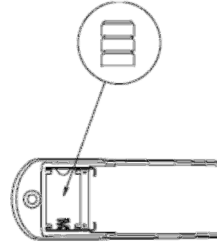

7. Remove batteries when wrench is stored for extended periods.
8. When not in use, store the torque wrench in its protective case.
9. The rubberized grip is not affected by petroleum products, but it will be damaged by Acetone and certain industrial solvents. It may be cleaned with a clean cloth wetted in mineral spirits or denatured alcohol. *Never immerse the wrench or any portion of it in any liquid.* Clean by wiping with a dry cloth.
10. Periodically, the wrench should be checked for accuracy. This should be done if the wrench is used frequently or is subjected to abnormal handling or storage. In assembly line type of usage, the wrench should be checked every 5,000 torque applications. Calibration service is available by returning it to your Sears store.
11. With the exception of the ratchet mechanism, the wrench is not user serviceable. Return it to the nearest Sears store for service.
12. The ratchet head may be repaired by ordering repair kits #44525 for 3/8" drive and #43445 for 1/2" drive models from Sears, Dept. 98, Source 449.3

SPECIFICATIONS

Operating Temperature Range	40°F - 110°F (5°C - 42°C)	
Model No.	13918	13919
Drive	3/8" Ratchet	1/2" Ratchet
Calibrated Capacity†	5-80 ft-lbs 60 – 960 in-lbs 6.78 – 108.48 N-m 69.1 – 1105.6 kg-cm	25-250 ft-lbs 300 – 3000 in-lbs 33.9 – 339 N-m 345.5 – 3455 kg-cm
Increments & Display Resolution	0.25 ft-lbs 3.0 in-lbs 0.25 N-m 3.0 kg-cm	0.5ft-lbs 6.0 in-lbs 0.5 N-m 6.0 kg-cm
Dimensions	19.3" x 1.6" x 2.2"	23.3" x 1.6" x 2.4"
Weight, lb/oz (gm)	1/11 (767)	2/7 (1110)
Lever Length*	15.0"	18.9"

† LCD will display settings above and below the calibrated range, for adjusting purposes only.

*Center of drive to center of handle

ACCURACY: ±4% on clockwise or right-hand readings greater or equal to 20% of capacity. Complies with American National Standard B107.14M and International Standard ISO 6789

NOTE: The wrench will not actuate or 'click' when used in the counter-clockwise or left-hand direction

FULL 90-DAY WARRANTY ON CRAFTSMAN DIGI-CLICK™ TORQUE WRENCH

If this electronic Craftsman DIGI-CLICK™ torque wrench fails due to a defect in material or workmanship within 90 days from the date of purchase, return it to any Sears store or other Craftsman outlet for free repair (or replacement if repair proves impossible).

If this electronic Craftsman DIGI-CLICK™ torque wrench needs re-calibration within 90 days from the date of purchase, return it to any Sears Parts & Repair Service Center, Sears store, or other Craftsman outlet for free recalibration

This warranty gives you specific legal rights, and you may also have other rights which vary from state to state.

P/N: 10345A

06-2012