

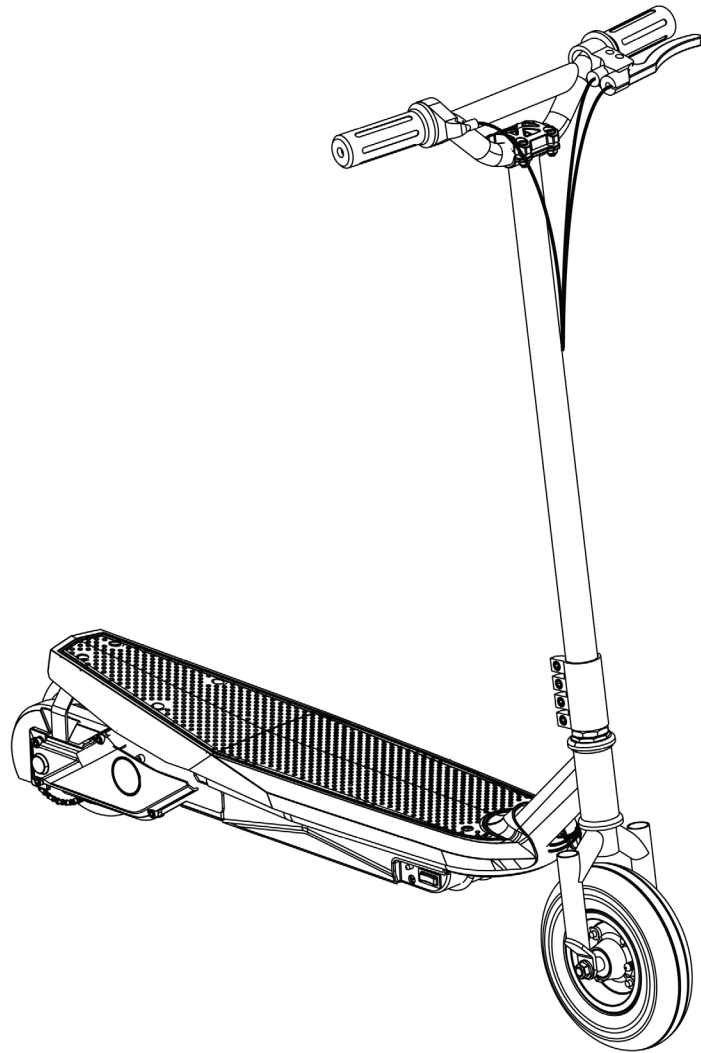

**PULSE  
PERFORMANCE  
PRODUCTS**

---



# **ELECTRIC SCOOTER OWNER'S MANUAL**

**FOR USE WITH THE FOLLOWING PULSE PERFORMANCE PRODUCTS™ SCOOTERS**

- SONIC

**DO NOT RETURN TO STORE! QUESTIONS OR COMMENTS?  
CALL (866)-434-6067**

NOTE: Manual illustrations are for reference purposes only. Illustrations may not reflect the exact appearance of the actual product. Specifications are subject to change without notice.

# Table of Contents

Safety and Warnings	2-3
Before You Start	4
Assembly	5-6
Hardware Maintenance	7
Before You Ride	7
Repair and Maintenance	8-12
Troubleshooting	13
Scooter Components	14
Warranty	15

## Safety and Warnings

**WARNING:** Riding an electric scooter can be a dangerous activity. Certain conditions may cause components to fail without fault of the manufacturer. Scooter can and is intended to move and it is therefore possible to lose control, fall off and/or get into dangerous situations that no amount of care, instruction or expertise can eliminate. If such a thing does occur you can become seriously injured or die, even when using safety equipment and other safety precautions. **RIDE AT YOUR OWN RISK AND ALWAYS USE COMMON SENSE.**

This manual contains many warnings and cautions concerning the consequences of failing to inspect, maintain or properly use your electric scooter. Since any incident can result in serious injury or even death, we do not repeat the warning of possible serious injury or death each time such a possibility is mentioned in this manual.

### APPROPRIATE RIDING ATTIRE

Always wear proper protective equipment such as:

- Approved safety helmet. (Helmet may be legally required by local law or regulation in your area.)
- Elbow pads and knees pads
- Long sleeved shirt, long pants
- Gloves
- Lace up shoes with rubber soles, never ride barefooted or in sandals, and insure that shoelaces are tied and kept out of the way of the wheels and drive system.

### RIDER USE AND PARENTAL SUPERVISION

RIDER MUST NOT EXCEED THE WEIGHT LIMIT OF 150 pounds (68 kg). Rider weight does not always mean a person's size is appropriate to fit or maintain control of the scooter.

This manual contains extremely important safety information. It is your responsibility to completely review this information and make sure that all riders understand all warnings, cautions, instructions and safety topics and assure that all riders are able to safely and responsibly use this scooter. Pulse Performance Products™ advises that you periodically review and reinforce all information in this manual with all riders, and that you inspect and maintain your scooter to insure their safety.

The recommended rider age is 13 and older. Any rider that is unable to fit comfortably on the scooter should never attempt to ride it. A parent's decision to allow their child to use scooter should be based on the child's maturity, skill and their ability to follow rules.

Do not touch the motor or brakes on the scooter when in use or directly after use as these parts can become extremely hot.

Keep this scooter away from small children and remember that it is intended for use only by persons who are, at a minimum, completely competent and comfortable while operating this product.

### RIDING PRACTICES AND CONDITIONS

Check and obey any local laws or regulations which may affect the locations where the electric scooter may be used.

Always ride defensively. Watch out for obstacles that could catch your wheel or force you to turn suddenly or lose control. Be careful to avoid pedestrians, other wheeled products (such as skaters, skateboards, scooters, bikes, etc.), children or animals who may enter your path. Always respect the rights and property of others.

Do not activate the speed control on the hand grip unless you are on the scooter and in a safe, outdoor environment that is suitable for riding.

Do not attempt or perform stunts or tricks on this electric scooter. This product is not made to withstand abuse from jumping, curb grinding or any other type of misuse or stunts.

# Safety and Warnings

Maintain a hold with both hands on the handlebars at all times.

Never allow more than one person at a time to ride the scooter.

Never use near steps, water, or swimming pools.

Keep your fingers and other body parts away from the chain, motor, steering system, wheels and all other moving components.

Never ride while using a cell phone or wearing headphones.

Never hitch on to or with another vehicle or pull anyone or anything.

Never immerse the scooter in water; electrical and drive components could be damaged by water or create other possible unsafe conditions.

Ride only on flat, dry surfaces such as pavement or level ground without loose debris, such as sand, leaves, rocks or gravel. Water, mud, ice, bumpy, uneven, slick, or rough surfaces could impair traction and contribute to possible loss of control. Avoid excessive speeds that can occur from downhill rides which could cause loss of control.

Do not ride at night or in areas of limited visibility.

Do not ride indoors or on surfaces that could become damaged such as carpet or flooring.

Before each cycle of operation, the operator shall perform the preoperational checks specified by the manufacturer; that all guards and pads originally supplied by the manufacturer are in proper place and in serviceable condition.

That any and all axle guards, chain guards, or other covers or guards supplied by the manufacturer are in place and in serviceable condition.

Persons with the following conditions shall be cautioned not to operate: Those with heart conditions, pregnant women, persons with head, back, or neck ailments, or prior surgeries to those areas of the body. Persons with any mental or physical conditions that may make them susceptible to injury or impair their physical dexterity or mental capabilities to recognize, understand, and perform all of the safety instructions and to be able to assume the hazards inherent in unit use.

Maximum operating speed is 13 MPH (20 KM/H).

Before each ride the following checks will need to be performed to the scooter:

- Ensure that the brake system is functioning properly.
- That all components are properly secured and are functioning according to manufactures specifications.
- Components shall be maintained and repaired in accordance with the manufacturers authorized replacement parts with installation performed by dealers or other skilled individuals.

## USING THE BATTERY CHARGER

The battery charger should be regularly examined for damage to the cord, plug, enclosure and other parts. In the event of such damage, if any is found, the scooter should not be charged until the battery charger has been repaired or replaced.

Use only with the supplied recommended battery charger.

Always use caution when charging.

The battery charger is not a toy and should be operated by an adult.

Never operate battery charger near flammable materials or liquids.

Disconnect the battery charger and unplug from scooter when not in use.

Do not exceed recommended charging time.

Always disconnect the battery charger from the scooter prior to wiping down and cleaning with any liquid.

**FAILURE TO HEED TO THE WARNINGS LISTED ABOVE INCREASES RISK OF POTENTIAL SERIOUS INJURY. USE THE APPROPRIATE CAUTION WHEN RIDING AND ALWAYS WEAR PROTECTIVE GEAR.**

# Before You Start

**⚠ WARNING:** Remove all packing and items from the display box. Make sure that the power switch is turned "OFF" before assembling the scooter.

## Estimated Assembly Time

- Allow up to 25 minutes for assembly, not including initial charge time.
- Allow up to 14 hours for the initial charge (see page 6 for charging information).

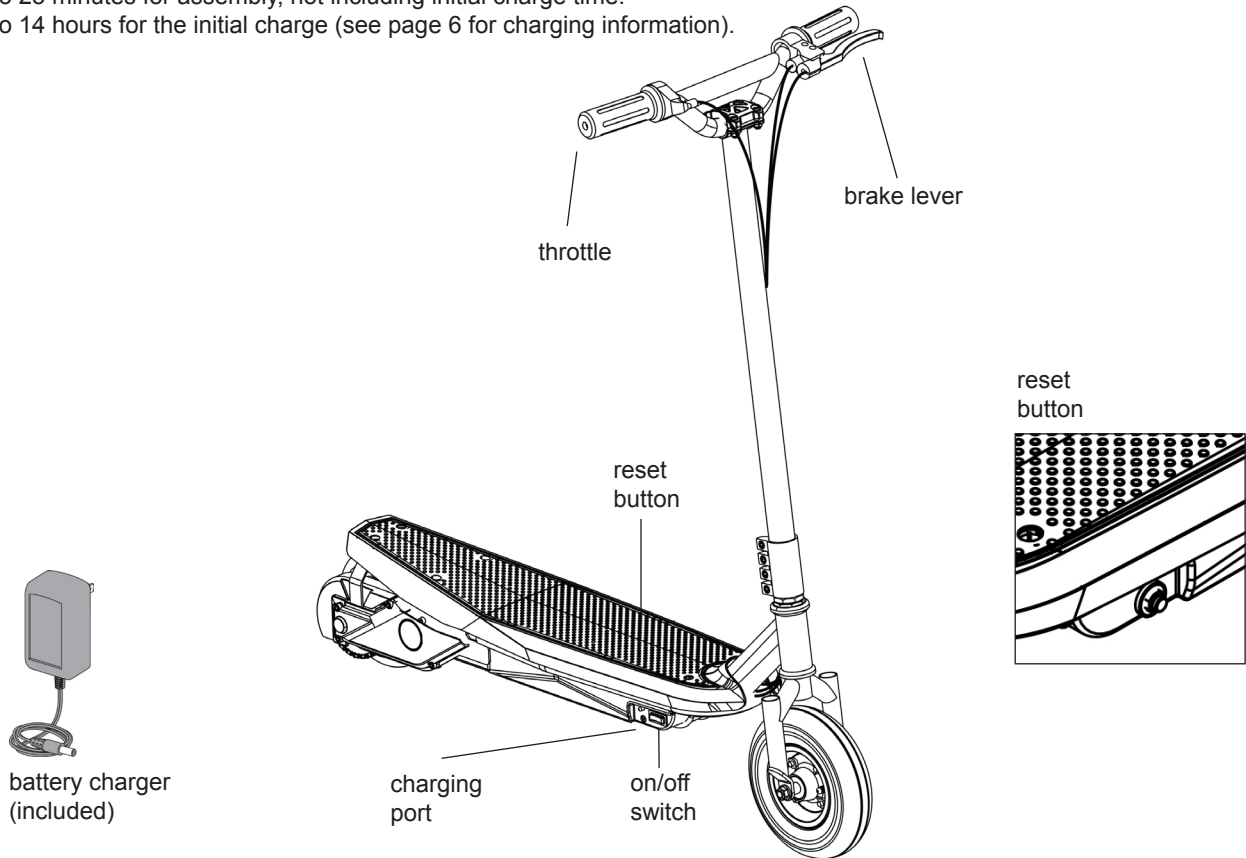

## Required Tools

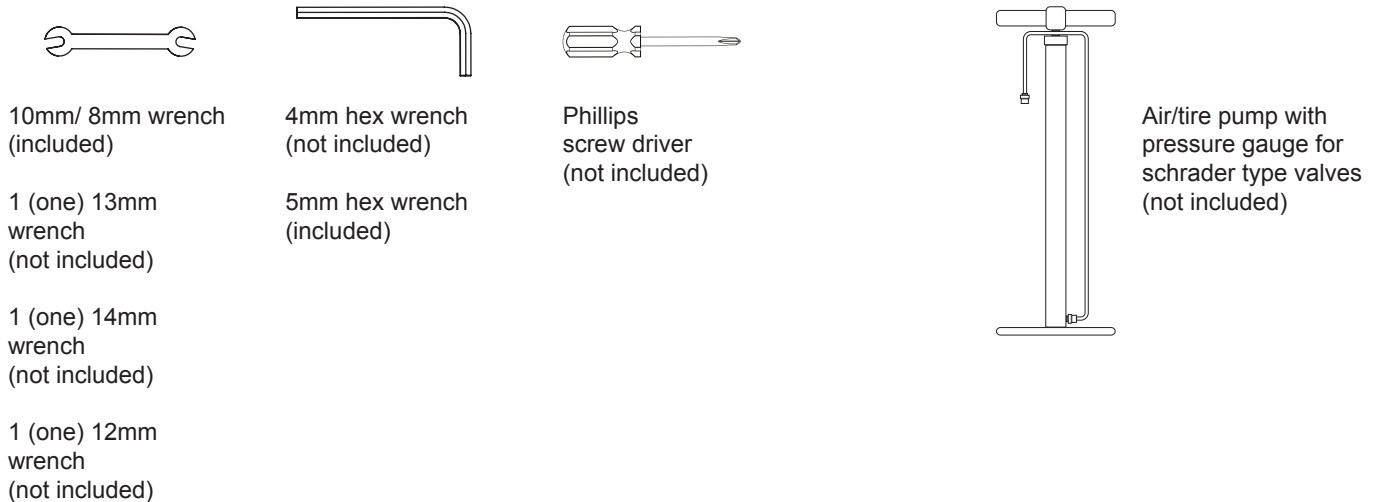

**⚠ WARNING:** DO NOT USE NON-PULSE PRODUCTS WITH YOUR PULSE ELECTRIC SCOOTER. This scooter has been built to specific Pulse Performance Scooter design specifications and should not be modified. Altering of the original components may or may not be compatible with the design and will void the warranty.

# Assembly

## Handlebar Steer Tube Assembly

Tools required: 5mm hex wrench, 10mm wrench

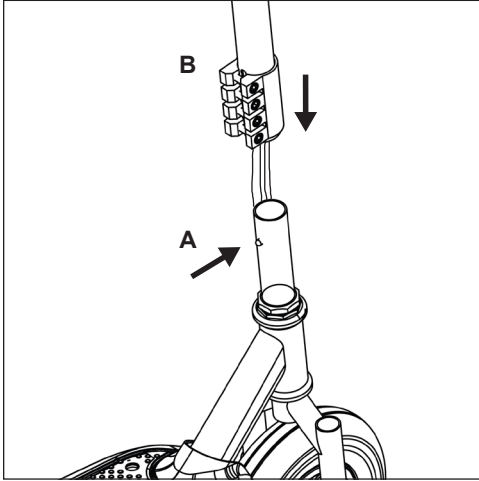

1. Depress the push button located on the rear of the fork and insert the handlebar steer tube onto the fork. The push button should align with the locator hole in the handlebar steer tube and lock the steer tube securely in place.

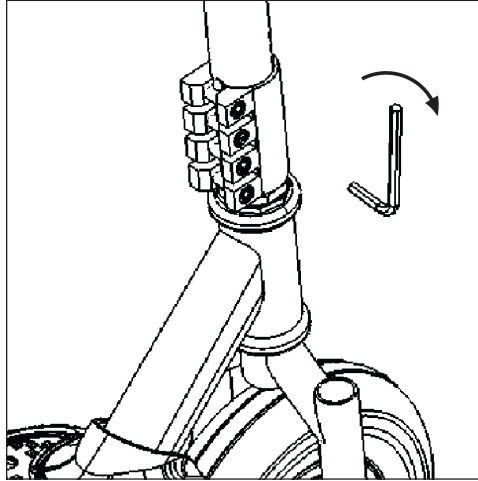

2. Tighten the bolts with the 5mm hex wrench, evenly and securely.

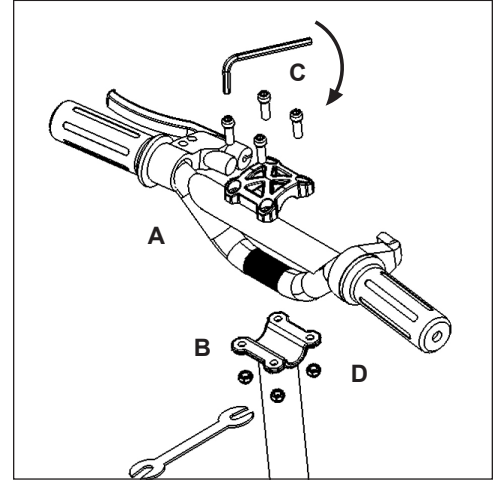

3. Align handlebars both vertically and horizontally (a) onto handlebar steer tube clamp (b) install handlebar clamp and hardware (c&d) and tighten evenly and securely with the 5mm hex wrench and 10mm wrench.

## Tire Inflation

Tools required: Air/tire pump

Tires are inflated to the maximum PSI prior to shipping however some air pressure maybe lost between the manufacture date and your purchase date.

Using a hand pump with a Schrader-type valve and pressure gauge inflate the tires to the recommended PSI as called out on the tire sidewall. It is not recommended to use pressurized system similar to the ones found at gas stations as these are designed to inflate automobile tires that have much higher air capacity volumes.

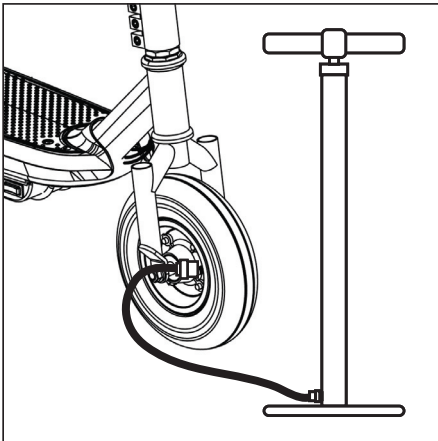

**FRONT TIRE PSI: 36**

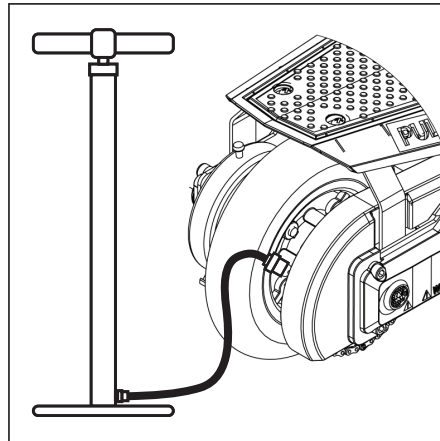

**REAR TIRE PSI: 60**

**ENSURE TIRES ARE AT THE CORRECT PSI BEFORE RIDING THE SCOOTER.**

**⚠ WARNING:** It is important to routinely check and maintain tire pressure as this directly impact the safety and performance of the scooter. Do not overinflate tire as this can cause damage to the tire or the wheel.

# Assembly

## Charging the Battery

**⚠ WARNING:** Batteries must be fully charged before you ride your electric scooter.

Required components: Battery charger

- Initial battery charge time - 14 hours
- Recharges after initial charge - Up to 10 hours
- When scooter is not in regular use batteries need to be charged on a monthly basis to maximize performance.

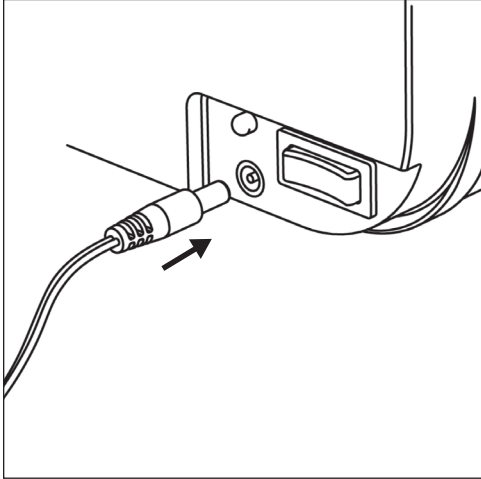

1. Make sure power switch is in the OFF position before plugging in the charger. Insert charger into charging port on the right side of the battery box.

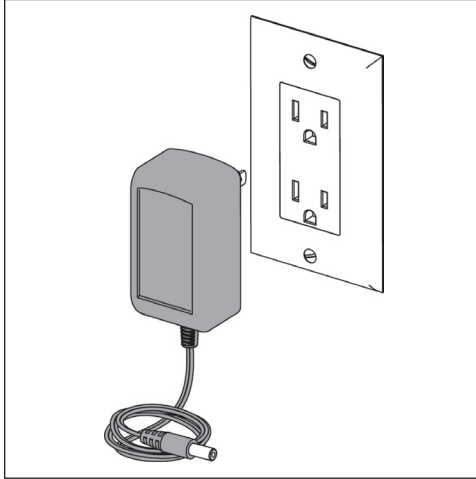

2. Plug the battery charger into a wall power outlet. The light on the charger housing should illuminate. Red LED light indicates battery is charging and a green LED light indicates battery is fully charged.

**⚠ WARNING:** Any changes or modifications to this unit not expressly approved by the party responsible for compliance could void the user's authority to operate the equipment.

This device complies with Part 15 of the FCC Rules. Operation is subject to the following two conditions: (1) This device may not cause harmful interference, and (2) this device must accept any interference received, including interference that may cause undesired operation.

NOTE: This equipment has been tested and found to comply with the limits for a Class B digital device, pursuant to part 15 of the FCC Rules. These limits are designed to provide reasonable protection against harmful interference in a residential installation. This equipment generates, uses and can radiate radio frequency energy and, if not installed and used in accordance with the instructions, may cause

harmful interference to radio communications. However, there is no guarantee that interference will not occur in a particular installation. If this equipment does cause harmful interference to radio or television reception, which can be determined by turning the equipment off and on, the user is encouraged to try to correct the interference by one or more of the following measures:

- Reorient or relocate the receiving antenna.
- Increase the separation between the equipment and receiver.
- Connect the equipment into an outlet on a circuit different from that to which the receiver is connected.
- Consult the dealer or an experienced radio/TV technician for help.

**⚠ WARNING:** Do not use this product for the first time until you have charged the battery for at least 14 hours. Failure to follow these instructions may damage your product and void your warranty.

Note: Do not store the battery in temperatures above 70°F (21°C) or below 32°F (0°C).

Note: The charger has a small window with one LED light that indicates the charge status. Refer to the illustration on the charger unit for the actual "charging" and "charged" status indication. Your charger may get warm during use; this is normal and is no cause for concern.

Note: Batteries must be recharged at least once a month even when the scooter is not in use. Failure to do so may result in batteries that will no longer accept a charge.

# Hardware Maintenance

## Brake

Check the brakes for proper function. When you squeeze the lever, the brake should provide positive braking action. When you apply the brake with the speed control on, the brake cut off switch should stop the motor. Make sure that the brakes are not rubbing when lever is not being applied.

## Frame, Fork and Handlebars

Check for cracks or broken connections. Although broken frames are rare, it is possible for aggressive rider to run into a curb or wall and bend or break a frame. Get in the habit of inspecting your scooter on a regular basis.

## Tires

Periodically inspect the wheels for excess wear and always check and maintain tire inflation.

## Safety Gear

Always wear proper protective gear such as an approved safety helmet. Elbow pads and knee pads are recommended. Always wear athletic shoes (lace up shoes with rubber soles), never ride barefooted or in sandals, and keep shoelaces tied and out of the way of the wheels, motor and drive system.

## Battery

Make sure the power switch is turned off whenever the scooter is not in use. Never store the product in freezing or below freezing temperatures! Freezing will permanently damage the battery.

# Before You Ride

**Before you ride always check and for the following:**

## Safety Gear

Always wear proper protective gear such as:

- Approved safety helmet. (Helmet may be legally required by local law or regulation in your area.)
- Elbow pads and knees pads
- Long sleeved shirt, long pants
- Gloves
- Lace up shoes with rubber soles.

## Brake

Check the brakes for proper function. When lever is squeezed it should slow/stop the rear wheel without excessive effort. When you apply the brake with the throttle on, the brake cut off switch should stop the motor. Make sure that the brakes are not rubbing when the lever is not being squeezed. Do not ride the scooter if the brakes are not functioning properly.

## Throttle

Make sure that before throttle is twisted that you are in an open and safe area to ride, you are balanced on the scooter and have both hands on the handlebar controls.

## Tires

Inspect the wheels for excess wear and replace if necessary. Always check and maintain tire inflation.

## Frame, Fork and Components

Always carefully inspect your scooter before you ride. Check for cracks, broken worn or loose components which should be repaired or replaced before you ride.

## Battery

Always make sure the power switch is in the "off" position whenever the scooter is not in use. Never store the product in freezing or below freezing temperatures. These low temperatures will permanently damage the battery.

**⚠ WARNING:** Always ensure that you are in a safe open area to ride before you engage the throttle. Never twist the throttle without being on the scooter in a balanced, ready to ride position with both hands on the handlebar controls. Once the power switch is placed in the "on" position the scooter will move when the throttle is twisted.

Failure to follow these instructions may damage your scooter and void your warranty.

# Repair and Maintenance

**⚠ WARNING:** Turn the power switch “OFF” before conducting any maintenance procedures.

## Adjusting the Brakes

Tools required: 10mm wrench

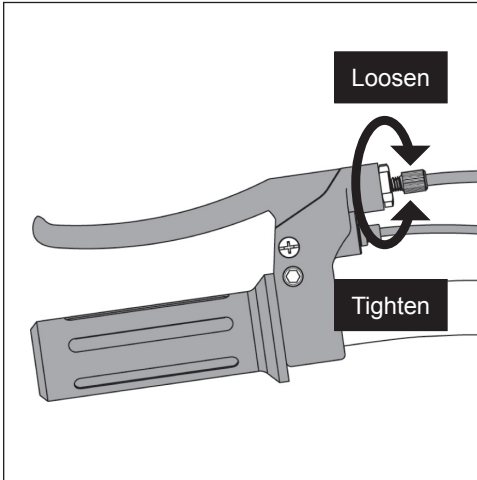

1. To adjust the brake cable thread clockwise (loosen) or counter clockwise (tighten) the adjuster barrel on the brake lever. Only turn the barrel in small increments until the desired adjustment is reached. If brake continues to need further adjustment proceed to the next step.

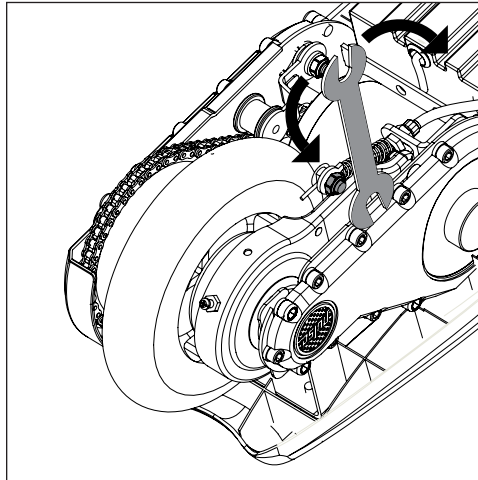

2. If the brake cable is still either too tight or too loose use a 10mm wrench to loosen the brake cable pinch bolt for further adjustment on the cable. Ensure that the 10mm nut is securely tightened after the adjustment is made.

**⚠ WARNING:** The brake could be capable of locking up and skidding the rear wheel if not applied correctly. Always try and avoid skidding as this could cause you to lose control of the scooter and will cause damage to the rear tire. Practice using the brake in an unobstructed open area to become familiar with its function and can make smooth controlled stops.



# Repair and Maintenance

## Chain and Rear Wheel Replacement (Continued)

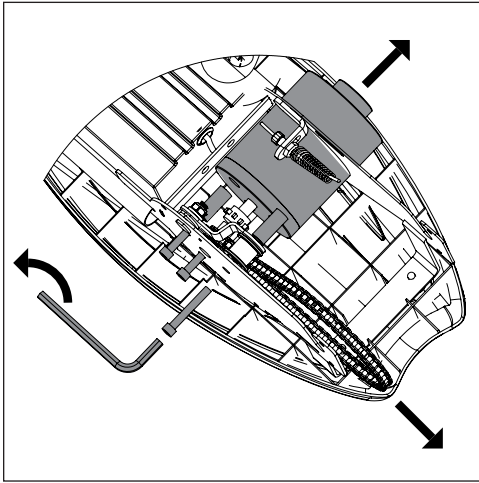

5. If replacing the chain, remove the motor bolts with a 4mm hex wrench. Slide motor out of the frame slightly so that there is enough room to remove/replace the chain onto the motor gear. Replace spacers and retighten bolts.

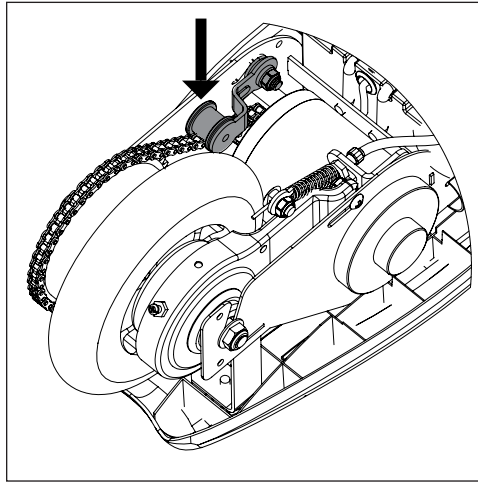

6. Place the chain under tensioner wheel and onto the rear chain wheel gear and install replacement wheel into the frame. Do not tighten axle nuts yet. Install brake arm hardware, do not tighten yet.

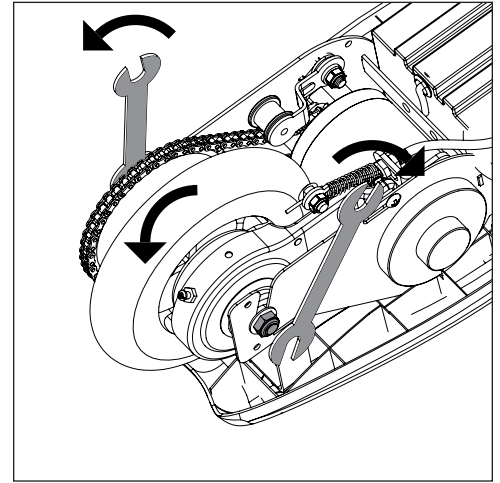

7. Ensure axle hardware is seated correctly against the frame. After tightening axle nuts with a 14mm wrench and a 12mm wrench check wheel alignment and the tracking of the chain by rotating the wheel counter clockwise with your hand. Wheel should spin freely and easily.

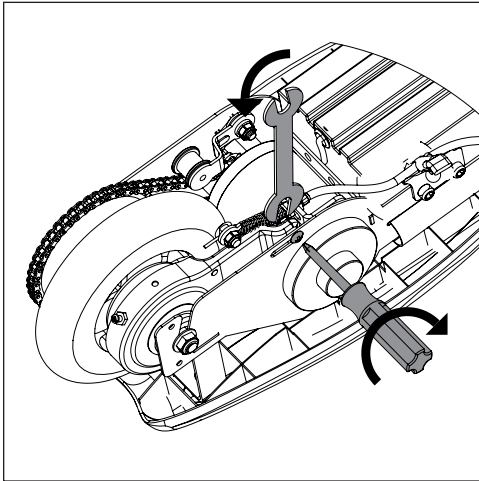

8. Retighten the brake arm bolt with a Phillips screwdriver & 8mm wrench.

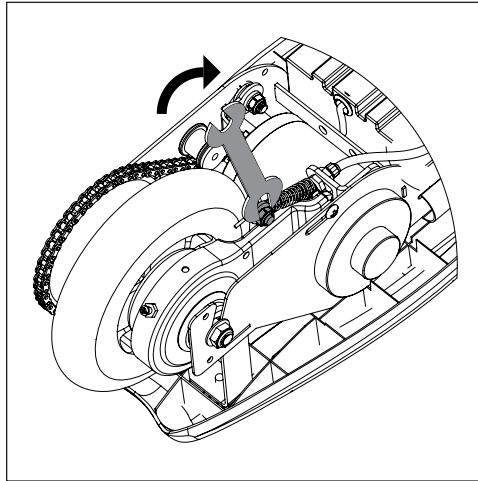

9. Retighten brake cable pinch nut with 10mm wrench. Refer to the instructions on page 8 for proper adjustment.

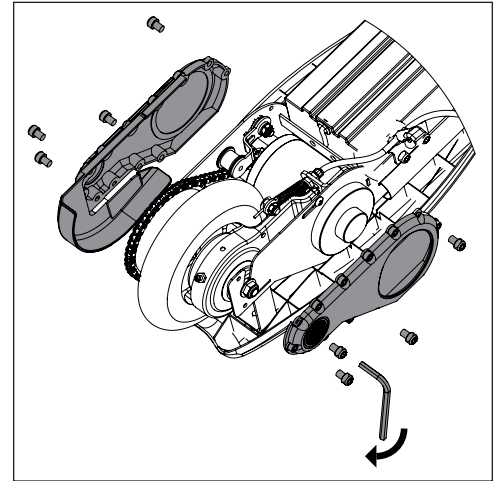

10. Reinstall side covers with a 4mm hex wrench. Do not over tighten bolts.

**⚠ WARNING:** If you do not feel comfortable performing the adjustments, consult an authorized Pulse Performance Products™ customer service representative or a qualified bicycle or motorcycle mechanic.

# Repair and Maintenance

## Front Wheel Replacement

Tools required: 13mm wrench, 14mm wrench

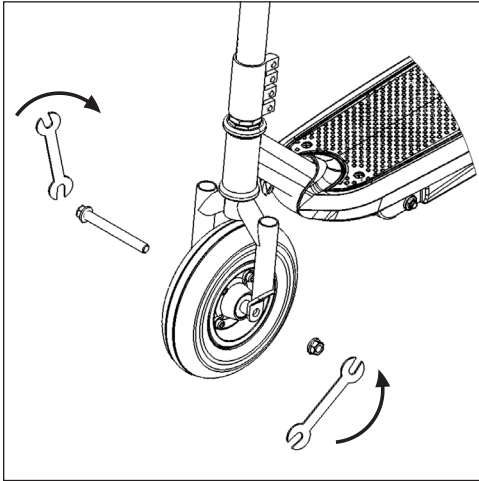

1. Using a 13mm wrench and a 14mm wrench loosen and remove the front axle by turning the wrenches counter clockwise.

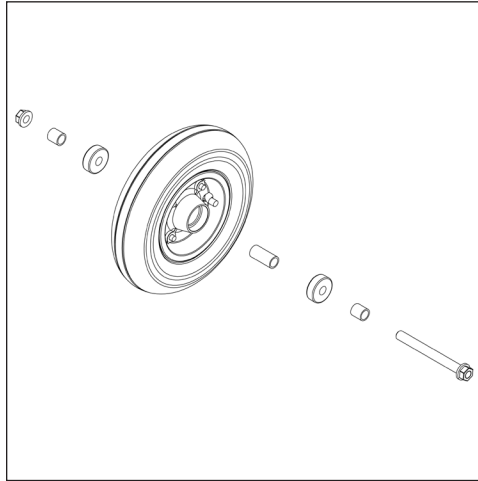

2. Reinstall new replacement wheel ensuring to note the order and location of all components.

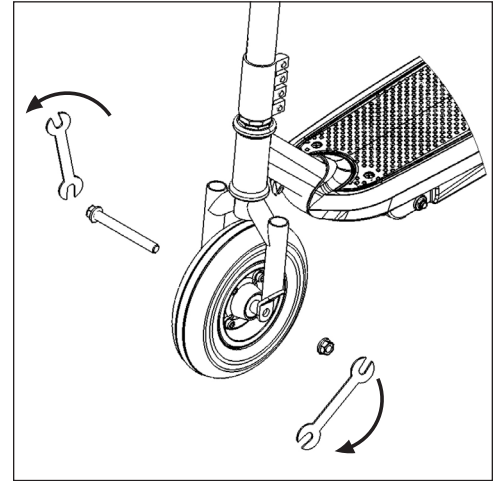

3. Reinstall hardware and tighten clockwise with a 13mm wrench and a 14mm wrench.

---

## Battery Care and Disposal

---

Do not store the battery in temperatures above 70°F (21°C) or below 32°F (0°C).



THIS SCOOTER CONTAINS SEALED LEAD ACID BATTERIES WHICH MUST BE RECYCLED IN ACCORDANCE TO YOUR LOCAL AND STATE LAWS. PLEASE CAREFULLY READ AND UNDERSTAND THE FOLLOWING DISPOSAL INSTRUCTIONS:

Disposal: This product contains sealed lead acid batteries which must be disposed or recycled in an environmentally safe manner. Do not dispose of the batteries in your household trash. Do not dispose of the batteries in a fire, this could cause the batteries to leak or explode. The incineration, disposal in landfill and or placing sealed lead acid batteries with household trash is prohibited by law in most areas. Return exhausted batteries to a state or federal approved lead acid battery recycler or check with your local retailer of vehicle batteries.

**⚠ WARNING:** Do not mix old and new batteries. Do not mix alkaline, standard (carbon-zinc), or rechargeable (nickel-cadmium) batteries.

Do not store the battery in temperatures above 70°F (21°C) or below 32°F (0°C).

---

## Repair and Maintenance

---

### Battery Charger

Only use the supplied battery charger. If battery charger is damaged discontinue use immediately and replace with a Pulse Performance Scooter recommended battery charger.

### Wheels

Wheels and drive system components are subject to normal wear and tear. It is the responsibility of the user to regularly inspect wheels for excess wear and adjust and replace drive train components as required. Always check and maintain proper tire inflation.

### Replacement Parts

Most of the common replacement parts are available for purchase on line at [www.pulsescooters.com](http://www.pulsescooters.com).

### Repair Help

- Check online at [www.pulsescooters.com](http://www.pulsescooters.com).
- Call (866) 434-6067 to speak with a customer service representative

**⚠ WARNING:** Make sure to wash your hands after handling batteries as they contain lead compounds.

# Troubleshooting

Problem	Possible Cause	Solution
Scooter will not run.	Battery is not charged.	Fully charge the battery. First charge should be 14 hours and up to 10 hours for recharges.
	Wires or connectors are loose or unplugged.	Check to ensure that charger is tightly plugged into both the wall and the scooter.
Scooter run time is short.	Battery requires charging.	Fully charge the battery. First charge should be 14 hours and up to 10 hours for recharges.  Check to ensure that battery charger is tightly plugged into both the wall and the scooter.
	Battery will not accept full charge.	Make sure power flow to the wall outlet is on.  Battery may need to be replaced. Even with proper care, rechargeable batteries do not last forever. The average rechargeable battery life is 1 to 2 years depending on scooter conditions and use. Replace only with Pulse Performance Products™ replacement batteries.
	Brakes are not adjusted correctly.	Refer to the instructions on adjusting the brakes on page 8.
Scooter suddenly stops working.	Reset button has tripped.	The reset button (on the left side of the battery box) will automatically trip and turn off the power if the motor is overloaded.  An excessive overload (steep incline or too heavy of a rider) could have caused the motor to overheat and tripped the breaker. If this occurs (scooter suddenly stops running) wait a few seconds and then push the reset button in to reset the circuit. Avoid repeatedly tripping the breaker.  Check all wires and connectors to make sure they are connected and tight.
		Apply a lubricant to the chain.
Scooter makes grinding or loud noises when motor is running.	Chain is dry.	Apply a lubricant to the chain.
Scooter runs sluggishly.	Brakes are not adjusted correctly.	Refer to the instructions on adjusting the brakes on page 8.
	Scooter is overloaded.	Make sure you do not overload the scooter by exceeding the 150 lbs. (68 kg.) maximum weight limit, going up steep inclines or towing objects behind the scooter. Avoid overloading the scooter as this will prematurely wear out the batteries and componentry.
	Unsuitable riding conditions.	Ride only on solid, flat, clean and dry surfaces such as pavement or level ground.

# Scooter Components

## part description

- 1 Frame
- 2 Motor
- 3 Front Fork
- 4 Headset
- 5 Clamp
- 6 Right Side Cover
- 7 Kickstand
- 8 Battery Box
- 9 Deck
- 10 Rear Wheel
- 11 Left Side Cover
- 12 Front Wheel
- 13 Chain
- 14 Brake
- 15 Throttle
- 16 Brake Lever
- 17 Controller
- 18 Battery
- 19 Steer Tube
- 20 Handlebar
- 21 Handlebar Clamp
- 22 Charger Port
- 23 Reset Button
- 24 On/Off Switch
- 25 Chain Wheel
- 26 Chain Tensioner

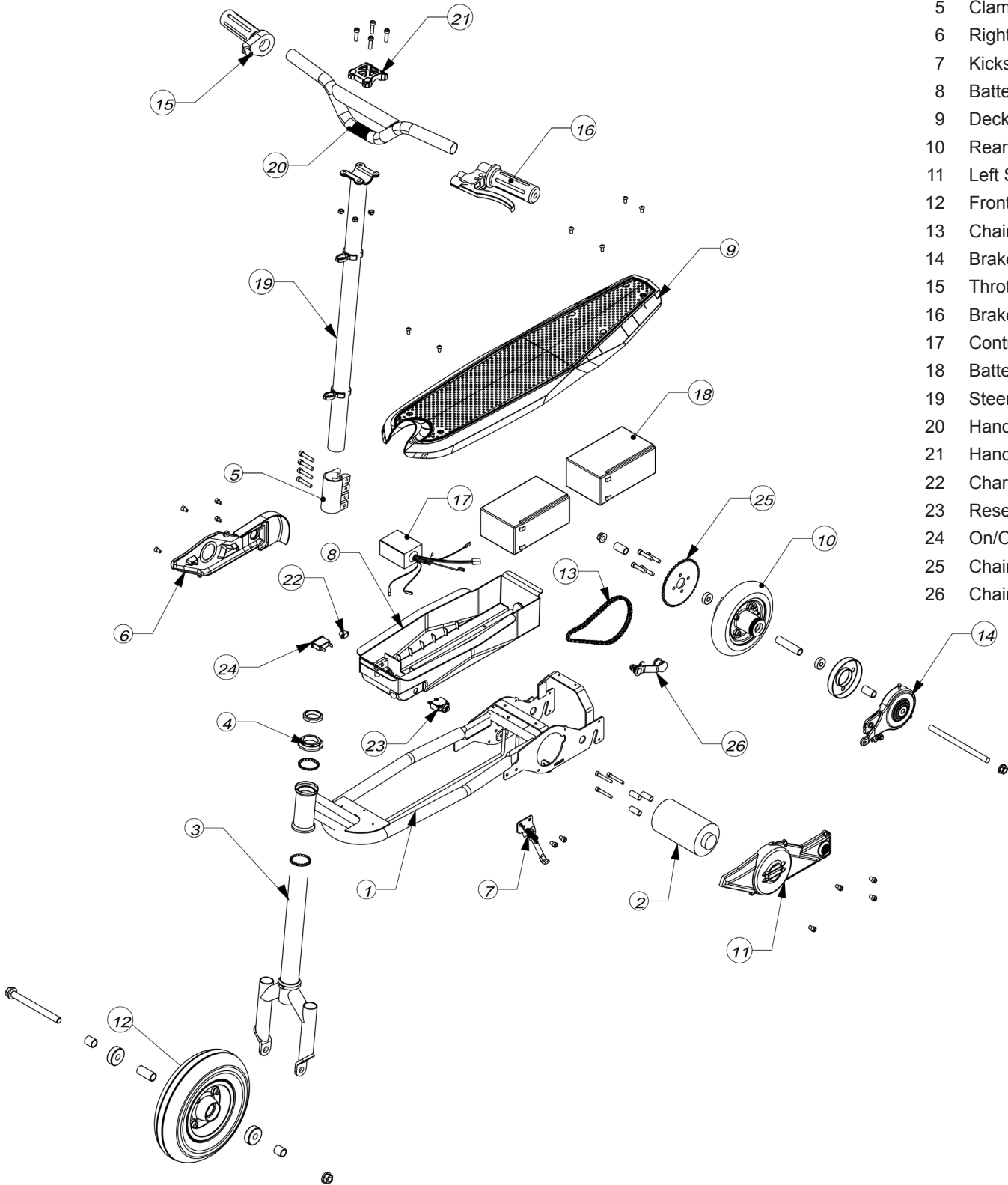

# Warranty

---

## Pulse Performance Products™ Limited Warranty

---

The manufacturer warrants this product to be free of manufacturing defects for a period of 90 days from the date of purchase. This Limited Warranty does not cover normal wear and tear, tires, cables, or any damage, failure or loss caused by improper assembly, maintenance, storage or use of this Pulse Performance Products™ electric scooter.

This Limited Warranty will be void if the product is ever:

- used in a manner other than for recreation or transportation
- modified in any way
- used as a rental

The manufacturer is not liable for incidental or consequential loss or damage due directly or indirectly to the use of this product.

Pulse does not offer an extended warranty. If you have purchased an extended warranty, it must be honored by the store at which the scooter was purchased from.

For your records, keep your original sales receipt with this manual.

---

### **SB 1918 (CALIFORNIA) DECLARATION**

YOUR INSURANCE POLICIES MAY NOT PROVIDE ANY COVERAGE FOR ACCIDENTS INVOLVING THE USE OF THIS SCOOTER. TO DETERMINE IF ANY COVERAGE IS PROVIDED CONTACT YOUR INSURANCE COMPANY OR INSURANCE AGENT.

---



**PULSE  
PERFORMANCE  
PRODUCTS**



[facebook.com/pulseperprod](https://facebook.com/pulseperprod)



[twitter.com/pulseperprod](https://twitter.com/pulseperprod)

---

Pulse Performance Products™

A Division of Bravo Sports™  
12801 Carmenita Rd.  
Santa Fe Springs, CA 90670

© 2012-2013 Pulse Performance Products™ - All Rights Reserved