



2.7AT

TREADMILL OWNER'S MANUAL



Read the TREADMILL GUIDE before using this OWNER'S MANUAL.

IMPORTANT PRECAUTIONS



SAVE THESE INSTRUCTIONS

When using an electrical product, basic precautions should always be followed, including the following: Read all instructions before using this treadmill. It is the responsibility of the owner to ensure that all users of this treadmill are adequately informed of all warnings and precautions. If you have any questions after reading this guide, contact Customer Tech Support at the number listed on the back panel of the OWNER'S MANUAL.

This treadmill is intended for in-home use only. Do not use this treadmill in any commercial, rental, school or institutional setting. Failure to comply will void the warranty.

 **DANGER****TO REDUCE THE RISK OF ELECTRICAL SHOCK:**

Always unplug the treadmill from the electrical outlet immediately after using, before cleaning, performing maintenance and putting on or taking off parts.

 **WARNING****TO REDUCE THE RISK OF BURNS, FIRE, ELECTRICAL SHOCK OR INJURY TO PERSONS:**

- Never use the treadmill before securing the safety tether clip to your clothing.
- If you experience any kind of pain, including but not limited to chest pains, nausea, dizziness, or shortness of breath, stop exercising immediately and consult your physician before continuing.
- When exercising, always maintain a comfortable pace.
- Do not wear clothes that might catch on any part of the treadmill.
- Always wear athletic shoes while using this equipment.
- Do not jump on the treadmill.
- At no time should more than one person be on treadmill while in operation.
- This treadmill should not be used by persons weighing more than specified in the OWNER'S MANUAL WARRANTY SECTION. Failure to comply will void the warranty.
- When lowering the treadmill deck, wait until rear feet are firmly on the floor before stepping on the deck.
- Disconnect all power before servicing or moving the equipment. To clean, wipe surfaces down with soap and slightly damp cloth only; never use solvents. (See MAINTENANCE)
- The treadmill should never be left unattended when plugged in. Unplug from outlet when not in use, and before putting on or taking off parts.
- Do not operate under blanket or pillow. Excessive heating can occur and cause fire, electric shock, or injury to persons.
- Connect this exercise product to a properly grounded outlet only.

WARNING

TO REDUCE THE RISK OF BURNS, FIRE, ELECTRICAL SHOCK OR INJURY TO PERSONS:

- At NO time should children under the age of 13 or pets be within 10 feet of the machine.
- At NO time should children under the age of 13 use the treadmill.
- Children over the age of 13 or disabled persons should not use the treadmill without adult supervision.
- Use the treadmill only for its intended use as described in the treadmill guide and owner's manual.
- Do not use other attachments that are not recommended by the manufacturer. Attachments may cause injury.
- Never operate the treadmill if it has a damaged cord or plug, if it is not working properly, if it has been dropped or damaged, or immersed in water. Contact tech support at the number on the back panel to schedule service.
- Keep power cord away from heated surfaces. Do not carry this unit by its supply cord or use the cord as a handle.
- Never operate the treadmill with the air opening blocked. Keep the air opening clean, free of lint, hair, and the like.
- To prevent electrical shock, never drop or insert any object into any opening.
- Do not operate where aerosol (spray) products are being used or when oxygen is being administered.
- To disconnect, turn all controls to the off position, then remove plug from outlet.
- Do not use treadmill in any location that is not temperature controlled, such as but not limited to garages, porches, pool rooms, bathrooms, car ports or outdoors. Failure to comply may void the warranty.
- This treadmill is intended for in-home use only. Do not use this treadmill in any commercial, rental, school or institutional setting. Failure to comply will void the warranty.
- Do not remove the console covers unless instructed by Customer Tech Support. Service should only be done by an authorized service technician

It is essential that your treadmill is used only indoors, in a climate controlled room. If your treadmill has been exposed to colder temperatures or high moisture climates, it is strongly recommended that the treadmill is warmed up to room temperature before first time use. Failure to do so may cause premature electronic failure.

WARNING

This product contains chemicals known to the State of California to cause cancer and birth defects or other reproductive harm.



GROUNDING INSTRUCTIONS

This product must be grounded. If a treadmill should malfunction or breakdown, grounding provides a path of least resistance for electrical current to reduce the risk of electrical shock. This product is equipped with a cord having an equipment-grounding conductor and a grounding plug. The plug must be plugged into an appropriate outlet that is properly installed and grounded in accordance with local codes and ordinances.

DANGER

Improper connection of the equipment-grounding conductor can result in a risk of electric shock. Check with a qualified electrician or serviceman if you are in doubt as to whether the product is properly grounded. Do not modify the plug provided with the product. If it will not fit the outlet, have a proper outlet installed by a qualified electrician.

This product is for use on a nominal 110-120 Volt circuit and has a grounding plug that looks like the plug in the illustration. Make sure that the product is connected to an outlet having the same configuration as the plug. No adapter should be used with this product.

This product must be used on a dedicated circuit. To determine if you are on a dedicated circuit, shut off the power to that circuit and observe if any other devices lose power. If so, move devices to a different circuit. Note: There are usually multiple outlets on one circuit. This treadmill should be used with a minimum 15-amp circuit.

3-POLE
GROUNDED
OUTLET

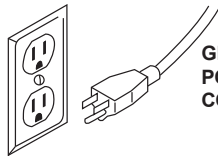

GROUNDED
POWER
CORD

WARNING

Connect this exercise product to a properly grounded outlet only.

Never operate product with a damaged cord or plug even if it is working properly. Never operate any product if it appears damaged, or has been immersed in water. Contact Customer Tech Support for replacement or repair.

ASSEMBLY



WARNING

There are several areas during the assembly process that special attention must be paid. It is very important to follow the assembly instructions correctly and to make sure all parts are firmly tightened. If the assembly instructions are not followed correctly, the treadmill could have parts that are not tightened and will seem loose and may cause irritating noises. To prevent damage to the treadmill, the assembly instructions must be reviewed and corrective actions should be taken.

Before proceeding, find your treadmill's serial number located on a white barcode sticker near the on/off power switch and power cord and enter it in the space provided below.

ENTER YOUR SERIAL NUMBER AND MODEL NAME IN THE BOXES BELOW:

SERIAL NUMBER:

TM

MODEL NAME: **AFG SPORT 2.7AT TREADMILL**

SERIAL NUMBER LOCATION

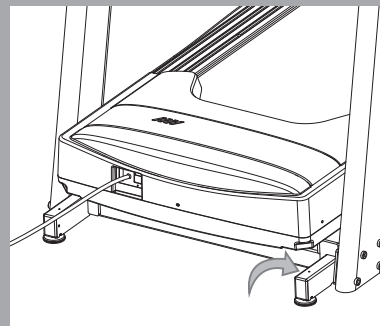

» Refer to the SERIAL NUMBER and MODEL NAME when calling for service.

CONSOLE DISPLAY AND CONTROLS

SPEAKERS

CONSOLE

WATER BOTTLE HOLDER

SUPPORT BAR

ON/OFF SWITCH

POWER CORD

HEART RATE GRIP BARS

CAUTION	ATTENTION	PRECAUCIÓN
KEEP HANDS AND FEET AWAY FROM THIS AREA. HIGH-PRESSURE SHOCKS COULD CAUSE BODILY INJURY.	GARDEZ LES MAINS ET LES PIEDS LOIN DE CETTE RÉGION. LES HAUTES-PRESSIONS À HAUTE PRESION PEUVENT CAUSER DES BLESSURES.	MANTENGAS LAS MANOS Y LOS PIES LEJOS DE ESTA ÁREA. LOS AMORTIGUADORES DE ALTA PRESIÓN PODRÍAN CAUSAR LESIONES.



TRANSPORT WHEEL

FOOT LOCK LATCH (UNDERNEATH DECK)

CONSOLE FAN

READING RACK

HANDLEBARS

SAFETY KEY PLACEMENT

CAUTION RISK OF INJURY TO PERSONS.
ATTACH SAFETY KEY CAP TO CLOTHING BEFORE STARTING. TO AVOID INJURY STRAY TO THE DECK AND DRIVING CONTROL TROUBLE. READ AND FOLLOW ALL INSTRUCTIONS BEFORE OPERATING. KEEP CHILDREN AWAY FROM THE RUNNING BELT. SAFETY KEY MUST NOT BE USED AND STAY OUT OF REACH OF CHILDREN. CONSULT A PROFESSIONAL BEFORE LEAVING THE CONSOLE. DO NOT EXERCISE IF YOU FEEL PAIN. PAIN MAY BE A SIGN OF INJURY. KEEP BODY AND CLOTHING FREE AND CLEAR OF ALL MOVING PARTS FOR CONSUMER USE ONLY.

ATTENTION RISK OF BLESSURES.
ATTACHER LA PÈCE DE LA CLÉ DE SÉCURITÉ AUX VÊTEMENTS AVANT DE COMMENCER. POUR ÉVITER ACCIDENTS PERSONNELS OU DE PROBLÈMES DE FONCTIONNEMENT, LIRE ET SUIVRE TOUTES LES INSTRUCTIONS. NE PAS LAISSER CET COMPLÉMENT À LA PORTÉE DES ENFANTS. LA CLÉ DE SÉCURITÉ DOIT ÊTRE EN TOUTES SAISONS À L'ÉLOIGNEMENT DES ENFANTS. CONSULTER UN MÉDECIN AVANT DE COMMENCER SI VOUS SENTEZ LA DOULEUR. L'APPARITION D'UNE DOULEUR PEUT ÊTRE UN SYMPTÔME D'UNE BLESSURE. GARDER LE CORPS ET LES VÊTEMENTS LIBRES DE TOUT MOUVEMENT, POUR ÉVITER LES BLESSURES.

PRECAUCIÓN EL RIESGO DE UNA LESIÓN PERSONAL.
SUJETE LA LLAVE DE SEGURIDAD A SU ROPA ANTES DE COMENZAR. PARA EVITAR ACCIDENTES PERSONALES O DE PROBLEMAS DE FUNCIONAMIENTO, LEA CUIDADOSAMENTE EL MANUAL DE USUARIO Y SIGA TODAS LAS INSTRUCCIONES. LA LLAVE DE SEGURIDAD DEBE ESTAR SIEMPRE FUERA DEL ALCANCE DE LOS NIÑOS. ANTES DE COMENZAR, CONSULTE A UN MÉDICO SI SIENTE DOLOR. EL DOLOR PUEDE SER UN SÍNTOMA DE UNA LESIÓN. MANTÉNGASE LIBRE Y SIN VESTIMENTAS EN CONTACTO CON PARTES EN MOVIMIENTO PARA EVITAR LESIONES.

CONSOLE MAST

MOTOR COVER

RUNNING BELT / DECK

REAR ROLLER TENSION / ADJUSTMENT BOLTS

CAUTION	AVERTISSEMENT	PRECAUCIÓN
KEEP HANDS AND FEET AWAY FROM THIS AREA.	GARDEZ LES MAINS ET LES PIEDS LOIN DE CETTE RÉGION.	MANTENGAS LAS MANOS Y LOS PIES LEJOS DE ESTA ÁREA.

SIDE RAIL



TOOLS REQUIRED:

- 6 mm T-Wrench (included)
- 6 mm L-Wrench (included)
- 4 mm L-Wrench (included)
- Phillips Screwdriver (not included)

PARTS INCLUDED:

- 2 Console Masts
- 1 Console Assembly
- 2 Console Pockets
- 1 Support Bar
- 1 Hardware Kit
- 1 Safety Key
- 1 Power Cord
- 1 Audio Adapter Cable
- 1 Bottle of Silicone Lubricant
(for 2 applications)



NEED HELP?

If you have questions or if there are any missing parts, contact Customer Tech Support. Contact information is located on the back cover of this manual.

PRE ASSEMBLY

UNPACKING

Place the treadmill carton on a level flat surface. It is recommended that you place a protective covering on your floor. Take CAUTION when handling and transporting this unit. Never open box when it is on its side. Once the banding straps have been removed, do not lift or transport this unit unless it is fully assembled and in the upright folded position, with the lock latch secure. Unpack and assemble the unit where it will be used. The enclosed treadmill is equipped with high-pressure shocks and may spring open if mishandled. Never grab hold of any portion of the incline frame and attempt to lift or move the treadmill.

WARNING

- DO NOT ATTEMPT TO LIFT THE TREADMILL! Do not move or lift treadmill from packaging until specified to do so in the assembly instructions. You may remove the plastic wrap from console masts.
- FAILURE TO FOLLOW THESE INSTRUCTIONS COULD RESULT IN INJURY!

IMPORTANT NOTES

- During each assembly step, ensure that ALL nuts and bolts are in place and partially threaded. It is recommended you complete the full assembly of your unit before completely tightening any ONE bolt.
- Several parts have been pre-lubricated to aid in assembly and usage. Please do not wipe this off. If you have difficulty, a light application of lithium bike grease is recommended.



ASSEMBLY STEP 1

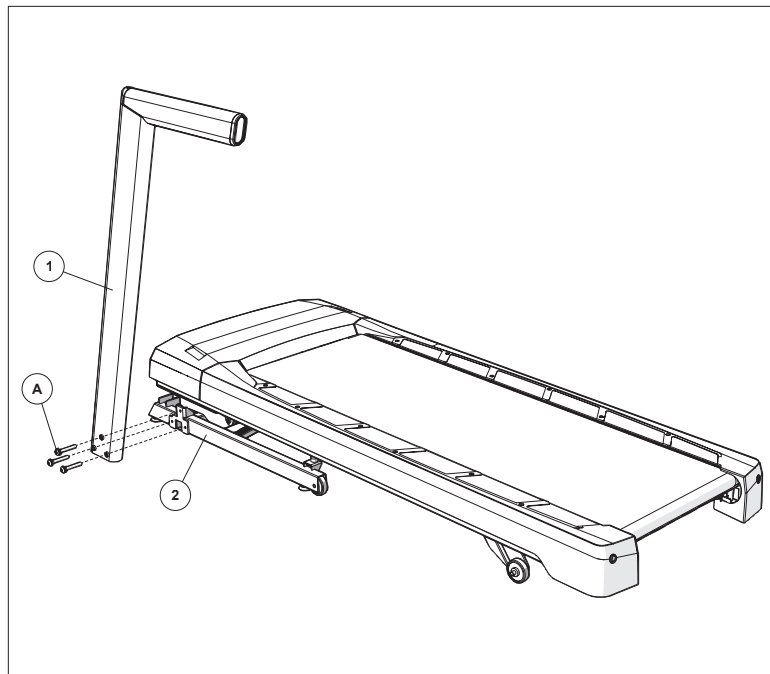

HARDWARE FOR STEP 1			
PART	TYPE	DESCRIPTION	QTY
A	HEX SOCKET BOLT	M8X1.25PX60L	3

- A Cut the yellow banding straps and lift the running deck upward to remove all contents from underneath the running deck.
- B Open **HARDWARE FOR STEP 1**.
- C Attach **LEFT CONSOLE MAST (1)** to **MAIN FRAME (2)** using **3 BOLTS (A)**.

ASSEMBLY STEP 2



HARDWARE FOR STEP 2			
PART	TYPE	DESCRIPTION	QTY
A	HEX SOCKET BOLT	M8X1.25PX60L	3



- A Pull the **CONSOLE CABLE (3)** away from the treadmill base frame. Connect the **CONSOLE CABLE (3)** from the **MAIN FRAME (2)** to the **CONSOLE CABLE (3)** in the bottom of the **RIGHT CONSOLE MAST (4)**. The other end of the **CONSOLE CABLE** should be located at the top of the mast.
- B Open **HARDWARE FOR STEP 2**.
- C Attach **RIGHT CONSOLE MAST (4)** to **MAIN FRAME (2)** using **3 BOLTS (A)**.

NOTE: Be careful not to pinch the console cable while attaching the right console mast.

ASSEMBLY STEP 3

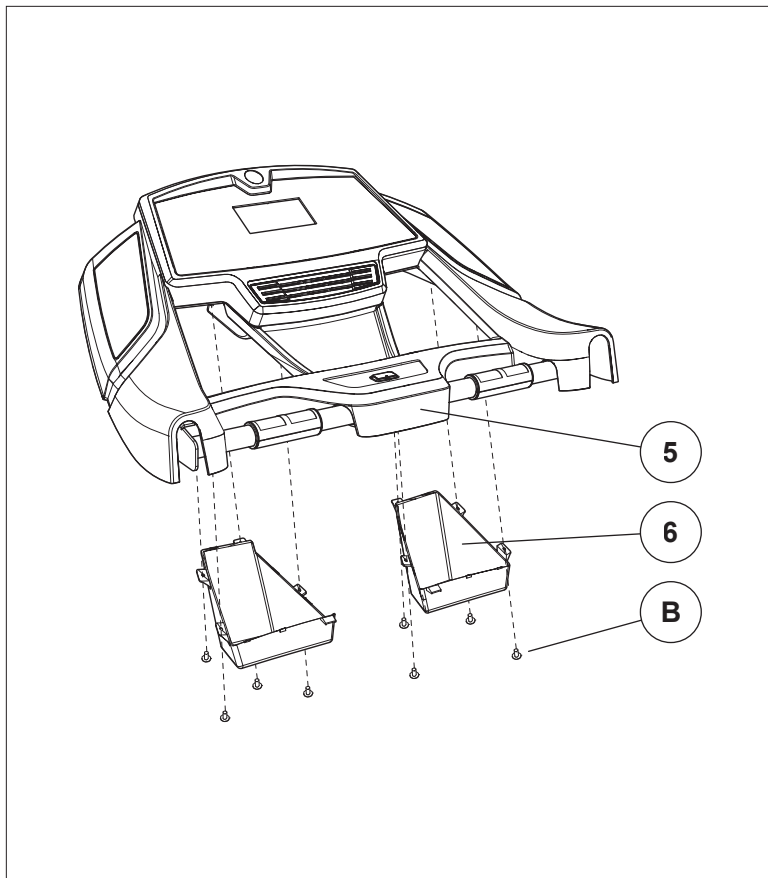

HARDWARE FOR STEP 3			
PART	TYPE	DESCRIPTION	QTY
B	SCREW	4X10L	10

- A Open **HARDWARE FOR STEP 3**.
- B Turn **CONSOLE (5)** over and align **CONSOLE POCKETS (6)** with screw holes.

NOTE: Before securing the pockets, ensure the snap tabs are outside the pocket recess.

- C Attach **CONSOLE POCKETS (6)** to **CONSOLE (5)** using 10 **SCREWS (B)**.

NOTE: Gently loosen the screws if necessary after assembly to snap them into place and avoid breaking the tabs.

ASSEMBLY STEP 4

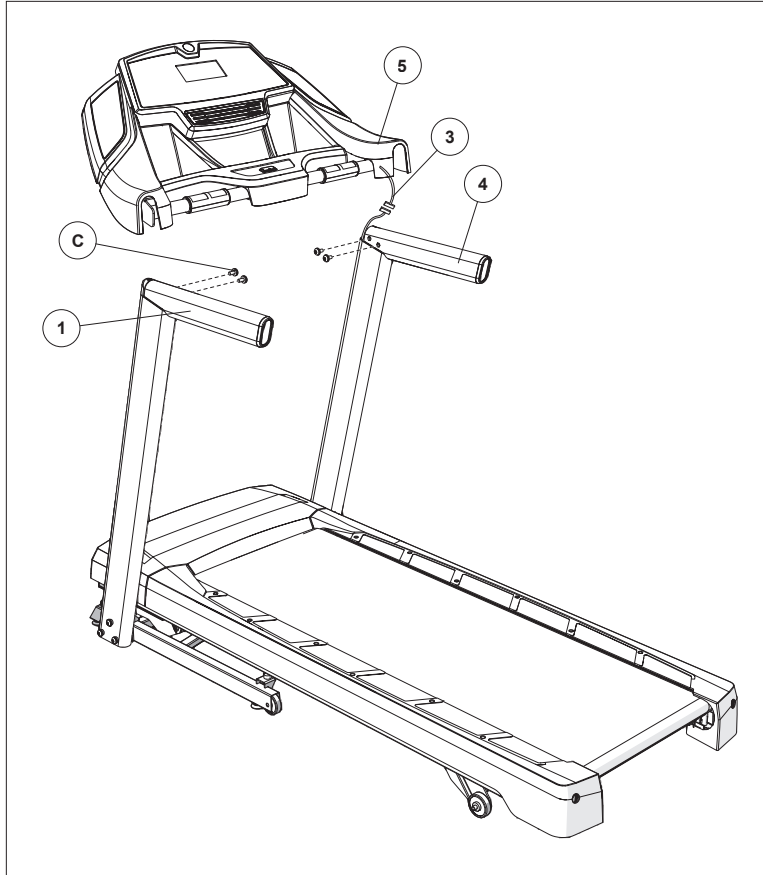

HARDWARE FOR STEP 4			
PART	TYPE	DESCRIPTION	QTY
C	HEX SOCKET BOLT	M8X1.25PX20L	4



- A Open **HARDWARE FOR STEP 4**.
- B Gently place **CONSOLE (5)** on top of **CONSOLE MASTS (1 & 4)**.

NOTE: Be careful not to pinch the console cables while attaching the console.

- C Connect the **CONSOLE CABLES (3)** and ensure cables are tucked inside the **CONSOLE (5)**.
- D Connect the **CONSOLE (5)** to the right **CONSOLE MAST (4)** using 2 **BOLTS (C)**.
- E Repeat STEP D on left side.

ASSEMBLY STEP 5

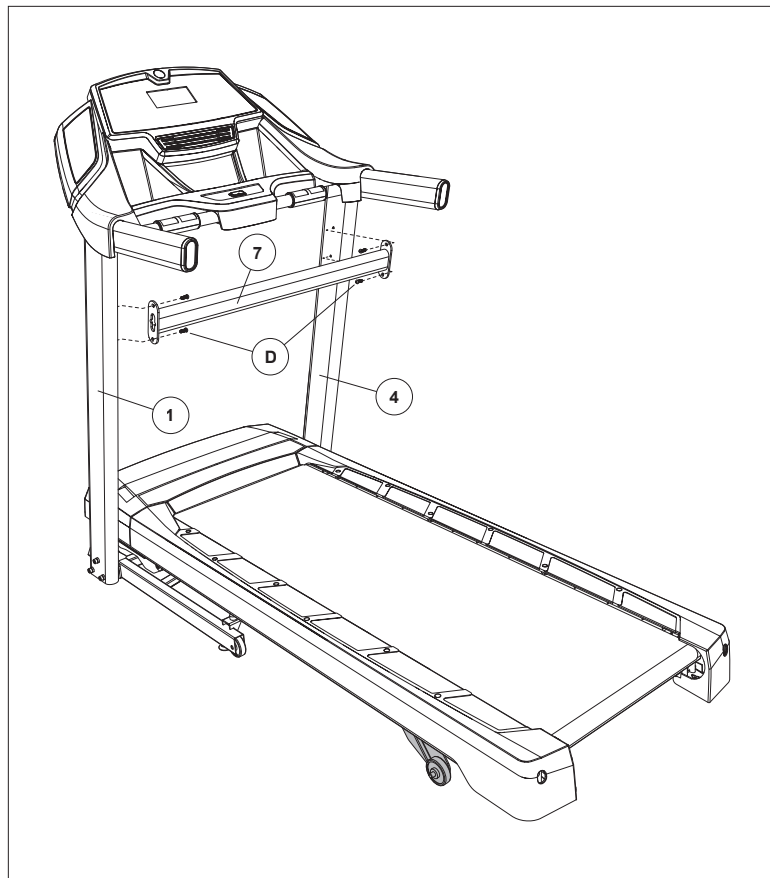

HARDWARE FOR STEP 5			
PART	TYPE	DESCRIPTION	QTY
D	BUTTON HEAD BOLT	M6X1.0PX15L	4

- A Open **HARDWARE FOR STEP 5**.
- B Align **SUPPORT BAR (7)** on top of **CONSOLE MASTS (1 & 4)**.
- C Attach the **SUPPORT BAR (7)** to the **CONSOLE MASTS (1 & 4)** using 4 **BOLTS (D)**.

ASSEMBLY COMPLETE!

Before the first use, lubricate the treadmill deck by following the instructions in the **MAINTENANCE** section in the **TREADMILL GUIDE**.



TREADMILL OPERATION



This section explains how to use your treadmill's console and programming. The BASIC OPERATION section in the TREADMILL GUIDE has instructions for the following:

- LOCATION OF THE TREADMILL
- USING THE SAFETY KEY
- FOLDING THE TREADMILL
- MOVING THE TREADMILL
- LEVELING THE TREADMILL
- TENSIONING THE RUNNING BELT
- CENTERING THE RUNNING BELT
- USING THE HEART RATE FUNCTION

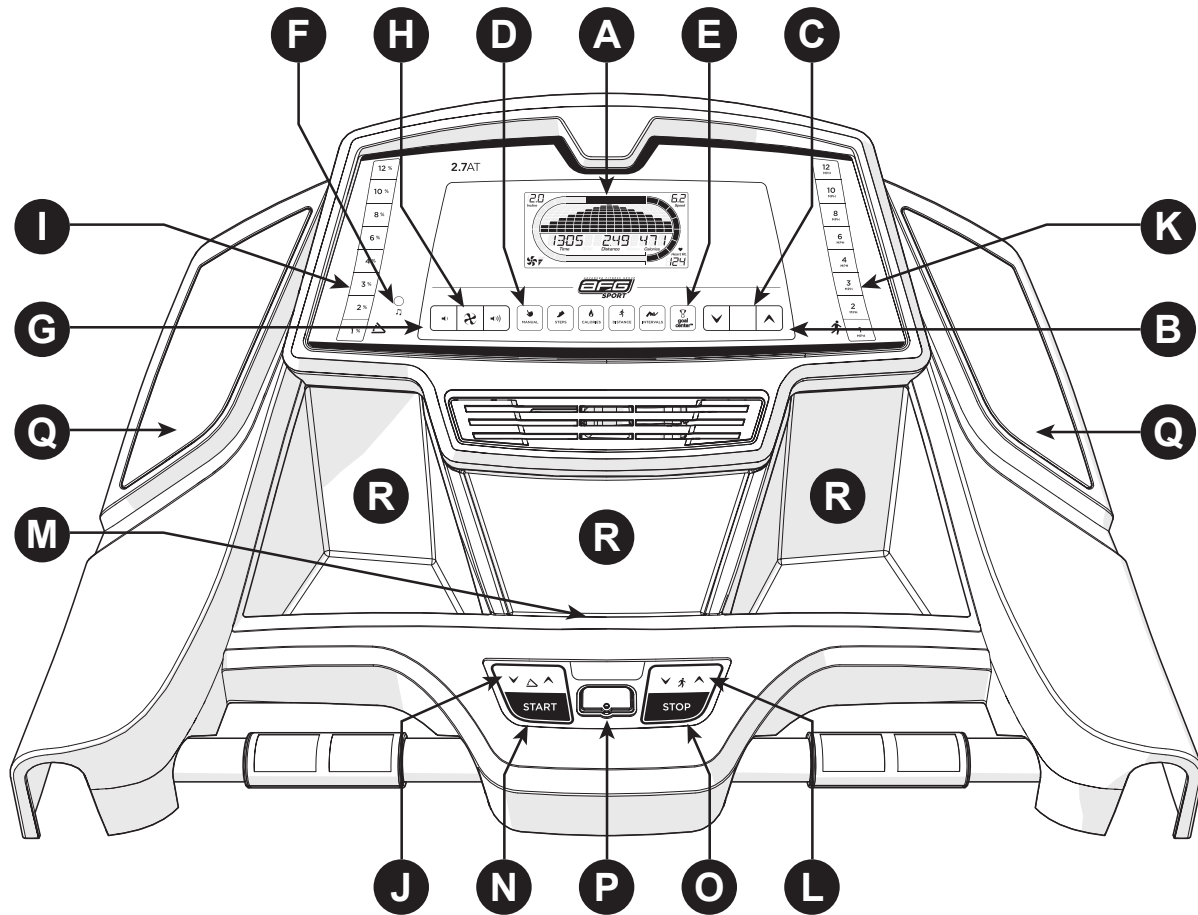

CONSOLE OPERATION

Note: There is a thin protective sheet of clear plastic on the overlay of the console that should be removed before use.



- A) **LCD DISPLAY WINDOW:** time, distance, speed, calories, incline and heart rate.
- B) **PROGRAMMING ∇/\blacktriangle KEYS:** Used to cycle through programs and user setup.
- C) **ENTER:** used to confirm selection.
- D) **PROGRAM KEYS:** press to select workout.
- E) **GOAL CENTER:** press to set or view your goal. See page 22 for more information.
- F) **AUDIO IN JACK:** plug your media player into the console using the included audio adaptor cable.
- G) **VOLUME:** used to adjust volume up or down.
- H) **FAN KEY:** press to turn fan on, off, or adjust the setting.
- I) **INCLINE QUICK KEYS:** used to reach desired incline quickly.
- J) **INCLINE ∇/\blacktriangle KEYS:** used to adjust incline level.
- K) **SPEED QUICK KEYS:** used to reach desired speed quickly.
- L) **SPEED ∇/\blacktriangle KEYS:** used to adjust speed level.
- M) **READING RACK:** holds reading material.
- N) **START / PAUSE:** used to start workout, pause workout, and restart after pause.
- O) **STOP / HOLD TO RESET:** used to stop machine and also will reset machine when held down.
- P) **SAFETY KEY:** enables treadmill when safety key is inserted.
- Q) **SPEAKERS:** plays music through speakers when connected to your media player.
- R) **STORAGE POCKETS:** holds personal items, e.g. water bottle, brought with you.

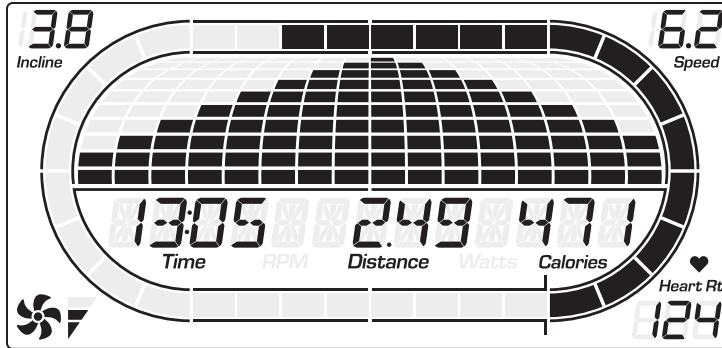

DISPLAY WINDOW

- **TIME:** Shown as minutes : seconds. View the time remaining or the time elapsed in your workout.
- **DISTANCE:** Shown as miles. Indicates distance traveled or distance remaining during your workout.
- **CALORIES:** Total calories burned or remaining for your workout.
- **INCLINE:** Shown as percent. Indicates the incline level of the running surface.
- **SPEED:** Shown as MPH. Indicates how fast the belt is moving.
- **HEART RATE:** Shown as BPM (beats per minute). Used to monitor your heart rate (displayed when contact is made with both pulse grips).
- **PROGRAM PROFILES:** Represents the profile of the program being used (speed during speed based programs and incline during incline based programs).
- **FAN:** Indicates fan setting (low, medium, high).
- **TRACK:** Follows progress around a simulated track. Segments light up with every 12.5 meters completed. One lap around the track is 400 meters (1/4 mile).

GETTING STARTED

- 1) Check to make sure no objects are placed on the belt that will hinder the movement of the treadmill.
- 2) Plug in the power cord and turn the treadmill ON.
- 3) Stand on the side rails of the treadmill.
- 4) Attach the safety key clip to part of your clothing making sure that it is secure and will not become detached during operation.
- 5) Insert the safety key into the safety keyhole in the console.
- 6) Select User 1, User 2, or Guest using ▼▲ and press ENTER.
- 7) Set User Weight using ▼▲ and press ENTER.
- 8) You have two options to start your workout:

A) QUICK START UP

Simply press the START key to begin working out.
Time, distance, and calories will all count up from zero. OR...

B) SELECT A WORKOUT

- 1) Press desired WORKOUT BUTTON and press ENTER.
- 2) Select workout goal level or program using ▼▲ and press ENTER.
- 3) Set workout program information using ▼▲ (see program information for necessary settings) and press ENTER after each selection.
- 4) Press START to begin workout.

NOTE: You can adjust the speed and incline during your workout.



FINISHING YOUR WORKOUT

When your workout is complete, the console will display “workout complete” and beep. Your workout information will stay displayed on the console for 30 seconds and then reset.

TO RESET THE CONSOLE

Hold STOP key for 3 seconds.

TO CLEAR CURRENT SELECTION

To clear the current program selection or screen, hold the stop button for 3 seconds.

PROGRAM INFORMATION



MANUAL: Adjust your speed and incline manually during your workout. User sets time, starting speed and incline.



STEPS: Promotes healthy activity with 10 step-based workouts calculated using average stride length. Choose from 1000, 2000, 3000, 4000, 5000, 6000, 7000, 8000, 9000, and 10,000 step workouts. User sets starting speed and incline.



CALORIES: Set goals for burning calories with six workouts. Choose from 100, 200, 300, 400, 500, and 600 calorie burn workouts. User sets starting speed and incline. Calories burned are calculated using weight input by user with the speed and incline of workout.



DISTANCE: Push yourself and go further during your workout with 10 distance workouts. Choose from 1 mile, 2 miles, 5k, 5 miles, 10k, 8 miles, 15k, 10 miles, 20k, and half marathon goals. User sets starting speed and incline.



INTERVALS: An effective fat-burning workout that helps you get improve your fitness level. Choose from Speed Intervals, Peak Intervals, and Endurance Intervals workouts. User sets time and starting level.

SPEED INTERVALS (10 LEVELS)

Speed changes and segments repeat 90 seconds and 30 seconds

Segment	Warm Up		1	2	Cool Down	
Time	4:00 Mins		90 sec	30 sec	4:00 Mins	
Level 1	1.0	1.5	2.0	4.0	1.5	1.0
Level 2	1.0	1.5	2.0	4.5	1.5	1.0
Level 3	1.3	1.9	2.5	5.0	1.9	1.3
Level 4	1.3	1.9	2.5	5.5	1.9	1.3
Level 5	1.5	2.3	3.0	6.0	2.3	1.5
Level 6	1.5	2.3	3.0	6.5	2.3	1.5
Level 7	1.8	2.6	3.5	7.0	2.6	1.8
Level 8	1.8	2.6	3.5	7.5	2.6	1.8
Level 9	2.0	3.0	4.0	8.0	3.0	2.0
Level 10	2.0	3.0	4.0	8.5	3.0	2.0

ENDURANCE INTERVALS (12 LEVELS) - SPEED ONLY

Segment	Warm Up		1	2	3	4	5	6	7	8	Cool Down		
Time	4:00 Mins		Each segment is 30 Seconds and repeats									4:00 Mins	
Level 1	1.0	1.5	2.0	2.5	3.0	3.5	4.0	3.5	3.0	2.5	2.3	1.5	
Level 2	1.3	1.9	2.5	3.0	3.5	4.0	4.5	4.0	3.5	3.0	2.6	1.8	
Level 3	1.5	2.3	3.0	3.5	4.0	4.5	5.0	4.5	4.0	3.5	3.0	2.0	
Level 4	1.8	2.6	3.5	4.0	4.5	5.0	5.5	5.0	4.5	4.0	3.4	2.3	
Level 5	2.0	3.0	4.0	4.5	5.0	5.5	6.0	5.5	5.0	4.5	3.8	2.5	
Level 6	2.3	3.4	4.5	5.0	5.5	6.0	6.5	6.0	5.5	5.0	4.1	2.8	
Level 7	2.5	3.8	5.0	5.5	6.0	6.5	7.0	6.5	6.0	5.5	4.5	3.0	
Level 8	2.8	4.1	5.5	6.0	6.5	7.0	7.5	7.0	6.5	6.0	4.9	3.3	
Level 9	3.0	4.5	6.0	6.5	7.0	7.5	8.0	7.5	7.0	6.5	5.3	3.5	
Level 10	3.3	4.9	6.5	7.0	7.5	8.0	8.5	8.0	7.5	7.0	5.6	3.8	
Level 11	3.0	4.5	7.0	7.5	8.0	8.5	9.0	8.5	8.0	7.5	5.3	3.5	
Level 12	3.3	4.9	7.5	8.0	8.5	9.0	9.5	9.0	8.5	8.0	5.6	3.8	

PEAK INTERVALS (10 LEVELS)

Speed and Incline changes, segments repeat 90 seconds and 30 seconds

Segment		Warm Up		1	2	Cool Down	
Time		4:00 Mins		90 sec	30 sec	4:00 Mins	
Level 1	Speed	1.0	1.5	2.0	4.0	1.5	1.0
	Incline	1.0	1.5	0.5	1.5	1.5	0.0
Level 2	Speed	1.0	1.5	2.0	4.5	1.5	1.0
	Incline	1.5	2.5	3.0	6.5	2.5	1.5
Level 3	Speed	1.3	1.9	2.5	5.0	1.9	1.3
	Incline	2.0	3.0	4.0	7.5	3.0	2.0
Level 4	Speed	1.3	1.9	2.5	5.5	1.9	1.3
	Incline	2.0	3.0	4.0	8.0	3.0	2.0
Level 5	Speed	1.5	2.3	3.0	6.0	2.3	1.5
	Incline	2.5	3.5	4.5	8.5	3.5	2.5
Level 6	Speed	1.5	2.3	3.0	6.5	2.3	1.5
	Incline	2.5	3.5	4.5	9.0	3.5	2.5
Level 7	Speed	1.8	2.6	3.5	7.0	2.6	1.8
	Incline	2.5	4.0	5.5	9.5	4.0	3.0
Level 8	Speed	1.8	2.6	3.5	7.5	2.6	1.8
	Incline	3.0	4.0	5.5	9.5	4.0	3.0
Level 9	Speed	2.0	3.0	4.0	8.0	3.0	2.0
	Incline	3.0	4.5	6.0	10.0	5.0	3.0
Level 10	Speed	2.0	3.0	4.0	8.5	3.0	2.0
	Incline	3.0	4.5	6.0	10.0	5.0	3.0



GOAL CENTER™

Research shows that those who create and track their fitness goals, on average, achieve greater success than those who do not. Because your new treadmill is equipped with Advance Fitness Group's exclusive GOAL CENTER Performance Tracker, you've taken an important step towards achieving your fitness goals. GOAL CENTER is innovative new software, integrated into your console, that will allow you to track your fitness goals over time, without the need for paper journals or logs.

GOAL CENTER™ SETUP

- 1) Press and hold the **GOAL CENTER** button for approximately five seconds.
 - 2) Select a time, distance or calorie goal using **▼▲**. Press **ENTER**.
 - 3) Use **▼▲** to select a goal value. Press **ENTER**.
 - 4) Use **▼▲** to select the **NUMBER OF DAYS** to complete the goal.
 - 5) Press **ENTER** again to exit **GOAL CENTER** setup.
- NOTE: These steps can also be used to erase an existing goal and set a new one.

HOW TO SAVE WORKOUT STATS TO GOAL CENTER

At the end of your workout, the console will save your workout data towards your goal.

VIEWING GOAL PROGRESS

At any time during or before a workout, you can view your progress towards your goal by pressing the GOAL CENTER button. The console will scroll the remaining time, distance or calories, depending on the goal you set previously and will also scroll the time remaining to achieve your goal.

USING YOUR MEDIA PLAYER



- 1) Connect the included AUDIO ADAPTOR CABLE to the AUDIO IN JACK on the left of the console and the headphone jack on your media player.
- 2) Use your media player buttons to adjust song settings.
- 3) Remove the AUDIO ADAPTOR CABLE when not in use.



ENERGY SAVER (STANDBY MODE)

This machine has a special feature called Energy Saver™ mode. This mode is NOT automatically activated. When Energy Saver mode is activated, the display will automatically enter standby mode (Energy Saver mode) after 15 minutes of inactivity. This feature saves energy by disabling most power to the machine until a key is pressed on the console. This feature can be turned on or off in the engineering menu.

To enter the engineering menu, press and hold the **▲ INCLINE** key and **▼ SPEED** key for 3-5 seconds. Use the **▼ ▲** keys to navigate through the menu to ENG 3. Press **ENTER** to select. Press **ENTER** to navigate to P2 in the ENG 3 menu. Use **▼ ▲** to select ENRGY SVE ON or OFF. Press and hold **STOP** for 3-5 seconds to exit ENG 3. Press and hold **STOP** again for 3-5 seconds to exit the engineering menu.

LIMITED HOME-USE WARRANTY



WEIGHT CAPACITY = 300 lbs (136 kilograms)



FRAME • LIFETIME

Advanced Fitness Group warrants the frame against defects in workmanship and materials for the lifetime of the original owner, so long as the device remains in the possession of the original owner. (The frame is defined as the welded metal base of the unit and does not include any parts that can be removed.)

DRIVE MOTOR/ELEVATION MOTOR • LIFETIME

Advanced Fitness Group warrants the motor against defects in workmanship and materials for the lifetime of the original owner, so long as the device remains in the possession of the original owner. Labor or installation of motor is not covered under the motor warranty.

ELECTRONICS & PARTS • 1 YEAR

Advanced Fitness Group warrants the electronic components, finish and all original parts for a period of one year from the date of original purchase, so long as the device remains in the possession of the original owner.

LABOR • 1 YEAR

Advanced Fitness Group shall cover the labor cost for the repair of the device for a period of one year from the date of the original purchase, so long as the device remains in the possession of the original owner.

EXCLUSIONS AND LIMITATIONS

Who IS covered:

- The original owner and is not transferable.

What IS covered:

- Repair or replacement of a defective motor, electronic component, or defective part and is the sole remedy of the warranty.

What IS NOT covered:

- Normal wear and tear, improper assembly or maintenance, or installation of parts or accessories not originally intended or compatible with the equipment as sold.
- Damage or failure due to accident, abuse, corrosion, discoloration of paint or plastic, neglect, theft, vandalism, fire, flood, wind, lightning, freezing, or other natural disasters of any kind, power reduction, fluctuation or failure from whatever cause, unusual atmospheric conditions, collision, introduction of foreign objects into the covered unit, or modifications that are unauthorized or not recommended by Advanced Fitness Group.
- Incidental or consequential damages. Advanced Fitness Group is not responsible or liable for indirect, special or consequential damages, economic loss, loss of property, or profits, loss of enjoyment or use, or other consequential damages of whatsoever nature in connection with the purchase, use, repair or



maintenance of the equipment. Advanced Fitness Group does not provide monetary or other compensation for any such repairs or replacement parts costs, including but not limited to gym membership fees, work time lost, diagnostic visits, maintenance visits or transportation.

- Equipment used for commercial purposes or any use other than a single family or Household, unless endorsed by Advanced Fitness Group for coverage.
- Equipment owned or operated outside the US and Canada.
- Delivery, assembly, installation, setup for original or replacement units or labor or other costs associated with removal or replacement of the covered unit.
- Any attempt to repair this equipment creates a risk of injury. Advanced Fitness Group is not responsible or liable for any damage, loss or liability arising from any personal injury incurred during the course of, or as a result of any repair or attempted repair of your fitness equipment by other than an authorized service technician. All repairs attempted by you on your fitness equipment are undertaken AT YOUR OWN RISK and Advanced Fitness Group shall have no liability for any injury to the person or property arising from such repairs.
- If you are out of the manufacturer's warranty but have an extended warranty, refer to your extended warranty contract for contact information regarding requests for extended warranty service or repair.

SERVICE/RETURNS

- In-home service is available within 150 miles of the nearest authorized Service Provider (Mileage beyond 150 miles from an authorized service center is the responsibility of the consumer).
- All returns must be pre-authorized by Advanced Fitness Group.
- Advanced Fitness Groups' obligation under this warranty is limited to replacing or repairing, at Advanced Fitness Groups' option, the same or comparable model.
- Advanced Fitness Group may request defective components be returned to Advanced Fitness Group upon completion of warranty service using a prepaid return shipping label. If you have been advised to return parts and did not receive a label, please contact Customer Tech Support.
- Replacement units, parts and electronic components reconditioned to as-new condition by Advanced Fitness Group or its vendors may sometimes be supplied as warranty replacement and constitute fulfillment of warranty terms.
- This warranty gives you specific legal rights, and your rights may vary from state to state.



CUSTOMER TECH SUPPORT

DO NOT RETURN TO THE RETAILER if you have any problems during assembly or if parts are missing.

For fast and friendly service, please contact one of our trained customer technicians via phone, email or our website.

We want to know if you have a problem and we want to have an opportunity to correct it for you.

NOTE: Please read the TROUBLESHOOTING section in the TREADMILL GUIDE before contacting Customer Tech Support. Additional product information is available on our website.



USA & CANADA:

1-855-396-2524

support@advancedfitnessgroup.com

www.afgfitness.com

Advanced Fitness Group
1600 Landmark Drive,
Cottage Grove WI, 53527