

EXERPEUTIC
THERAPEUTIC FITNESS

Walk To Fit Treadmill

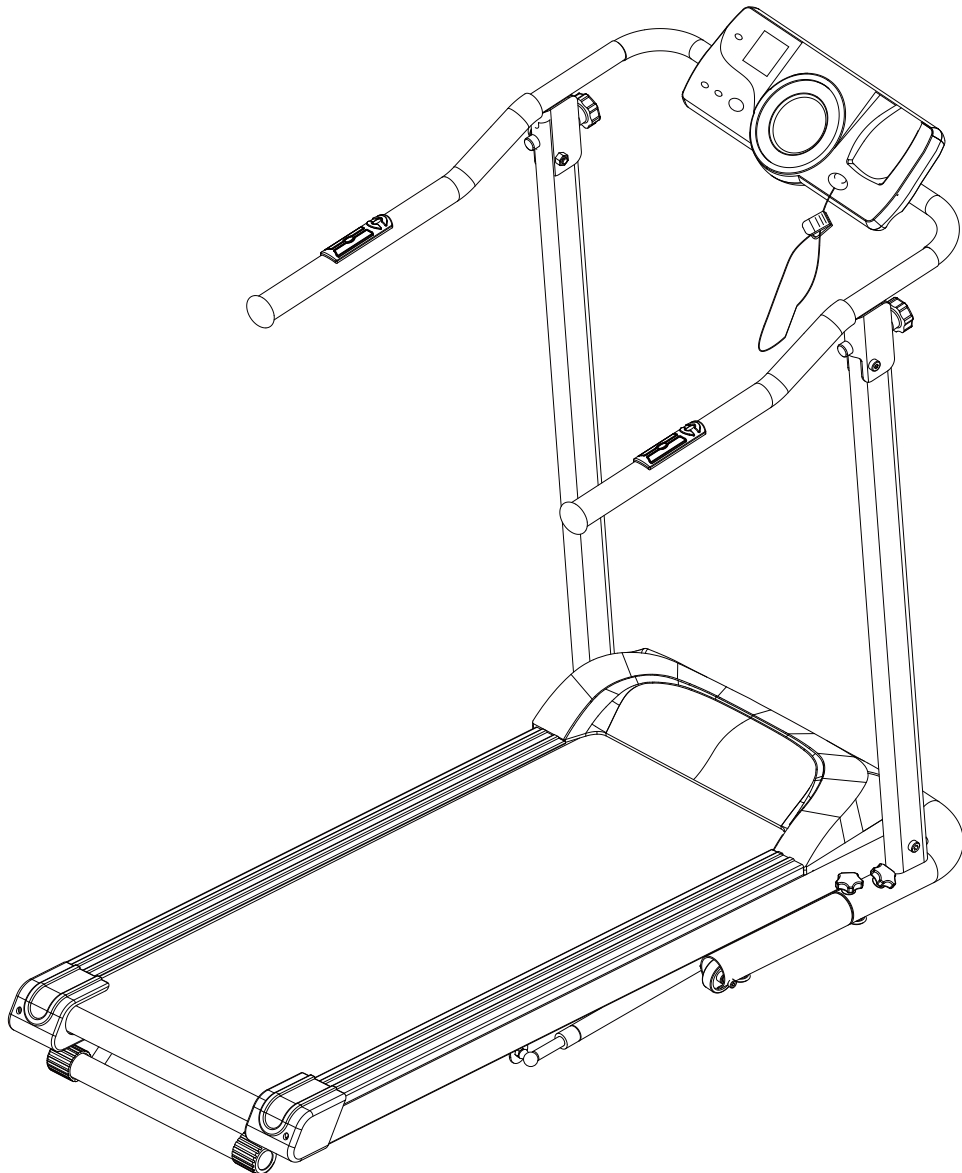

Item#1020

OWNER'S MANUAL

TABLE OF CONTENTS

SERVICE	2
LABEL PLACEMENT	3
PRODUCT SAFETY	4
OVERVIEW DRAWING	8
PARTS LIST	9
COMPUTER KNOBS INCLUDED & TOOL	11
ASSEMBLY	12
COMPUTER	15
STORAGE	18
ADJUSTMENTS	19
LUBRICATION	21
TROUBLE SHOOTING & MAINTENANCE	22
WARM UP	25
WARRANTY	26
FAX FORM	27

SERVICE

IMPORTANT: FOR NORTH AMERICA ONLY

For damaged or defective product, questions, replacement parts or any other service support, please contact our customer service department (8:00 AM - 5:00 PM Pacific Standard Time, Daily) by the below methods:

For Best Service, please Email:

Service@paradigmhw.com

Response Time: 1-2 Business Days

Website:

www.paradigmhw.com

Toll-Free:

1-844-641-7921

Response time may vary.

Please have the following information ready when requesting for service:

Your name

Phone number

Model number

Serial number

Part number

Proof of Purchase

For damaged or defective product please contact our customer service before returning to the store.

Paradigm Health & Wellness, Inc.

1189 Jellick Ave.

City of Industry, CA 91748, USA

LABEL PLACEMENT

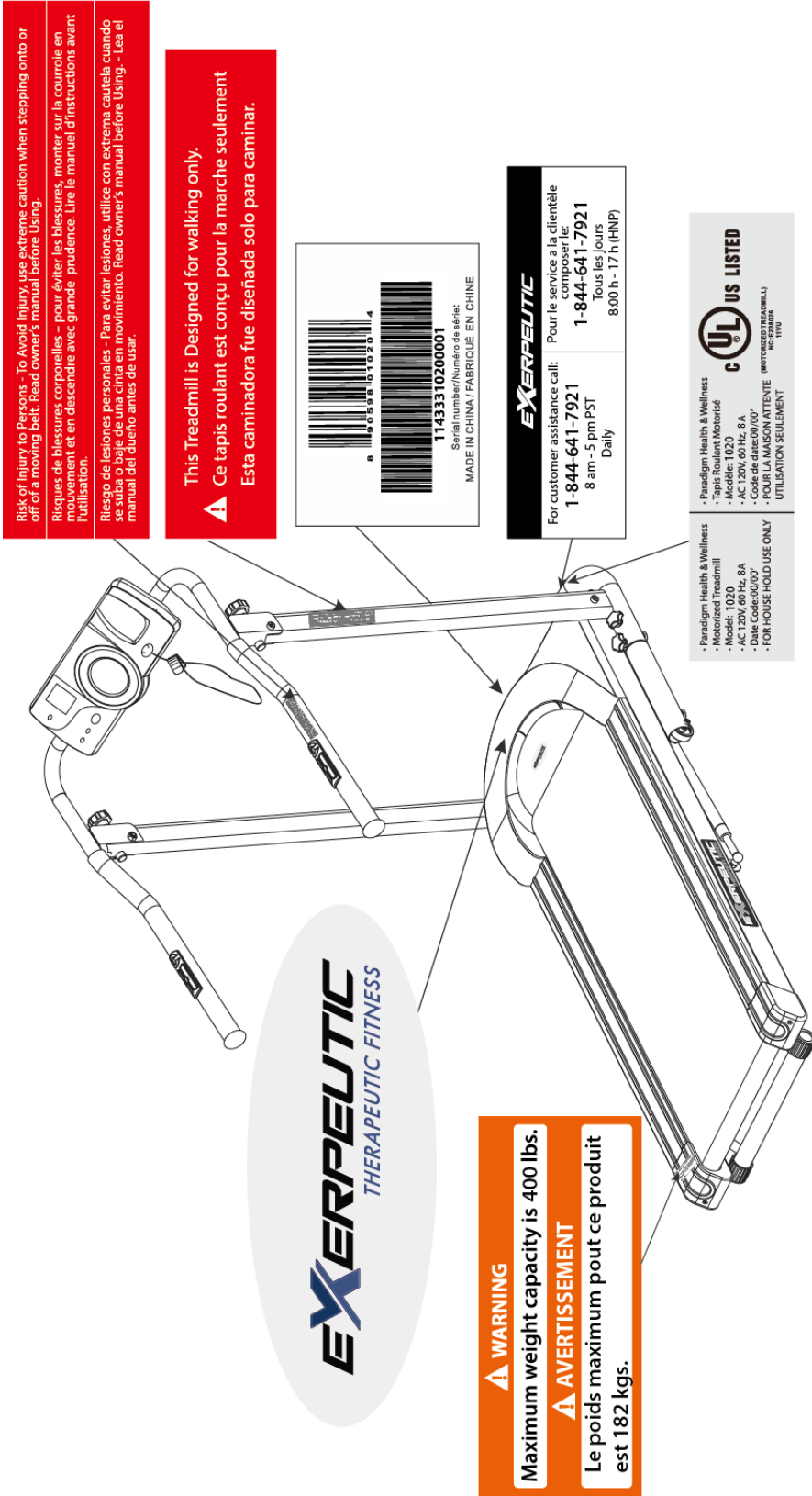

PRODUCT SAFETY

Basic precautions should always be followed, including the following safety instructions when using this treadmill: Read all instructions before using this treadmill.

DANGER: To reduce the risk of electric shock, please read the following:

- Always unplug the treadmill from the electrical outlet immediately after using and before cleaning, assembling, or servicing.

NOTE: Failure to follow these instructions may lead to personal injury and cause damage to the treadmill.

WARNING: To reduce the risk of burns, fire, electric shock or injury to any persons, please read the following:

- Never leave the treadmill unattended when plugged in. Disconnect by turning off the master power switch, and unplugging from outlet when not in use and before putting on or taking off parts.
- Use this appliance only for its intended use as described in this manual. Do not use attachments not recommended by the manufacturer.
- Never operate this treadmill if it has a damaged cord or plug, or if it is not working properly. If it has been dropped or damaged, or been exposed to water, return the appliance to a service center for examination and repair.
- Do not attempt any maintenance or adjustments other than those described in this manual. Should any problems arise, discontinue use and consult an *Authorized Service Representative*.
- Never operate the appliance with the air openings blocked. Keep the air openings free of lint, hair, and the like.
- Do not use the treadmill outdoors.
- Do not pull the treadmill by its power cord or use the cord as a handle.
- Keep children and pets away from the equipment while in use. This machine is designed for adults only. Close supervision is necessary when this treadmill is used by on, near invalids or disabled persons.
- Do not operate where aerosol (spray) products are being used or where oxygen is being administered.
- Keep Dry - do not operate in a wet or moist condition. Save these instructions.

PRODUCT SAFETY

- Do not operate the treadmill near a blanket. Excessive heating can occur and cause fire, electrical shock, or injury to user.
 - Keep electrical cord away from heated surfaces.
 - Never insert any object into any opening.
 - Keep the treadmill on a solid, level surface with the minimum safety area clearance of 2000mm x 1000mm of the treadmill. Be sure the area around the treadmill remains clear during use and has adequate clearance.
 - This treadmill is for household use only.
 - Only **one** person should be on the treadmill while in use.
 - Wear comfortable and suitable clothing when using the treadmill. Do not use the treadmill barefoot, in only socks or in sandals, always wear athletic shoes. Never wear loose clothing because it could run the risk of getting caught in the treadmill.
 - Always hold on to the handrails while using the treadmill.
 - Always make sure the storage latch is in place when folding and moving the treadmill.
 - Do not leave children who are under 12 year-old unsupervised near or on the treadmill.
 - To disconnect, turn all controls to the off position, then remove plug from outlet.
 - This appliance is not intended for use by persons (including children) with reduced physical, sensory or mental capabilities, or lack of experience and knowledge, unless they have been given supervision or instruction concerning use of the appliance by a person responsible for their safety. Children should be supervised to ensure that they do not play with the appliance.
 - Pull up the Safety Tether Key for emergency stop. Reinstall the Safety Tether Key onto the Computer Console. Press the START/STOP button to begin exercise again.
 - **Maximum Weight Capacity is 400 lbs / 182kgs**
 - This treadmill is designed for **WALKING** only.
 - **CAUTION:** Risk of Injury to Persons –To Avoid Injury, use extreme caution when stepping onto or off of a moving belt. Read Instruction Manual Before Using.
- Note: It is the obligation of the owner to review and explain these safety precautions to all users of this treadmill.**

PRODUCT SAFETY

WARNING: Connect the treadmill to a properly grounded outlet only. See grounding instructions.

SAVE THESE INSTRUCTIONS

GROUNDING INSTRUCTIONS

- This product must be grounded. If it should malfunction or break down, grounding provides a path of least resistance for electric current reducing the risk of electric shock. * **This treadmill is equipped with a cord having equipment grounding conductor and a grounding plug. The plug must be plugged into an appropriate outlet that is properly installed and grounded in accordance with all local codes and ordinances.**

DANGER: Improper connection of the treadmill grounding conductor can result in the risk of electric shock. Check with a qualified electrician, if you are in doubt as to whether the product is properly grounded. Do not modify the plug provided with the treadmill. If it will not fit your outlet, have a properly grounded outlet installed by a qualified electrician.

This product is for use on a nominal 120 volt circuit and has a grounding plug that looks like the plug illustrated in sketch A in Figure 1. Make sure that the product is connected to an outlet having the same configuration as the plug. No adapter should be used with this product.

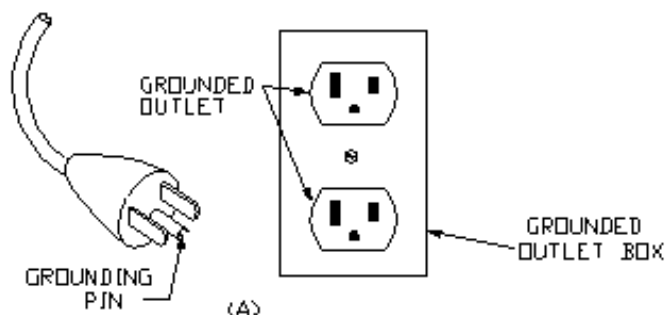

Figure 1

PRODUCT SAFETY

- This unit must be plugged into a nominal 120 volt, which has a grounding.
- Keep hands clear of all moving parts. Never place hands, feet under the treadmill.
- Do not use the treadmill on a carpet that is greater than 1/2 inch in height.
- Before using the treadmill, check that the belt is aligned and centered on the walking deck and all visible fasteners on the treadmill are sufficiently tightened and secure.

WARNING: Before beginning any exercise program consult your physician. This is especially important for the persons who are over 35 years old or who have pre-existing health problems. Read all instructions before using any fitness equipment. We assume no responsibility for personal injury or property damage sustained by or through the use of this product. Do not operate this exercise equipment without properly fitted guards, as the moving parts can present risk of serious injury to young children.

CAUTION: Read all instructions carefully before operating this product. Retain this Owner's Manual for future reference.

OVERVIEW DRAWING

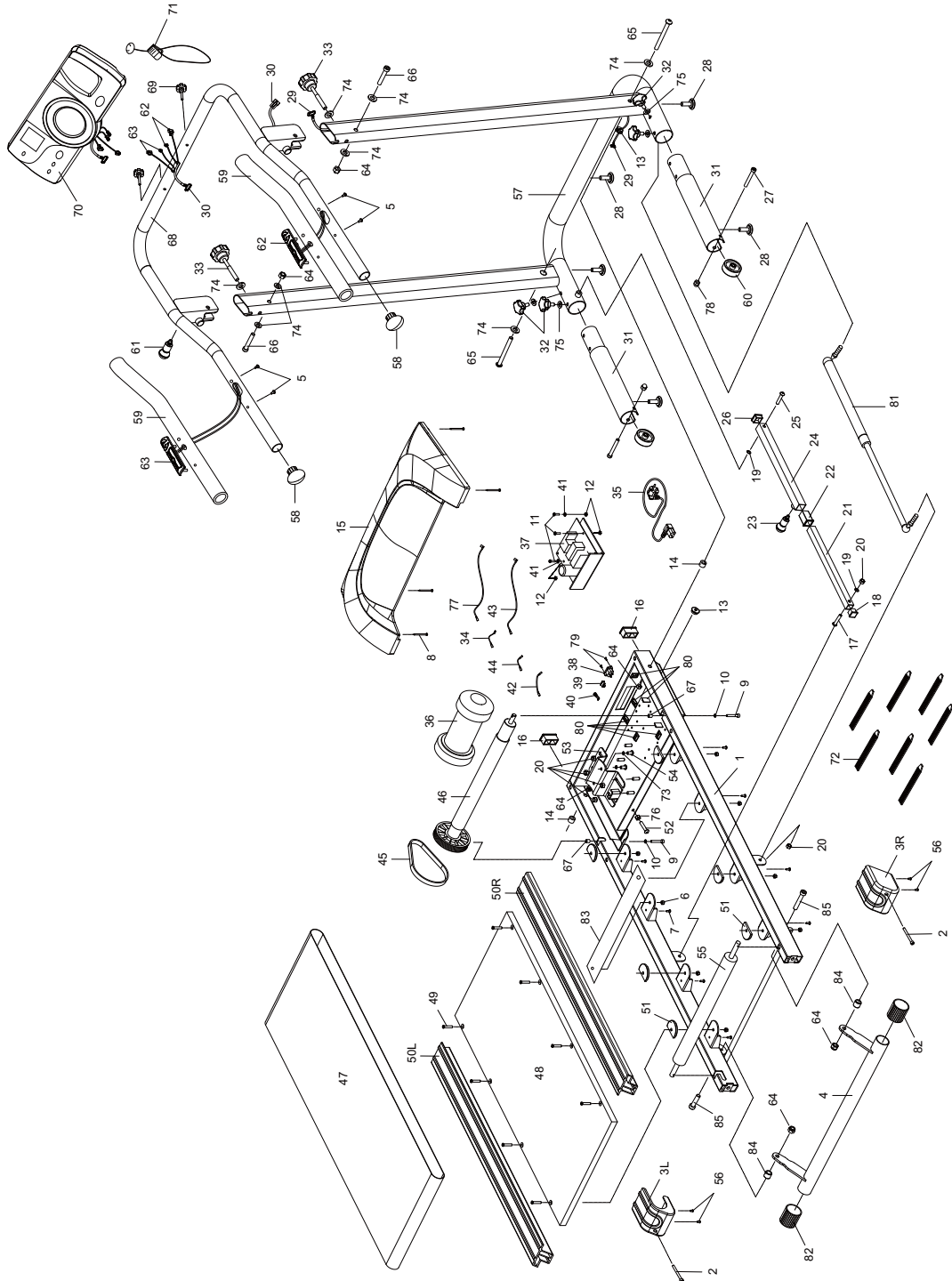

PARTS LIST

Part #	Description	Qty	Part #	Description	Qty
001	Main Frame	1	025	Bolt (M8x40mm)	1
002	Rear Roller Adjustment Bolt (M8x70mm)	2	026	Safety Tube B Square End Cap (□25.4)	1
003R	Rear Right End Cap	1	027	Bolt (M8x60mm)	2
003L	Rear Left End Cap	1	028	Adjustable Leveler (M10xØ28x40)	5
004	Incline Adjuster	1	029	Sensor Cable I (1750mm)	1
005	Self-Tapping Screw (ST3x20mm)	4	030	Sensor Cable II (980mm)	1
006	Nylon Nut (M6)	8	031	Stabilizer Tube (Ø50.8x450)	2
007	Self-Tapping Screw (M4x16mm)	8	032	Stabilizer Knob (M8xØ40xØ10.5x15.5mm)	4
008	Self-Tapping Screw (M4x50mm)	4	033	Handlebar Knob (M10xØ50x108)	2
009	Bolt (M6x40mm)	2	034	Earth Lead (120mm)	1
010	Spring Washer (M6)	2	035	Power Cord	1
011	Bolt (M4x12mm)	3	036	Motor	1
012	Nut (M4)	3	037	Power Control Board (97100-3)	1
013	Wire Cap (Ø6x21x10)	2	038	Power Cord Socket (CH-411)	1
014	Spacer (Ø18xØ10.5x31mm)	2	039	Switch, AC Power (R11-16A)	1
015	Motor Cover	1	040	Fuse Box (R3-9 15A)	1
016	Rectangular End Cap (□25x50)	2	041	Washer (M4)	2
017	Bolt (M8x35mm)	1	042	Wire for Fuse Box (120mm)	1
018	Safety Tube A Square End Cap (□20)	1	043	Wire for Power Control Board (480mm)	1
019	Nylon Washer (M8)	2	044	Wire for Power Switch (80mm)	1
020	Nylon Nut (M8)	6	045	Belt (180J5)	1
021	Safety Tube A (F20x330mm)	1	046	Front Roller (Ø40x599)	1
022	Bushing (F23xF20.3x42)	1	047	Walking Belt (2140x508x1.6)	1
023	Spring Knob (Ø8xØ22x71)	1	048	Walking Deck (557.6x940x18)	1
024	Safety Tube B (F25.4x1.5x340)	1	049	Bolt (M6x33mm)	8

PARTS LIST

Part #	Description	Qty	Part #	Description	Qty
050R	Right Side Rail (79.5x39x895)	1	068	Handlebar (692x793x161)	1
050L	Left Side Rail (79.5x39x895)	1	069	Computer Knob (M5xØ25x55)	2
051	Deck Bumper (48x32x5)	6	070	Computer	1
052	Bolt (M8x45mm)	1	071	Safety Tether Key (SD-7934-1)	1
053	Motor Bracket	1	072	Nylon Bundling Strip	7
054	Bolt (M8x12mm)	2	073	Spring Washer (M8)	2
055	Rear Roller (Ø40x599)	1	074	Washer (M10)	8
056	Screw (M4x8mm)	4	075	Washer (Ø21xØ8.5x1.8t)	4
057	Stabilizer (820.8x283x1091)	1	076	Nut (M8)	1
058	Handlebar End Cap (Ø41xØ28.5x40)	2	077	Wire (400mm)	1
059	Foam Grip (Ø30xØ37x537)	2	078	M8 Nut Cap	2
060	Transport Wheel (Ø8.5xØ50x23)	2	079	Bolt (M3x10mm)	2
061	Short Knob (Ø8xØ20x36)	1	080	Binding Wire Plate 20x20x7	7
062	Hand Pulse Sensor and Speed Button with Wires (1150MM 3P)	1	081	Gas Spring	1
063	Hand Pulse Sensor and Mode / On Off Button with Wires (1150MM 3P)	1	082	Incline Adjuster Cover Ø50	2
064	Nylon Washer (M10)	6	083	Support Board	1
065	Bolt (M10x100mm)	2	084	Spacer Ø16xØ11x15.5mm	2
066	Bolt (M10x50mm)	2	085	Bolt (M10x40mm)	2
067	Spacer (Ø13.5xØ8.5x24mm)	2			

COMPUTER KNOBS INCLUDED & TOOL

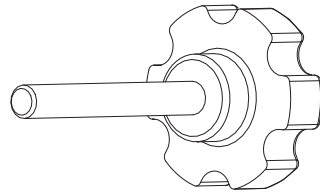

(69) Computer Knob (M5xØ25x55)
2 PCS



Allen Wrench
1 PC

ASSEMBLY

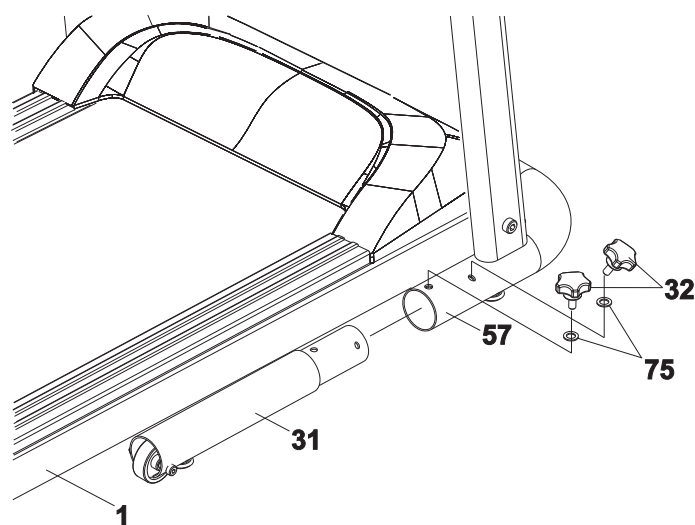

Step 1

Place the treadmill in the upright position and then place one hand on the rear end of Main Frame (1) and use your other hand to pull out the Spring Knob (23). Lower the Main Frame (1) down from the rear of treadmill until the Spring Knob (23) "pops" down into the locked position.

TO PREVENT INJURY PLEASE MAKE SURE YOU HAVE A FIRM HOLD WHEN SETTING DOWN THE DECK.

Remove four Stabilizer Knobs (32) and four $\text{Ø}21 \times \text{Ø}8.5 \times 1.8\text{t}$ Washers (75) from the right and left sides of the Stabilizer (57). Then install both Stabilizer Tubes (31) to the Stabilizer (57) by inserting both Stabilizer Tubes (31) into the Stabilizer (57), using four Stabilizer Knobs (32) and four $\text{Ø}21 \times \text{Ø}8.5 \times 1.8\text{t}$ Washers (75) that were removed.

ASSEMBLY

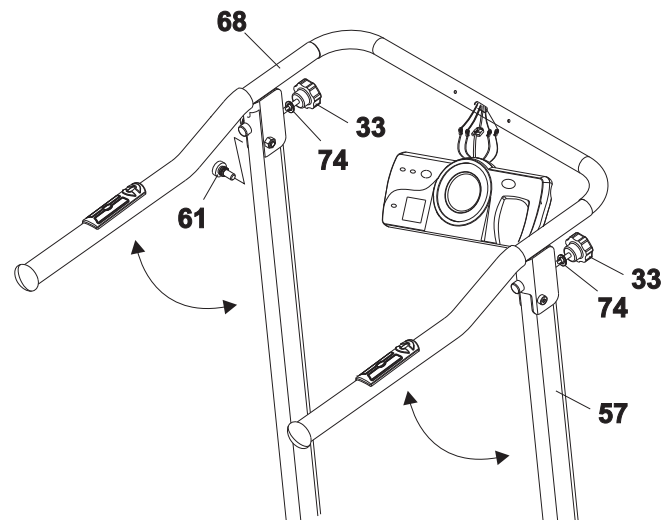

Step 2

Pull the Short Knob (61) and then lift the Handlebar (68) all the way up. Tighten the Handlebar (68) to the Stabilizer (57) with two Handlebar Knobs (33) and two M10 Washers (74).

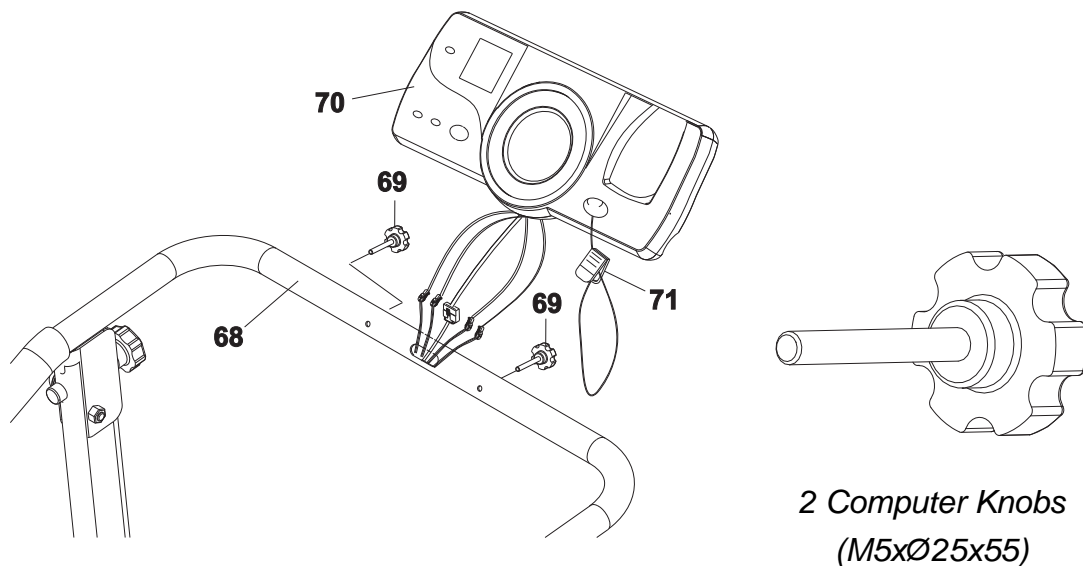

Step 3

Attach the Computer (70) onto the Handlebar (68) with two Computer Knobs (69). Place the Safety Tether Key (71) onto the Computer (70).

ASSEMBLY

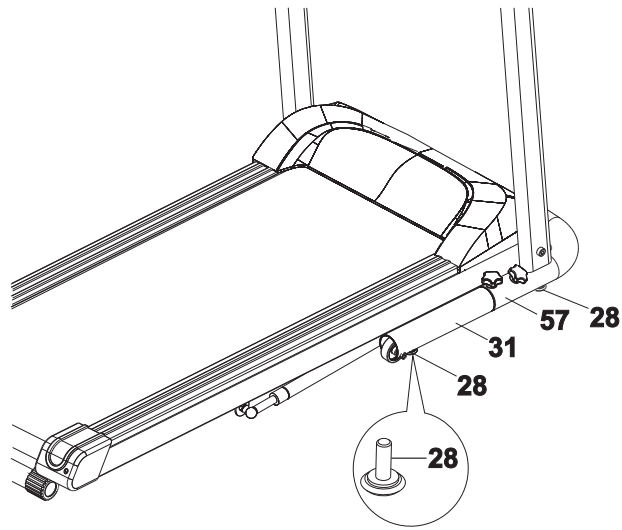

Step 4

There are five Adjustable Levelers (28) on the bottom of both Stabilizer Tubes (31) and Stabilizer (57). Turn the Adjustable Leveler (28) as needed to level the treadmill.

COMPUTER

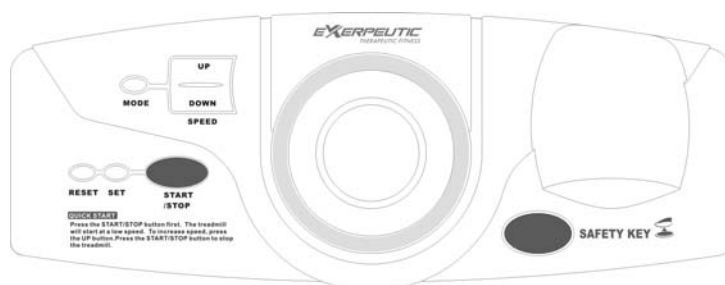

Quick Start:

Flip the Master Power Switch that is located at the front of the treadmill to the ON position. The treadmill will self-test for 2 seconds on startup and then the speed setting will show up after a 2 second long beep. Before beginning a workout session ensure that the Safety Tether Key is properly placed onto the Computer Console and the Safety Clip is securely attached to an article of your clothing. Always begin the treadmill standing on the side rails, not on the belt. In TIME mode you may change the CLOCK setting. To set the time, starting with hours first, press the SET button to change the hours and then press the MODE button, once again press the SET button to change the minutes and press the MODE button to confirm. The computer display will leave set up mode if no buttons are pressed for 6 seconds. After set up is done, the computer will display training mode.

Press the START/STOP button to start exercise. The belt will start moving with an initial speed of 0.4 MPH. The split window of TIME will display in your elapsed workout TIME. The split window of DISTANCE will display your cumulative DISTANCE. The split window of CALORIES will display your total CALORIES burned during your workout. The split window of PULSE will display your current heart rate 4 - 5 seconds after you grip the handlebar sensors with both your hands during exercise. Please hold on to both handlebar sensors for a more precise reading. You may press SPEED UP or SPEED DOWN button on the computer console or right handlebar to increase or decrease the walking speed during exercise. The treadmill's speed range is from 0.4 MPH to 4.0 MPH. The SPEED section will display your current speed. During training, you may press the START/STOP button to stop the treadmill running at any time, press the START/STOP button to start the treadmill running again. You may pull out the safety tether key to stop the treadmill running

Button Functions:

START/STOP: Press the START/STOP button to start or stop the treadmill running.

MODE: Press MODE button to select each function (TIME, DISTANCE, CALORIES, or PULSE) for target pre-setting.

SET: Press SET button to set data values of TIME, DISTANCE, CALORIES, or PULSE for target pre-setting. To set hours and minutes for clock setting in time mode.

COMPUTER

RESET: Press the RESET button to clear data values of TIME, DISTANCE, CALORIES, or PULSE to zero for target pre-setting.

Press and hold the RESET button for 2 seconds, all data values will clear to zero.

SPEED UP: Press the SPEED UP button to increase walking speed.

SPEED DOWN: Press the SPEED DOWN button to decrease walking speed.

Computer Functions:

TIME: Displays your elapsed workout time in minutes and seconds. Press the START/STOP button to start exercise. The walking belt starts moving at speed of 0.4 MPH. You may press the SPEED UP or SPEED DOWN button on the computer console or right handlebar to increase or decrease walking speed during exercise. You may also pre-set target time in STOP mode before training. To set TIME press the MODE button until you see the TIME begin blinking. Press the SET button to change the time, each time you press the SET button TIME should change by 1 minute. The pre-set target time range is from 0:00 to 99:00 minutes. Once you pre-set target time, press the START/STOP button to start exercising. The walking belt starts moving at a speed of 0.4 MPH. You may press the SPEED UP or SPEED DOWN button on the computer console or right handlebar to increase or decrease the walking speed during exercise. TIME starts counting down from pre-set target time to 0:00 per 1 second backward. When the pre-set target time counts down to 0:00, the computer will begin beeping to remind you. The treadmill will stop operation automatically.

SPEED: Displays the current speed from the minimum 0.4 MPH to the maximum 4.0 MPH. You may increase or decrease the speed by pressing the SPEED UP or SPEED DOWN button on the computer console or right handlebar.

DISTANCE: Displays the cumulative distance traveled during your workout. Press the START/STOP button to start exercise. The walking belt starts moving at speed of 0.4 MPH. You may press the SPEED UP or SPEED DOWN button on the computer console or right handlebar to increase or decrease walking speed during exercise. You may also pre-set target distance in STOP mode before training. To set DISTANCE press the MODE button until you see the DISTANCE begin blinking. Press the SET button to set DISTANCE. The pre-set target distance range is from 0.00 to 99.90 miles. Once you pre-set target distance, press START/STOP button to start exercising. The walking belt starts moving at a speed of 0.4 MPH. You may the press SPEED UP or SPEED DOWN button on the computer console or right handlebar to increase or decrease the walking speed during exercise. Distance starts counting down from pre-set target distance to 0.00. When the pre-set target distance counts down to 0.00, the computer will begin beeping to remind you. The treadmill will stop operation automatically.

COMPUTER

CALORIES: Displays the total cumulative calories burned during your workout. Press START/STOP button to start exercising. The walking belt starts moving at speed of 0.4 MPH. You may press the SPEED UP or SPEED DOWN button on the computer console or right handlebar to increase or decrease walking speed during exercise. You may also pre-set target calories in STOP mode before training. To set CALORIES press the MODE button until you see the CALORIES begin blinking. Press the SET button to set CALORIES. The pre-set target calories range is from 0 to 9990 calories. Once you pre-set target calories, press the START/STOP button to start exercising. The walking belt starts moving with the speed at 0.4 MPH. You may press the SPEED UP or SPEED DOWN button on the computer console or right handlebar to increase or decrease the running speed during exercise. Calories start counting down from pre-set target calories to 0. When the pre-set target calories count down to 0, the computer will begin beeping to remind you. The treadmill will stop operation automatically.

PULSE: The split window of PULSE will display your current heart rate 4 – 5 seconds after you grip the handlebar sensors with both your hands during exercise. Please hold on to both handlebar sensors for a more precise reading. To set PULSE press the MODE button until you see the PULSE begin blinking. Press the SET button to change the pulse. The pre-set heart rate range is from 30 to 240 beats per minute. Once you pre-set target heart rate, press the START/STOP button to start exercise. Please hold both two hands on to handlebar grip sensors during exercise. If the heart rate detected greater than the target heart rate, the computer will begin beeping to remind you.

NOTE: If you leave the equipment and it is not operated for over 4 minutes, the computer will display (shows up) the clock (time) and room temperature; that is called sleep mode. In sleep mode, all other functions will turn off. All previous pre-set data and training data are kept and will show up when any button is pressed.

STORAGE

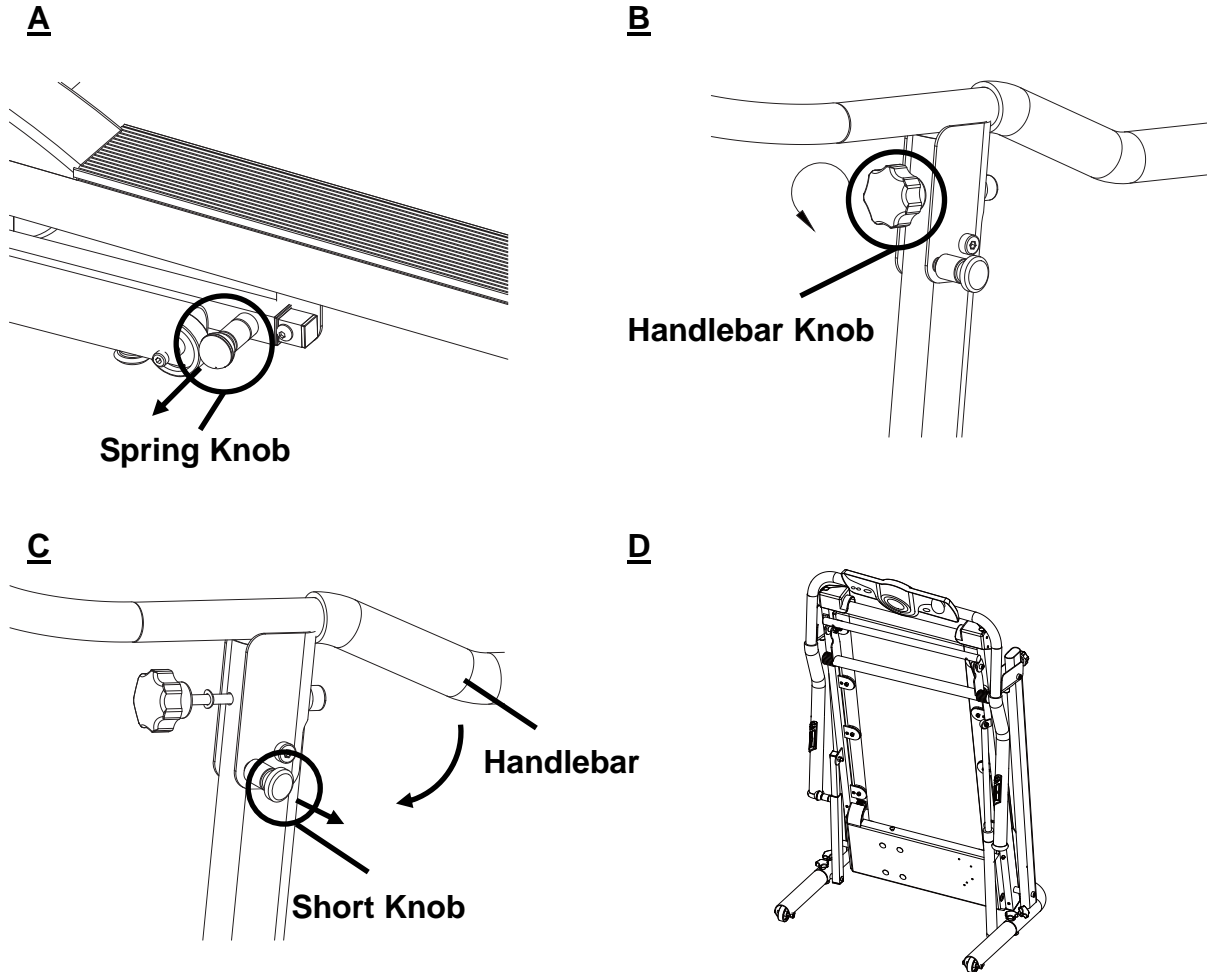

FOLDING THE TREADMILL

For your convenience, the treadmill can be folded up and placed in a storage area.

To fold the treadmill place one hand on the rear end of main frame and use your other hand to pull out the Spring Knob, then lift the main frame up until the Spring Knob "pops" down into the locked position as shown in figure A.

Release both Handlebar Knobs as shown in figure B.

Pull out the Short Knob and then push the Handlebar all the way down.

Insert both Handlebar Knobs back to the Stabilizer as shown in figure C.

The figure D shows the treadmill in the folded position. Now the treadmill is ready to be stored.

IMPORTANT: TO PREVENT INJURY PLEASE MAKE SURE YOU HAVE A FIRM HOLD WHEN LIFTING UP OR SETTING DOWN THE DECK.

ADJUSTMENTS

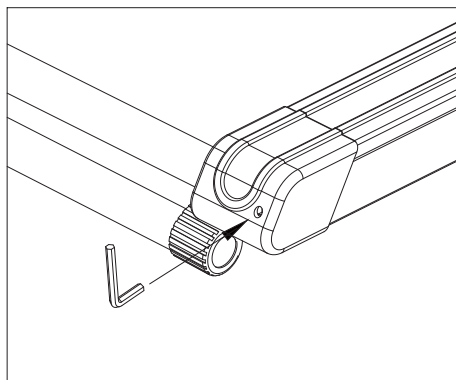

Belt Adjustment:

The belt is adjusted at the factory; it may come loose during transportation and/or from use. After prolonged use of the treadmill, the belt will stretch out. If the belt is shifting to the left, turn on the main power switch of treadmill and let the belt run at the speed of 1-1.5 MPH. Using the Allen wrench provided, turn the left rear roller adjustment bolt 1/4 turn in the clockwise direction. You should see the belt start to correct itself by moving back toward the center. Repeat the above procedure until the belt is properly centered. If the belt is shifting to the right, turn on the main power switch of treadmill and let the belt run at the speed of 1-1.5 MPH. Using the Allen wrench provided, turn the right rear roller adjustment bolt 1/4 turn in the clockwise direction. You should see the belt start to correct itself by moving back toward the center. Repeat the above procedure until the belt is properly centered. If the belt is slipping during use, turn off and unplug the treadmill. Using the Allen wrench provided, turn both left and right rear roller adjustment bolts 1/4 turn in the clockwise direction for the same amount, then turn on the main power switch of treadmill and let the belt run at the speed of 1-1.5 MPH. You should now walk on to the belt to determine if the belt is still slipping. Repeat the above procedure until the belt no longer slips.

ADJUSTMENTS

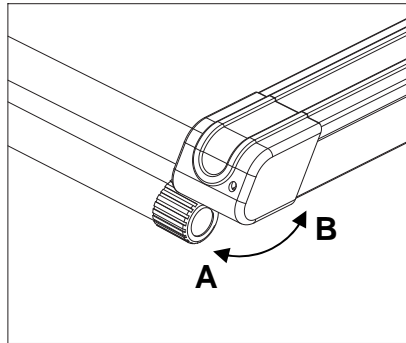

Incline Adjustment:

Place one hand on the rear end of main frame. Lift the main frame up then adjust the Incline Adjuster to the desired position.

2 Incline Degree Options:

3 % Incline degree when Incline Adjuster at Position A.

6 % Incline degree when Incline Adjuster at Position B.

LUBRICATION

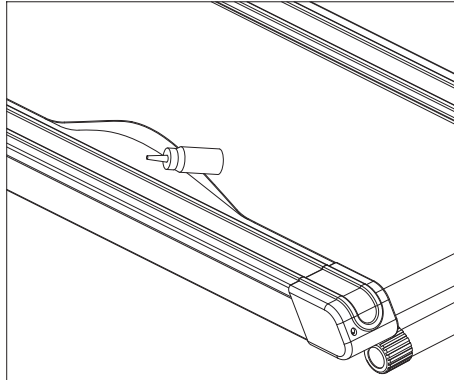

The treadmill has already been coated with "Silicone Oil" in advance. Silicone oil is a non-volatile oil and by the time you receive should have permeated through the belt. There will be no need to re-apply the oil under normal circumstances. To maintain the belt, "Silicone Oil" may be re-applied once the resistance has been increased and the belt starts rubbing against the running deck. To re-apply "Silicone Oil" to the treadmill, lift up the belt, one side at a time, and apply the oil directly to the center of the running deck. Allow the silicone oil to 'set' for one minute before using the treadmill.

Attention: Only use "Silicone Oil" lubricants for this equipment. **In addition, do not add any other type of oil; otherwise the treadmill will be damaged. Do not over-lubricate the walking board. Excess lubricant should be wiped off with a clean towel.**

TROUBLE SHOOTING & MAINTENANCE

WARNING: To prevent electrical shock, please turn off and unplug(ed) the treadmill before cleaning or performing routine maintenance.

CLEANING

The treadmill can be cleaned with a soft cloth and mild detergent. Do not use abrasives or solvents. Be careful not get excessive moisture on the display panel as this might cause an electrical hazard or electronics to fail.

Please keep the treadmill, especially, the console, out of direct sunlight to prevent screen damage.

STORAGE

Store the treadmill in a clean and dry environment. Ensure the master power switch is off and is in the off position and the power plug is un-plugged from the electrical wall outlet.

TROUBLE SHOOTING GUIDE

Problem	Potential Causes	Corrections
Treadmill will not start.	<ol style="list-style-type: none">1. Not plugged in.2. Safety tether key not connected.3. House circuit breaker tripped.4. Treadmill circuit breaker tripped.	<ol style="list-style-type: none">1. Put the power plug into the electrical wall outlet.2. Install the safety tether key.3. Reset or have an electrician replace the breaker in home.4. Wait five minutes and then press the switch back in.
Belt slips.	Belt not tight enough.	Adjust belt tension.
Belt hesitates When stepped on.	<ol style="list-style-type: none">1. Not enough lubrication applied onto the running deck.2. Belt is too tight.	<ol style="list-style-type: none">1. Apply silicone lubricant.2. Adjust belt tension.
Belt is off centered.	Running belt tension not even across the rear roller.	Center the belt.

TROUBLE SHOOTING & MAINTENANCE

Problem	Potential Causes	Corrections
Er 1 (Computer did not receive any signal for 30 seconds.)	<ol style="list-style-type: none"> 1. Bad communication for upper and lower controller. 2. The communicate signal from upper or lower controller is bad by interference from motor. 	<ol style="list-style-type: none"> 1. Check the cables are in good connection. 2. Turn off the Master Power Switch to the OFF position, wait 30 seconds, then turn on the Master Power Switch to the ON position. If the screen still shows Er 1, please notify your local Customer Service Center.
Er 3 (Over voltage protection trip.)	<ol style="list-style-type: none"> 1. Input AC power over voltage. 2. Chip for controller is damage. 	Turn off the Master Power Switch to the OFF position, wait 30 seconds, then turn on the Master Power Switch to the ON position. If the screen still shows Er 3, please notify your local Customer Service Center.
Er 4 (Excessive current from the controller.)	<ol style="list-style-type: none"> 1. Belt is too tight. 2. Belt rubs against the deck. 	<ol style="list-style-type: none"> 1. Adjust the belt tension. 2. Apply silicone lubricant or turn off the Master Power Switch to the OFF position, wait 30 seconds, then turn on the Master Power Switch to the ON position. If the screen still shows Er 4, please notify your local Customer Service Center.

TROUBLE SHOOTING & MAINTENANCE

Problem	Potential Causes	Corrections
Er 5 (Excessive drive motor current.)	Check your machine to make sure the running belt is without any abnormal interference.	Turn off the Master Power Switch to the OFF position, wait 30 seconds, then turn on the Master Power Switch to the ON position. If the screen still shows Er 5, please notify your local Customer Service Center.
Er 6 (The motor can not work.)	Check if the wire that connects to the motor is connected properly or not.	Reconnect the wire or turn off the Master Power Switch to the OFF position, wait 30 seconds, then turn on the Master Power Switch to the ON position. If the screen still shows Er 6, please notify your local Customer Service Center.
Er 7 (PCB did not receive any signal.)	<ol style="list-style-type: none"> 1. Bad communication for upper and lower controller. 2. The communicate signal from upper or lower controller is bad by interference from motor. 	<ol style="list-style-type: none"> 1. Check the cables are in good connection. 2. Turn off the Master Power Switch to the OFF position, wait 30 seconds, then turn on the Master Power Switch to the ON position. If the screen still shows Er 7, please notify your local Customer Service Center.
SAFE (Safety key is loose or unplugged.)	Check the position of the safety key.	Reset the safety key correctly.

WARM UP

Quadriceps Stretch

With one hand against a wall for balance, reach behind you and pull your right foot up. Bring your heel as close to your buttocks as possible. Hold for 15 counts and repeat with left foot up.

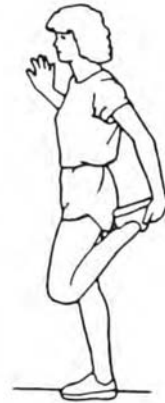

Inner Thigh Stretch

Sit with the soles of your feet together with your knees pointing outward. Pull your feet as close into your groin as possible.

Gently push your knees towards the floor. Hold for 10 counts.



Toe Touches

Slowly bend forward from your waist, letting your back and shoulders relax as you stretch toward your toes. Reach down as far as you can and hold for 15 counts.

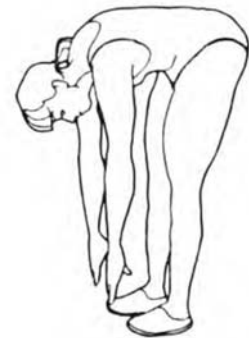

Hamstring Stretches

Sit with your right leg extended. Rest the sole of your left foot against your right inner thigh. Stretch toward your toe as far as possible. Hold for 15 counts. Relax and then repeat with left leg extended.



WARRANTY

MANUFACTURER'S LIMITED WARRANTY

Paradigm Health & Wellness warrants to the original purchaser that this product is free from defects in material and workmanship when used for the purpose intended, under the conditions that it has been installed and operated in accordance with Paradigm's Owner's Manual. Paradigm's obligation under this warranty applies to the following:

<u>COMPONENT</u>	<u>LENGTH OF WARRANTY</u>
Structural Frame	1 year
Motor	5 years
All Other Components (computer display, electronics, upholstery, foam, ball bearings, pulleys, belts, cables, wires, shocks, covers, tension, internal mechanism, wheels, pedals, knobs, accessories and hardware)	90 days

Exclusions from Warranty Coverage:

Paradigm does not warrant against and is not responsible for, and no implied warranty shall be deemed to cover, any product failure, product malfunction, or damages attributable to:

1. Improper installation and/or failure to abide by Paradigm's installation guidelines;
2. Use of this product beyond normal home use, or in an application for which it was not designed;
3. Cosmetic items such as scratches, dents or discolorations;
4. Damage caused by normal wear and tear, vandalism, accidental or by animals;
5. Any act of Nature (such as fire, flooding, snow, ice, hurricane, earthquake, lightning or other natural disaster), environmental condition (such as air pollution, mold, mildew, etc.), or staining from foreign substances (such as dirt, grease, oil, etc.);
6. Normal weathering due to exposure to sunlight, weather and atmosphere which can cause colored surfaces to, among other things, flake, chalk, accumulate dirt or stains.
7. Improper operation, alteration, handling, storage, abuse or neglect of the products.

Paradigm, using its sole discretion, will either repair or replace free of charge any part(s) proven to be defective under normal home use. Any repair or replacement shall provide no new warranty coverage, but shall retain only the remaining portion of the original product's warranty. This warranty is offered only to the original purchaser and is not transferable. Proof of original purchase is required.

Ordering Replacement Parts

Replacement parts can be ordered by emailing our customer service department:

Service@paradigmhw.com

Open Daily 8:00 AM - 5:00 PM (PST).

When ordering replacement parts please have the following information ready:

1. **Owner's Manual**
2. **Model Number**
3. **Description of Parts**
4. **Part Number**
5. **Date of Purchase**

FAX FORM

Paradigm Health & Wellness, Inc

EMAIL THIS FORM WITH YOUR RECEIPT OF PURCHASE TO
Service@paradigmhw.com *

NAME: _____

ADDRESS: _____

CITY _____ STATE _____ ZIP _____

TELEPHONE: (Day) _____

(Night) _____

SERIAL#: _____

MODEL#: _____

PURCHASE DATE: _____

PLACE OF PURCHASE: _____

PART #	DESCRIPTION	QTY

“YOUR ORDER WILL BE PROCESSED WITHIN 3 BUSINESS DAYS”

****This form can also be faxed to #: 626-810-2166***