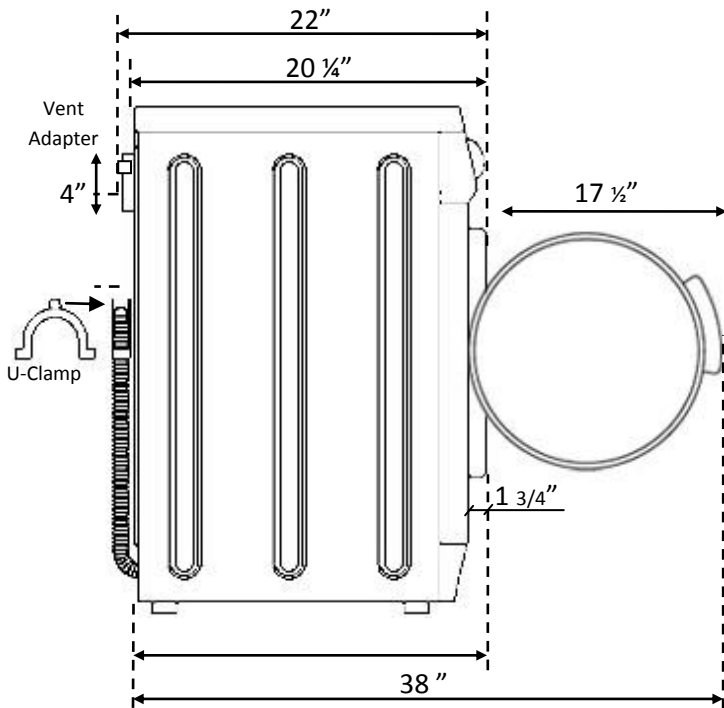
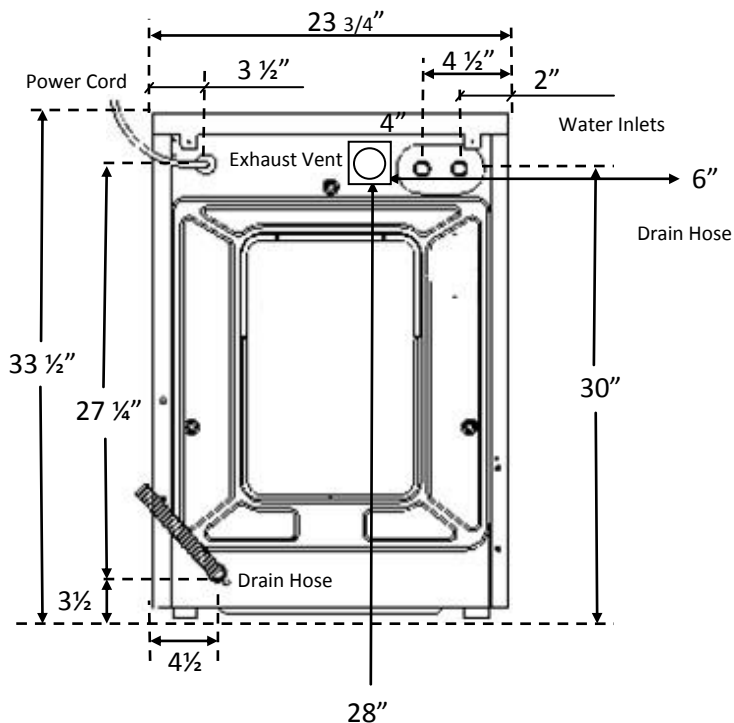

## DATA SHEET: EQUATOR SUPER COMBO

**SIDE VIEW**

**REAR VIEW**

 Product Model Number  
 EZ 4000 CV

Color	White / Silver
Capacity	13-lbs
Programs	14
Door Diameter/Swing	16"/180°
Weight (Net/Gross) lbs	161/168
Dryer Ventilation (Convertible)	Venting/Condensing
Wash or Dry Option Only	Yes
Wash or dry only option	Yes
Pre-Wash Function	Yes
Half-Heat Option	Yes
Stainless steel drum	Yes
Automatic door lock in wash	Yes
Door lock open in dry mode	Yes
Easy access coin-trap	Yes
Water Save Option	Yes
Drying Time	0-120 minutes
Spin Speed	1000 rpm.
Additive Dispenser	Automatic
Electrical	110V 60Hz 15A
Unit Dimension HxWxD (inch)	33.5 x 23.5 x 22
Warranty	1 Year Parts and Labor

Power cord length – 5' – Color White

Drain hose length – 5' Color Grey

Inlet hose length (2) – 5' Color Black with stainless connector

**Installation Location:**

- > Unit may be installed in recessed area, closet, or alcove.
- > Air Space Requirements: 2" on sides and 3" in front and back (from the case). Additional installation spacing needs to be considered for easy installation, servicing, and compliance with local codes or ordinances.
- > Floor must support at least 280 lbs. and be a solid, level surface.
- > When locating in a towable trailer or watercraft, position the machine over the axles or midship where movement is at a minimum. Block unit in to prevent extreme movement.

**Standpipe Drain System:**

- > In RV, installation needs a 1 1/2" (3.7 cm) diameter standpipe with the minimum carry-away capacity of 7 gallons (26 liters) per minute. An air break must be available at the standpipe to avoid siphoning.

**Floor Standpipe Drain:**

- > Top of standpipe must be at least 24" (60 cm) high and no higher than 40" (101 cm) from the bottom of the machine.

**Wall Standpipe Drain:**

- > 24" (60 cm) min; 40" (101 cm) max from the end of drain hose to the bottom of the machine.

**Sink Drain:**

The drain hose can be clamped to the sink using the U-Clamp provided the top of the sink is not higher than 40" (101 cm) from the bottom of the machine.

**Portability Kit Available:**

It comprises of a faucet adapter for direct faucet connection, Y-connector for single faucet connection and casters to make the unit portable.

**Mobile Home Installation:**

- > The dryer must be exhausted to the outdoors with the termination securely fastened to the mobile home structure. The exhaust must not be terminated beneath the mobile home. Provisions must be made for the introduction of outside air into the dryer. The free air opening shall not be less than 12 sq. inches.