

GO KIDDO

T5 *Carving Scooter*

Designed in California



Owner's Manual

Go-Kiddo T5 Owner's Manual - English V1 01/28/14

GO KIDDO
Fun to Ride

A child wearing a helmet and safety glasses is riding a Go-Kiddo T5 carving scooter. The child is leaning forward in a carving stance. The background is a blurred outdoor setting with trees and a building.

GO KIDDO T5 *Carving Scooter*

CONGRATULATIONS

on your purchase of a Go-Kiddo T5.

With the T5, we wanted to invite children to step outside and ride. The intention is to get them into exercising the whole body while playing. Go-Kiddo's unique ride is extremely engaging and offers the inherent fun and challenges of riding and propelling. The Go-Kiddo ride is intuitive and natural. It's what we call an active ride. The rider and vehicle form a propulsion system: the rider is part of the vehicle dynamics and vice-versa.

THE BENEFITS

Kids enhance their overall health and well-being by utilizing all of the major muscle groups and develop cardiovascular fitness in a low-impact and mentally engaging manner. Additionally, riding a Go-Kiddo CS provides enhanced opportunities for brain development because the rider crosses the three midlines of the body while riding (as discussed in the field of Educational Kinesiology). The Go-Kiddo ride also helps to build coordination, timing, agility, balance and confidence. Go-Kiddo carving scooters level the playing field for kids of all ages and skills. Everyone can ride and perform well. A proven adult fitness activity and a huge success in school PE programs across the country, this healthy and fun activity can be enjoyed for a lifetime.

***Go-Kiddo offers fitness disguised
as fun for the whole family!***

WARNINGS

to parents

- The Go-Kiddo T5 is a wheeled vehicle and, by its nature, riding it can pose the risk of falling and consequent injuries to the rider.
- We strongly advise to ride in a controlled environment during daylight hours on a wide, smooth, dry and predictable surface.
- Protect your children's head with an ANSI approved safety helmet. Never take chances.
- Additional protection can be provided with the use of knee and elbow pads.
- Please supervise your children while riding, teaching them the basic rules of riding safely and around other people.
- Avoid surfaces with sand, gravel, cracks, wet, grass, as the wheels may slip or get stuck throwing the rider off the vehicle and causing a fall.
- Do not play on streets.
- Do not play at night.
- Do not ride downhill.
- Do not lean back and pull the handlebar up (wheelie).
- Step on the middle of the foot deck area.
- Wear appropriate shoes and tie the shoe laces. Do not ride barefoot or with sandals.
- Do not use loose clothes that may get caught by the movement of the handlebar.
- Do not lean over the handlebar.
- Riding more than one person can be unsafe and easy to lose control.
- Do not coast with hands free - always hold with both hands on the handlebar.
- Always apply both brakes evenly. Practice braking.
- Never exceed the weight limit of 37kg (80lbs).

ASSEMBLY

(must be performed by an adult)

Remove the T5 from the box:

- A. Frame: Left Arm, Right Arm, Handlebar
(all connected by the brake cable)
- B. Front Structure
- C. Main Axle
- D. Tools
- E. Zip-tie
- F. Manual

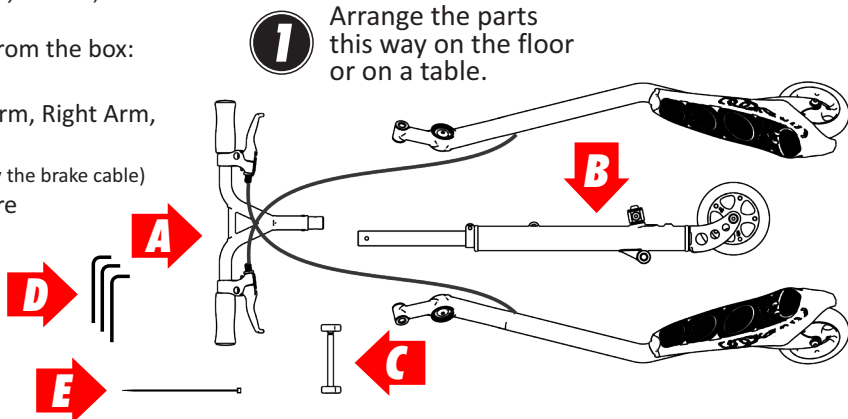

2 Attach the arms to the yoke.

 Allen wrench 5mm

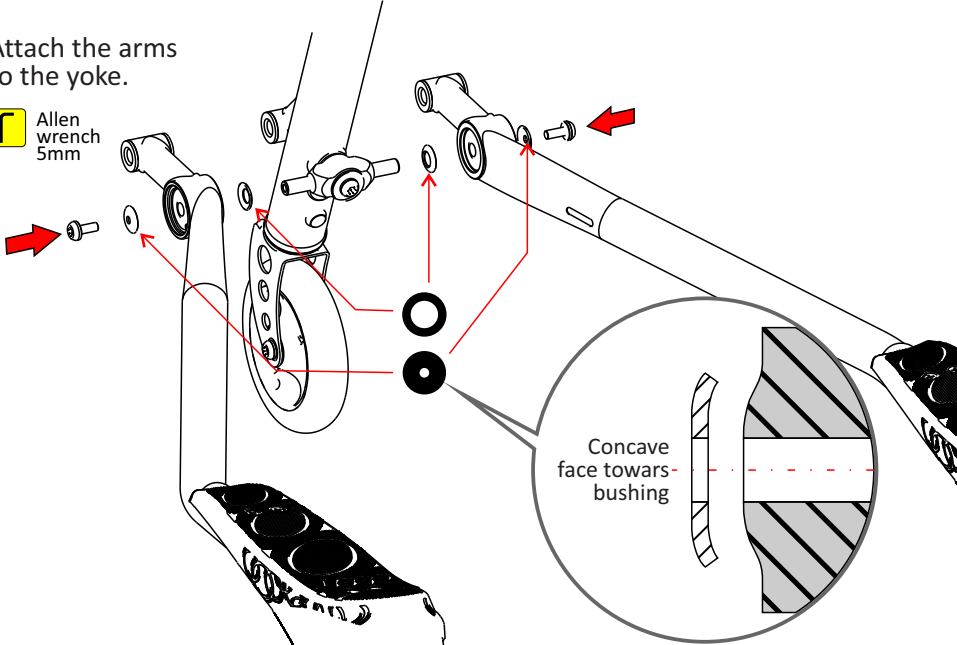

3 Insert the main axle through the 3 main frame parts and tighten the knobs.

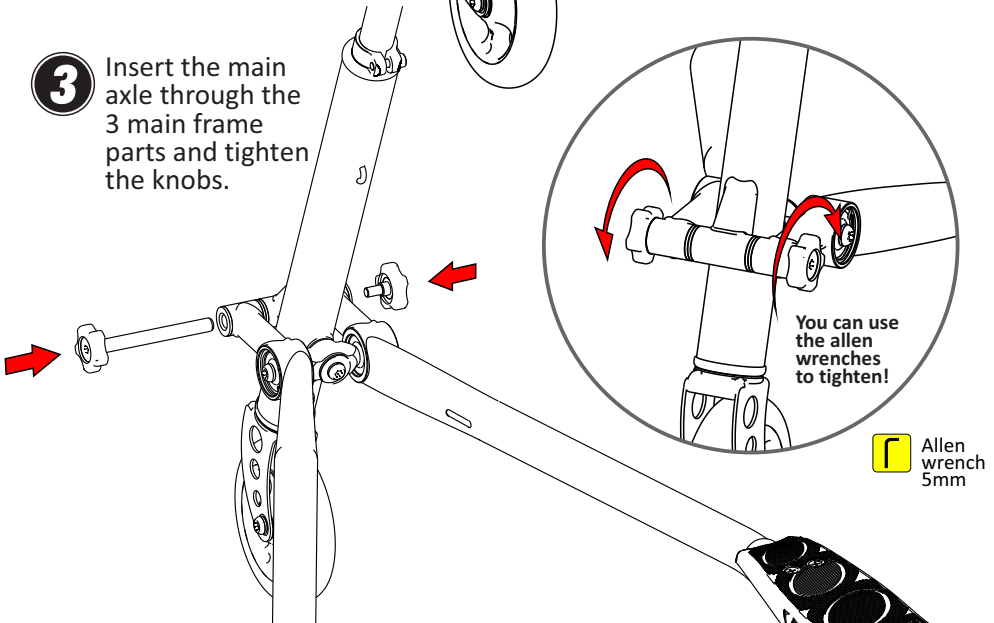

4 Install the handlebar.

Allen wrench 5mm

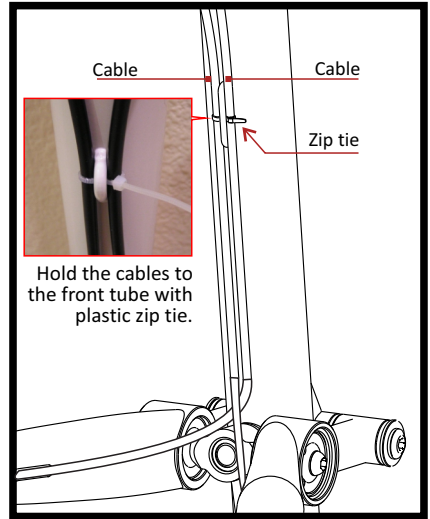
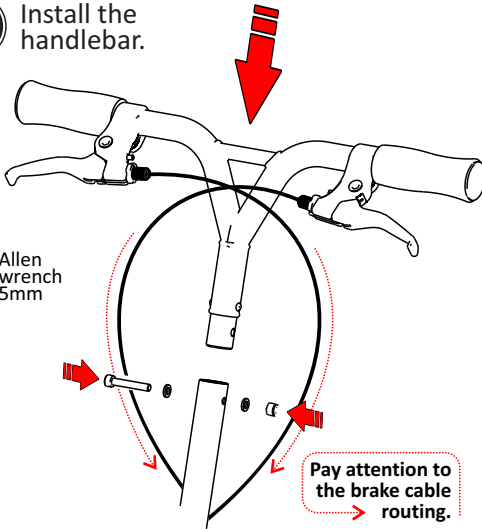

FOLDING

If you ever need to fold the frame:

- Remove the main axle.
- Collapse the frame.
- Mount the axle and bolt back through both arms.

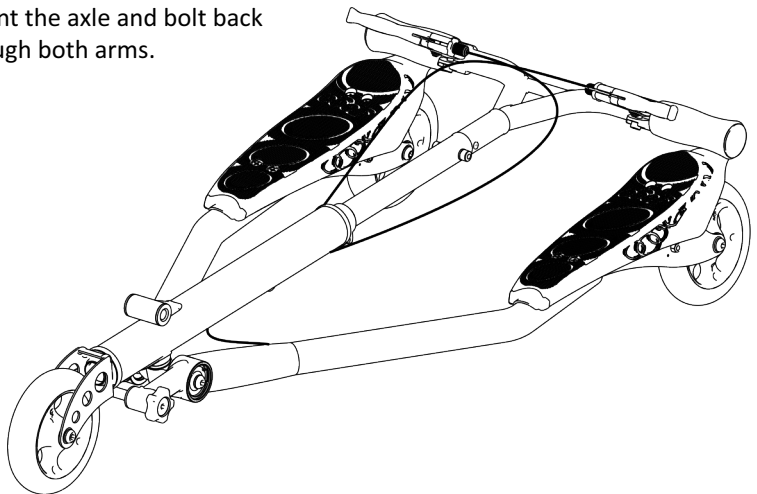

BRAKES

The T5 Jogo brakes are scrub brakes. A metal pad is pushed straight against the tire creating friction and stopping the wheel.

Attention: when applying brakes, rider must avoid locking and skidding the wheels - it will create a flat spot on the wheel circumference, damaging the wheel - rider will notice a bumpy roll.

BRAKE ADJUSTMENT:

The pad must be adjusted leaving a working gap between the pad and tire – 3mm (1/8")
At the pad you will find a bolt that holds the brake cable. Loosen the bolt, slide and stretch the cable, and re-tighten the bolt to adjust the brake. You may place any spacer of 3mm (1/8") in between the pad and tire while performing the adjustment and cable stretch. It's recommended the use a pair of pliers to pull and stretch the cable.

The brake should work efficiently at a half way squeeze of the brake lever at the handlebar.

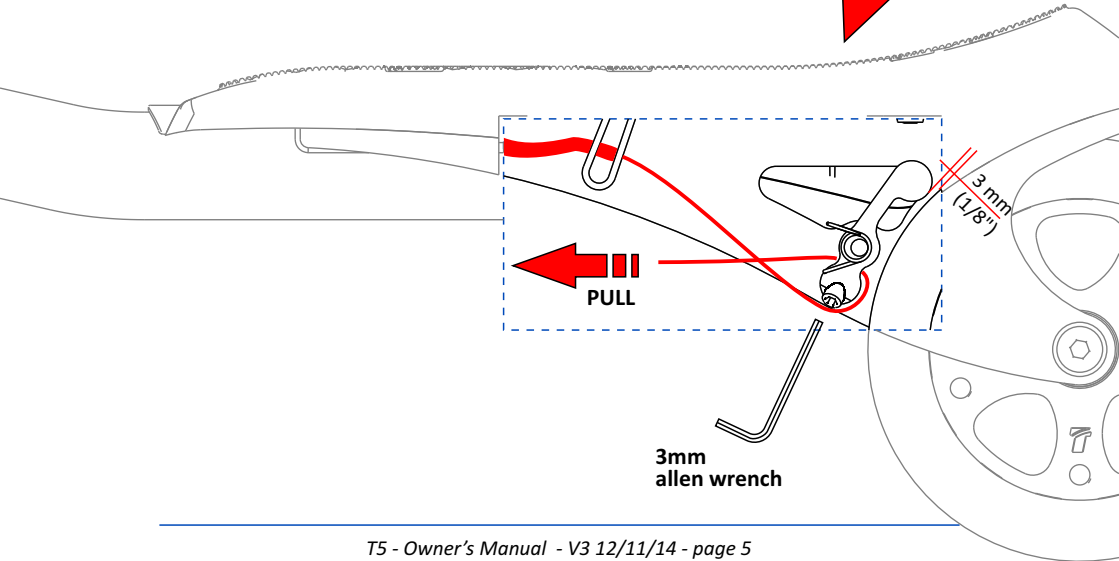
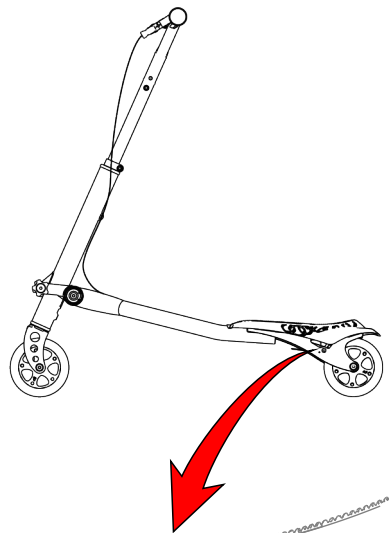

POLYURETHANE WHEELS

PU wheels perform better on smooth surface.

Small diameter wheels may get suddenly stopped by cracks, gravels, grass, tree branches or any small debris on the surface, and may cause a fall.

PU wheels may slide or slip over sand or wet surface and may cause a fall.

Observe the play area and remove debris. Instruct children to look for and avoid these elements.

Avoid locking the wheels while applying brakes. Apply brakes gently and evenly to both sides. Locking the wheels and skidding will create flat spots on the tire circumference, permanently damaging the wheels. You will feel a bumpy ride and bumpy braking. If this happen, replace the damaged wheel with a new one.

Wheels should last long with normal ride - approx 200 miles.

MAINTENANCE AND CARE

- Keep the tools supplied with the product.
- Regularly check the bolts by tightening.
- Raise and drop the whole vehicle from around 6 inches high and listen for clunky loose sounds.
- Spin the wheels to confirm they spin freely (due to brake and bearing) and are not bumpy.
- Test and adjust the brakes if needed.
- Check the alignment of the handlebar to the front wheel.
- Store the vehicle in a dry area. Do not leave exposed to rain or sprinklers.
- Avoid sand on the wheels and cambering area.
- If exposed to salty water, rinse it thoroughly, shake and let it dry in a ventilated area.

HOW TO USE

SCOOTING, CORNERING, CARVING, PROPELLING.

Children will start by pushing, kicking it to get some speed and carving wide turns. It can be used as a kick scooter... but the T5 is much more than that.

The rider can keep the vehicle moving by shifting their weight side to side while turning and leaning with the frame into the turn. This coordinated action is as intuitive as it is natural. It resembles the skiing motion.

HOW TO PLAY

Using cones spaced in a line will force the rider to carve left and right like an slalom course. You can create many different courses.

Throwing a ball (of soccer ball size) on the court will invite the rider to keep hitting and chasing the ball with the front wheel - stopping, starting, turning around and managing the timing to move the ball.

Follow the Leader: Another rider (on any scooter or bicycle) can be the leader and the rider will have to follow the same path as the leader. Chasing can be really fun and unpredictable.

Sports courts, tennis courts and other wide open areas are great to practice a large range of movements without restrictions.

Learn more games at www.go-kiddo.net/PEprogram.

VEHICLE LIMITATIONS



- Rider's weight Limit – 37kg (80lbs).
- Not designed to perform **Jumps** or **Stunts**.
- Not safe or built for skate park riding.
- Riding backwards can permanently bend and damage the frame.
- Brake efficiency will be reduced on wet surfaces.

INJURY AND ACCIDENT PREVENTION



- Use safety gear: Helmet, Pads.
- Avoid unsafe surfaces: wet, cracks, debris, sand.
- Avoid riding near curbs or cars.
- Do not play on the street or parking lots.
- Avoid crowded areas.
- Avoid playing at night.
- Focus on the ride, don't be distracted.
- Use appropriate shoes and clothes.
- Do not lean back or pull up the handlebars.
- Do not lean excessively over the handlebar.

SPECIFICATIONS

Vehicle Weight	Frame Material	Tires	Wheel Bearings	Brakes
5.0 kg (11.2 lbs)	STEEL	POLYURETHANE	608zz	Dual independent rear brakes – scrub pads on wheels, brake levers on handlebar.

Basic Dimensions

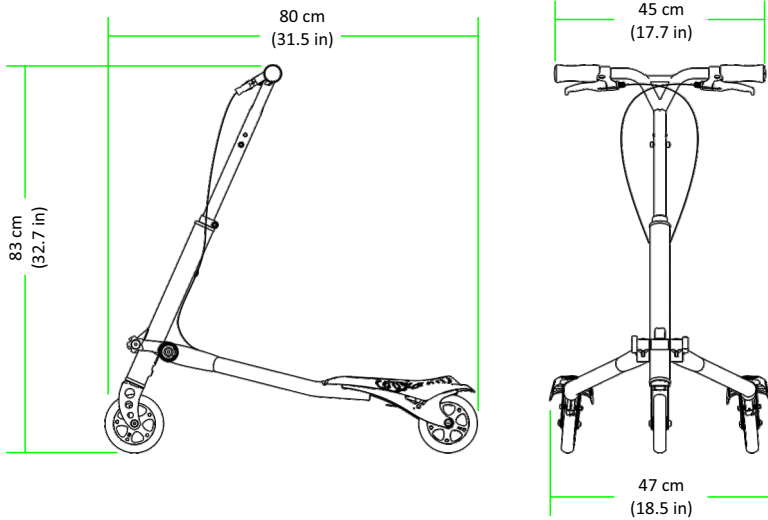

REPLACEMENT PARTS

You can get all parts for your T5 at a Go-Kiddo authorized dealer or by ordering online at www.go-kiddo.com

WARRANTY

The Go-Kiddo products are guaranteed to be free of defects when purchased new.

If you find any problem with a new product, please contact Go-Kiddo's Customer Service and we will take care of the issue. **Do not return the product to the store.**

Frame is covered against any structural defect or failure under normal use, with total replacement for the first 12 months from the date of purchase.

Certain parts are subject to wear and tear and are not covered by the warranty: wheels, brake parts, paint and trim.

COMPLIANCE

This Product was tested and complies with the following standards:

US: ASTM F963 (CPSC), EU: EN71 (CE).

The product was tested for toxic and hazardous materials according to CPSIA (US).

PATENT AND TRADEMARK

Go-Kiddo 3CV technology and vehicles are covered by international patents property of Go-Kiddo Riding Toys – California – USA.

Go-Kiddo trademark and logo are property of Go-Kiddo Riding Toys – California – USA.

Go-Kiddo Products are distributed under license by regional distributors in many countries.

CONTACT

Go-Kiddo Riding Toys

85 Industrial Way – suite F

Buellton, CA 93427 USA

Phone: 805-693-0800

www.go-kiddo.net

info@go-kiddo.net



Go-Kiddo Riding Toys

85 Industrial Way, Suite F
Buellton, CA 93427, USA
Phone: 805-693-0800
www.go-kiddo.net

GO KIDDO

Fun to Ride

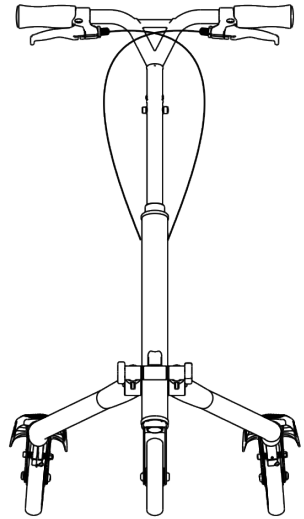
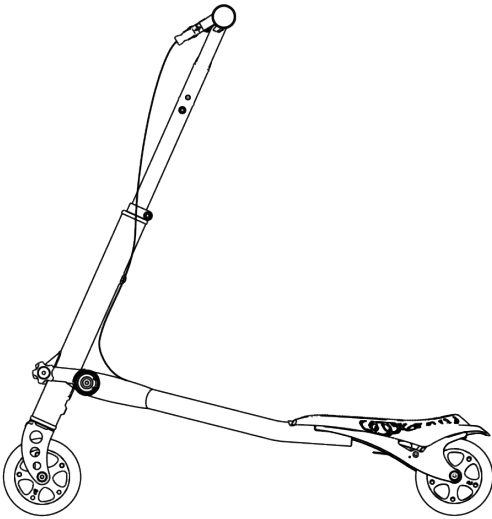

GO KIDDO **T5** *Carving Scooter*