



EARTH AUGER OPERATIONS MANUAL



**COMPLETE YOUR PURCHASE BY EITHER
REGISTERING ON LINE AT
WWW.THUNDERBAYPRODUCTS.COM OR BY
FILLING OUT YOUR WARRANTY CARD AND
MAILING IT IN.**



CONGRATULATIONS...

on purchasing your new **THUNDERBAY EARTH AUGER POWERHEAD**. We know that you are anxious to get right to work, but before you do, it is important that you take a few moments and familiarize yourself with your new Powerhead and its operating instructions. Please read your owner’s manual and take time to save time. We have worked hard to ensure that your new Powerhead will be one of the most trouble-free and satisfying pieces of equipment you have ever owned. With proper care, your powerhead will provide many years of service. Please take the time to register your new purchase as well as read this manual carefully to learn how to correctly operate and maintain your equipment.

PLEASE TAKE THE NEXT STEP TO REGISTER YOUR PURCHASE BY COMPLETING THE ENCLOSED WARRANTY CARD AND MAILING THE CARD TO THE FOLLOWING ADDRESS:

**THUNDERBAY PRODUCTS
104 YEAGER COURT
HUNTSVILLE, AL 35806
OR**



BY GOING TO WWW.THUNDERBAYPROCUCTS.COM WEBSITE AND FINDING THE WARRANTY ICON. CLICK ON THE WARRANTY ICON TO REGISTER YOUR PURCHASE.

CONTENTS

Introduction & Registration	2
Safety.....	3-4
Operation.....	5-8
Maintenance &Storage	8-9
Troubleshooting	10-11
Parts Diagrams & Parts Lists.....	12-17

INTRODUCTION

OWNER’S RESPONSIBILITY

CORRECT AND ACCURATE ASSEMBLY AND SAFE AND EFFECTIVE USE OF THE POWERHEAD IS THE OWNER’S RESPONSIBILITY!

- READ AND FOLLOW ALL SAFETY INSTRUCTIONS
- CAREFULLY FOLLOW ALL ASSEMBLY INSTRUCTIONS
- MAINTAIN POWERHEAD ACCORDING TO DIRECTIONS AND SCHEDULE IN YOUR OPERATOR'S MANUAL
- ENSURE THAT ANYONE WHO USES THE POWERHEAD IS FAMILIAR WITH ALL CONTROLS AND SAFETY PRECAUTIONS



! WARNING

WARNING SIGIFIES A DANGER WHERE YOU COULD BE SERIOUSLY INJURED OR HAVE AN ACCIDENT THAT COULD RESULT IN DEATH, IF NOT AVOIDED.

! CAUTION

CAUTION SIGNALS YOU CAN BE HURT OR THE EQUIPMENT SERIOUSLY DAMAGED, IF THE SAFETY INSTRUCTIONS THAT FOLLOW THIS SIGNAL WORD ARE NOT OBEYED

! IMPORTANT

IMPORTANT MEANS "READ THIS"! HELPFUL INFORMATION FOR CORRECT OPERATION, ASSEMBLY AND MAINTENANCE OF THE EQUIPMENT IS LISTED HERE.

! CALIF WARNING

CALIFORNIA PROPOSITION 65 STATES ENGINE EXHAUST FROM THIS PRODUCT CONTAINS CHEMICALS KNOWN TO CAUSE CANCER, BIRTH DEFECTS, OR OTHER REPRODUCTIVE HARM.



This symbol points out important safety instructions which if not followed could endanger your personal safety. Read and follow all instructions in this manual before attempting to operate this equipment.

TAKE NOTE OF ALL WARNING LABELS ATTACHED TO AUGER UNIT. IT IS IMPORTANT TO REALL ALL SAFETY PRECAUTIONS AND LOCATE ALL WARNING LABELS BEFORE OPERATING THIS PRODUCT.

SAFETY

OWNER'S RESPONSIBILITY

It is the owner's responsibility for accurate assembly and safe, effective use of the auger.

- Read and follow all safety instructions.
- Carefully follow all assembly instructions.
- Maintain the auger according to directions and schedule included in this operator's manual.
- Ensure that anyone who uses the auger is familiar with all controls and safety precautions.

SPECIAL MESSAGES

Throughout your manual you will find special messages to help bring potential safety concerns to your attention. Please read the entire manual carefully to help avoid injury and machine damage. Your manual is meant to be a helpful tool in preventing machine damage and personal injury. It also provides helpful operating tips and service information.

NOTE: Throughout the Manual, you will find general information that may help you in the operation and service of the powerhead

VITAL SAFETY PRECAUTIONS

Please read this section carefully. Operate the auger according to the safety instructions and recommendations outlined here and inserted throughout the text. Anyone who uses this auger must read the instructions and be familiar with the controls.

- ✓ Never carry running powerhead between holes.
- ✓ When engine is idling, the auger should not rotate. If it does, contact the service center for information.
- ✓ Always keep hands, feet, hair and any loose clothing away from any moving parts on engine and auger at all times.
- ✓ Always wear a protective hearing device.
- ✓ Never allow children to operate power auger. Do not allow adults to operate auger without proper instruction.
- ✓ Do not operate auger under influence of alcohol or drugs.
- ✓ Keep all screws, nuts and bolts tight.
- ✓ Engine should be turned off & allowed to cool. Spark plug wire must be removed from spark plug before any repairs.
- ✓ Muffler Temperature and nearby areas may exceed 150° F (65° C). Avoid these areas.
- ✓ Never run engine indoors or in an enclosed area. Engine exhaust contains carbon monoxide, an odorless and deadly gas.
- ✓ If the earth auger will not turn in the hole, turn engine off and allow it to cool before attempting to remove it.
- ✓ Use only original equipment parts from factory including all nuts and bolts.



CAUTION

HOT GASES ARE A NORMAL BY-PRODUCT OF A FUNCTIONING CATALYTIC CONVERTER. FOLLOW ALL SAFETY INSTRUCTIONS TO PREVENT BURNS AND FIRES.

CAUTION

TAKE GREAT CAUTION WITH MUFFLER, MUFFLER GUARD & OTHER PARTS OF ENGINE AS THEY BECOME EXTREMELY HOT DURING OPERATION. THESE PARTS REMAIN EXTREMELY HOT EVEN AFTER ENGINE HAS STOPPED.

GASOLINE FIRES AND HANDLING FUEL SAFELY

Fuels and their vapors are flammable and highly volatile! Fuel fires can spread quickly and even can be explosive! Never use fuel when a spark or flame may be present. Never use fuel where a potential source of ignition could occur. (Examples include: hot water heaters or space heaters, clothes dryer, electric motors, etc). Keep flames and sparks away from engine and fuel at all times to prevent fires.

PREVENTION OF GASOLINE FIRES

- ✓ Never fill your fuel tank with fuel inside a building including a basement, garage, barn, shed, house, porch, etc.
- ✓ Always fill fuel tank outside in a well ventilated area.
- ✓ Stop any engine and allow cooling before refilling tank.
- ✓ Never remove the fuel cap or add fuel while the engine is running.
- ✓ Never drain fuel from engine in an enclosed area.
- ✓ Always wipe up excess (spilled) fuel from engine before starting. Clean up spilled fuel immediately.
- ✓ Allow spilled fuel to dry, after wiping and before starting
- ✓ Always allow fuel fumes/vapors to escape from the area before starting engine.
- ✓ Test the fuel cap for proper installation and tightness before starting and using engine.
- ✓ Always run the engine with fuel cap properly installed on the engine and gas cap vent screw unscrewed.
- ✓ Replace any fuel cap that allows gas to spill or leak.
- ✓ Never smoke near any fumes/vapor or while refilling engine fuel tank.
- ✓ Do not store unit with fuel in the fuel tank in a confined space. Fuel and fuel vapors are highly explosive.
- ✓ Always check that gas cap vent screw is tightly secured.
- ✓ Never pour fuel from engine fuel tank.
- ✓ Never siphon fuel by mouth to drain fuel tank.
- ✓ Always have an adult fill the fuel tank.
- ✓ Never allow an adult or anyone under the influence of drugs or alcohol to fill engine.
- ✓ Never allow children to fill the engine or operate this unit.

PREVENTION OF BURNS AND FIRES

- ✓ Never remove the muffler guard from the engine.
- ✓ Never touch the muffler guard because it is extremely hot and will cause severe burns.
- ✓ Never touch parts of the engine that become hot after operation.
- ✓ Always keep materials and debris away from muffler guard and other hot parts of the engine to avoid fires.
- ✓ This engine is designed to operate using a catalytic converter which contributes to the engine's compliance with the EPA.

WARNING CARBON MONOXIDE POISONING

Fuel driven engines contain carbon monoxide in their exhaust. Even if you do not see or smell carbon monoxide; the deadly, colorless, tasteless, odorless gas may be present in the exhaust. Any enclosed areas of poor ventilation can potentially house deadly levels of carbon monoxide for days. If inhaled, any level of carbon monoxide can cause headaches, drowsiness, nausea, dizziness, confusion and eventually death. **If you experience any of these symptoms, seek fresh air and medical attention immediately.**

PREVENTING CARBON MONOXIDE POISONING

- ✓ Never run the engine indoors.
- ✓ Carbon monoxide can reach dangerous levels very quickly. Never try to ventilate engine exhaust indoors.
- ✓ Never run engine outdoors where exhaust fumes may be pulled into a building.
- ✓ Exhaust fumes are trapped easily and may not disperse. Never run engine outdoors in a poorly ventilated area (Examples include: hilly terrain, thickets or a large hole you are working in.)
- ✓ Never run engine in an enclosed or partially enclosed area such as: tents, open garages, car ports, buildings that are enclosed on one or more sides, or basements.
- ✓ Always point the exhaust and muffler away from the operator.
- ✓ Never point the exhaust muffler towards anyone. People should always be many feet away from the operation of the engine and its attachments.

ASSEMBLY TOOLS REQUIRED

Two (2) 9/16" Wrenches

ASSEMBLY INSTRUCTIONS (SEE FIGURE 1)

1. Insert output shaft of Y43 transmission (A) in the open end of Flex Coil Shock Top (B)
2. Line up bolt holes through Flex Coil Shock Top and output shaft of the transmission
3. Place included 3/8 -16 x 1.5" bolt (C) through bolt hole
4. Hand-thread 3/8-16" lock nut (D) onto bolt
5. Using two 9/16" wrenches, securely tighten nut and bolt

Y43 and YZ06 are shown. Instructions also apply to YZ08 and YZ10 augers

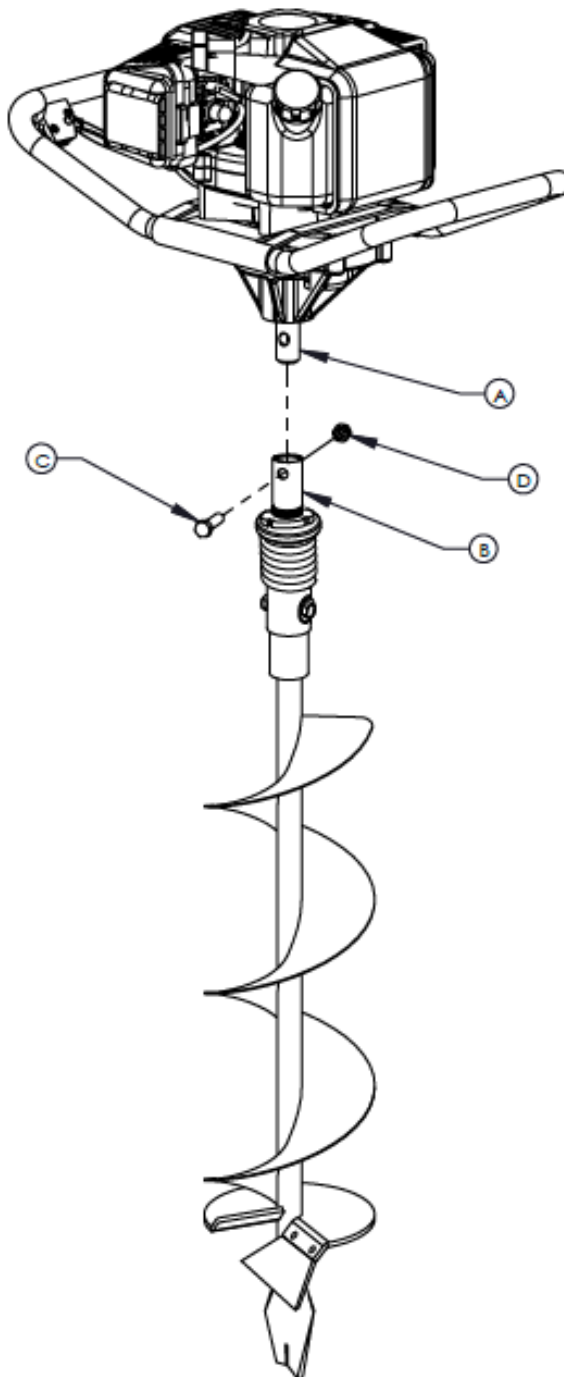

**Need Help?
PLEASE CALL**



During the assembly process or while operating or maintaining your auger, if you have any questions, please call our Authorized Service Center at the toll free number listed above.

Figure 1

⚠ CAUTION

NEVER ALTER/MODIFY ENGINE OR AUGER IN NO WAY ALTER OR MODIFY THE ENGINE FROM HOW IT CAME FROM THE FACTORY. SERIOUS INJURY OR DEATH MAY OCCUR IF IT IS ALTERED IN ANY WAY. ALWAYS DISCONNECT SPARK PLUG WIRE FROM SPARK PLUG WHEN WORKING ON OR REPLACING PARTS FOR THE ENGINE OR AUGER AND KEEP IT AWAY FROM THE SPARK PLUG. WHEN OPERATING ENGINE, ALWAYS WEAR HEARING PROTECTION!



PLEASE DO NOT START YOUR EARTH AUGER UNTIL YOU HAVE READ THE PREVIOUS SECTION OF THIS MANUAL IF YOU HAVE READ THESE, FOLLOW THE STEPS BELOW TO START YOUR EARTH AUGER.

NEVER STORE ENGINE WITH GAS IN THE TANK INDOORS. FUEL AND FUEL VAPORS ARE HIGHLY FLAMMABLE.

NEVER MIX FUEL AND OIL DIRECTLY IN ENGINE GAS TANK USE ONLY NON-METAL, PORTABLE FUEL CONTAINERS APPROVED BY THE UNDERWRITER'S LABORATORY (U.L.) OR THE AMERICAN SOCIETY FOR TESTING & MATERIALS (ASTM).

AN ADULT MUST ALWAYS HANDLE AND FILL THE ENGINE WITH FUEL.

ALWAYS HANDLE FUEL IN A WELL VENTILATED AREA, OUT DOORS AWAY FROM FLAMES OR SPARKS.

OPERATION

STEPS FOR WORKING ON ENGINE OR AUGER

- Turn off engine switch.
- Disconnect spark plug wire from spark plug.
- Securely place disconnected spark plug wire safely away from spark plug and any other metal parts. This must always be done or arcing may occur between spark plug wire and metal parts.
- Replace or repair the part on the engine or auger.
- Check all parts that were repaired, or removed during repair, to ensure that they are secure and fit correctly.

NOTE: All repair parts must come from the factory. Never replace parts that are not specifically designed for the engine or auger.

- Replace spark plug wire.

PREPARING ENGINE FOR STARTING

Make sure the black throttle cable housing is seated all the way into the brass ferrule at the engine side of the cable before attempting to start your powerhead engine.

GAS AND OIL QUALITY

To operate the engine, we recommend using 2-cycle oil. This will help to ensure that the engine operates correctly throughout the life of the engine. Use unleaded regular gas only.

MIXTURE

Run earth auger with a 40:1 ratio.

GAS	OIL	RATIO
1 gallon	3.2 ounces	40:1
2 gallons	6.4 ounces	40:1
5 gallons	16 ounces	40:1

MIXING FUEL AND FILLING GAS TANK

MIXING FUEL

- Fuel must be mixed in a container outside in a well ventilated area.
- Fill certified fuel container 1/4 full of recommended fuel.

Add recommended amount of 2 cycle oil.

- Screw container cap on straight and tight.
- Shake the container to mix fuel and oil.
- Unscrew gas cap slowly to vent, add the remainder of fuel requirements.
- Wipe away any spilled fuel or oil and allow to evaporate before moving or transporting.

⚠ IMPORTANT

NEVER RUN ENGINE ON STRAIGHT GAS ONLY. THIS ENGINE USES A GAS/OIL MIXTURE. FAILURE TO RUN ON FACTORY RECOMMENDED MIXTURE WILL RESULT IN ENGINE DAMAGE



CAUTION

ALWAYS HANDLE FUEL IN A WELL VENTILATED AREA, OUTDOORS, AWAY FROM FLAMES OR SPARKS.

DO NOT START ENGINE IF FUEL IS SPILLED. WIPE OFF EXCESS FUEL AND ALLOW TO DRY. REMOVE ENGINE FROM AREA TO AVOID SPARKS.

Need Help? PLEASE CALL



During the assembly process or while operating or maintaining your auger, if you have any questions, please call our Authorized Service Center at the toll free number listed above.

FILLING GAS TANK

- ✓ When unit has been in operation, always shut-off engine and allow engine to completely cool before refilling the gas tank.
- ✓ Always move to a well ventilated outdoor area away from flames and sparks.
- ✓ Always clean debris from area around the gas cap to keep fuel clean.
- ✓ Remove gas cap slowly and always place the cap on a clean, dry surface.
- ✓ Carefully add fuel without spilling.
- ✓ When filling tank, do not over-fill gas tank. Allow space for fuel to expand.
- ✓ Once tank is full, replace gas cap and tighten. Wipe off any spilled fuel and allow tank to dry before starting engine.

NORMAL OPERATION

- ✓ The Thunderbay Powerhead requires approximately a two hour break-in period before the clutch will transfer maximum power. During this break-in period clutch slippage may occur. Make sure that the clutch is always kept free of oil or other moisture for efficient operation.
- ✓ When drilling holes, do not place excessive body weight on the unit. The unit will operate more efficiently with a shaving action caused by the weight of the unit itself.
- ✓ Never run engine indoors. Exhaust fumes are deadly.
- ✓ This is not an Ice Auger. Do not use an earth auger in the ice.
- ✓ When attaching auger to powerhead, align hole at top of auger shaft with the output shaft hole. Insert 3/8-16 x 1-1/2" bolt and secure bolt with provided 3/8" bi-way lock nut using a wrench.

IMPORTANT NOTE:

The measured sound power level at the operator's position is approximately 100 dBLWA and is guaranteed not to exceed 106 dBLWA. The mass of the powerhead is 21.7 lbs. (9.9 kg.)



! WARNING

MAKE SURE THE UNIT IS IN A STABLE POSITION BEFORE PULLING STARTER.

WHEN THE UNIT STARTS TO FIRE OR RUN, RELEASE THE THROTTLE CONTROL MOMENTARILY WITH YOUR RIGHT HAND AND RETURN YOUR LEFT HAND TO THE HANDLEBAR POSITION TO MAINTAIN CONTROL AND STABILITY OF THE UNIT WITH BOTH HANDS

STARTING AND STOPPING ENGINE

- ✓ Move engine outdoors to a well ventilated area to ensure you are safe from carbon monoxide poisoning.
- ✓ Make sure you are in an area away from flames or sparks to avoid ignition of vapors if present.
- ✓ To ensure proper air flow, remove all debris from air cleaner holes and gas cap.

COLD ENGINE START

To start engine for the first time or after the engine has cooled off or after running out of fuel.

1. Position the choke lever to **RUN**.

NOTE: Choke must be in the RUN position when pushing or using the primer bulb.

2. Prime unit until primer hose is filled with gas.

NOTE: When using the primer bulb, allow the bulb to return completely to its original position between pushes.

3. Move choke lever to **CHOKE** position.

NOTE: **CHOKE** position is defined by moving the choke lever as far to the **CHOKE** position as possible.

4. Push rocker switch to the **ON** position.

5. Squeeze throttle control with right hand. Grasp starter handle with left hand and pull out slowly, until it pulls slightly harder. Without letting starter handle retract, pull rope with a rapid full arm stroke. Let it return to its original position very slowly until unit fires or runs. Repeat this step every time the starter rope is pulled.

NOTE: If engine fails to start after 5-6 pulls, push primer 1 time and pull starter rope again.

6. After engine starts running, move choke lever to **HALF CHOKE** position until unit runs smoothly.

NOTE: **HALF CHOKE** is defined when the choke lever is between **CHOKE** and **RUN**.

7. Move choke lever to **RUN** position and move throttle to desired speed.

NOTE: Run at full throttle when possible. Do not let unit idle for extended periods of time.

8. To stop engine, push rocker switch to **OFF** position.

! CAUTION

ALWAYS HANDLE FUEL IN A WELL VENTILATED AREA, OUT DOORS, AWAY FROM FLAMES OR SPARKS.

ALWAYS WEAR A PROTECTIVE HEARING DEVICE.

DO NOT START ENGINE IF FUEL IS SPILLED.

WIPE OFF EXCESS FUEL AND ALLOW TO DRY REMOVE ENGINE FROM AREA TO AVOID SPARKS.

IF AUGER IS MOUNTED TO ENGINE, ALL SAFETY GUARDS MUST BE SECURELY ON TO AVOID SERIOUS INJURY.

STARTER ROPE CAN CAUSE AN UNANTICIPATED JERK TOWARDS ENGINE PLEASE FOLLOW INSTRUCTIONS TO AVOID INJURY.

NEVER LEAVE ENGINE RUNNING WHILE UNATTENDED.

TURN OFF AFTER EVERY USE.

NEVER CARRY POWERHEAD AND AUGER BETWEEN HOLES WHILE ENGINE IS RUNNING.

WARM ENGINE START

1. Move choke lever to **CHOKE** position.

NOTE: **CHOKE** position is defined by moving the choke lever as far to the **CHOKE** position as possible.

- Continue with Step 5 of Cold Engine Starting.

HOT ENGINE START

1. Continue with Step 5 of Cold Engine Starting.
2. If engine does not fire, refer to Step 1 of Warm Engine Starting.

DO NOT ATTEMPT TO START ENGINE IN THE FOLLOWING WAYS:

- ✓ **DO NOT USE STARTING FLUID.**
- ✓ **DO NOT SPRAY FLAMMABLE LIQUIDS OR VAPORS INTO AIR CLEANER, CARBURETOR OR SPARK PLUG CHAMBER.**
- ✓ **DO NOT REMOVE SPARK PLUG AND PULL ON STARTER ROPE. FLAMMABLE FUEL CAN SPRAY OUT & IGNITE FROM A SPARK FROM SPARK PLUG.**





⚠ CAUTION

TO PREVENT ACCIDENTAL STARTING:

ENGINE MUST BE TURNED OFF TO COOL AND SPARK PLUG WIRE MUST BE REMOVED FROM SPARK PLUG BEFORE CHECKING AND ADJUSTING ENGINE OR EQUIPMENT.

TEMPERATURE OF MUFFLER AND NEARBY AREAS MAY EXCEED 150° F. (65 °C). AVOID THESE AREAS.

CHECK AUGER OFTEN FOR LOOSE NUTS AND BOLTS. KEEP THESE ITEMS TIGHTENED.

NEVER STORE ENGINE WITH FUEL IN THE TANK INSIDE A BUILDING. POTENTIAL SPARKS MAY BE PRESENT FOR IGNITION OF FUEL AND FUEL VAPORS.

AN ADULT MUST ALWAYS DO MAINTENANCE AND REPAIR ON ENGINE AND AUGER.

ENGINE MUST BE SHUT-OFF, COOL, AND SPARK PLUG WIRE REMOVED BEFORE ANY REPAIR OR MAINTENANCE CAN BE DONE.

MAINTENANCE AND STORAGE

AUGER MAINTENANCE

- ✓ The gear case has 4 oz. of grease installed at the factory.
- ✓ Keep all screws, nuts, and bolts tight.
- ✓ For cold weather operation, store the unit in a cool environment.
- ✓ Transferring the unit from a warm to a cold place can cause the buildup of harmful condensation.
- ✓ If blade performance decreases, turn unit off and disconnect spark plug wire. Carefully inspect cutting edge of blade for any signs of wear. If blades show any of these signs, they need to be sharpened or replaced.

ENGINE MAINTENANCE

COOLING FINS

Cooling fins, air inlets and linkages must be free from any debris before each use.

AIR FILTER

Never run engine without air cleaner properly installed. Added wear and engine failure may occur if air cleaner is not installed on engine.

Service the air cleaner after 20 hours of operation or every 3 months of use.

CLEAN FILTER DAILY IN EXTREMELY DUSTY CONDITIONS!

**Need Help?
PLEASE CALL**



⚠ IMPORTANT

NEVER TWIST AIR FILTERS WHEN CLEANING. ALWAYS PRESS!

During the assembly process or while operating or maintaining your auger, if you have any questions, please call our Authorized Service Center at the toll free number listed above.

STEPS FOR CLEANING RING STYLE FOAM FILTER

SEE PARTS EXPLOSION ON PAGE 16

1. Wash in warm water with mild soap until dirt and debris are removed. Press filters when washing, do not twist.
2. Rinse in warm water until soap and dirt are removed.
3. Dry filter by wrapping in a clean cloth and pressing filter until it is dry.
4. Apply oil to the entire filter.
5. Remove excess oil.
6. Attach the filter and air cleaner cover to the engine.

STEPS FOR CLEANING BLOCK STYLE FOAM AIR FILTER

NOTE: SEE PARTS EXPLOSION ON PAGE 16

1. Before removing the air filter cover, move the choke lever to the choke position. **(Figure 1)**
2. To remove air filter cover, get away the bolt on the cover and squeeze the latch tabs on both sides of the cover. **(Figure 2)**
3. Once the latch tabs are released, remove the air filter cover by rotating the cover away from the engine. **(Figure 3)**
4. Remove the white plastic cover and the foam filter element **(Figure 4, 5)** and replace with anew oiled filter, or clean the original foam filter with warm water and mild soap by following the previous steps for Cleaning Air Filter. Remember to thoroughly oil the foam filter with 30 or 40 weight motor oil and squeeze out any excess oil.
5. Reinstall the foam filter and white plastic cover, pressing it in place to ensure that the foam is fully seated into its sealed position. **(Figure 6)**
6. Replace the air filter cover so that it fully snaps into place and is secured by the latch tabs. Check that the cover is securely attached by pulling slightly on the cover. If the cover doesn't move when pulled, it is secure.



Figure 1



Figure 2



Figure 3



Figure 4



Figure 5



Figure 6



CAUTION

TO AVOID INJURY OR DEATH, NEVER SIPHON FUEL BY MOUTH.

NEVER STORE EARTH AUGER WITH FUEL IN THE GAS TANK INSIDE AN ENCLOSED AREA OR BUILDING.

TO PREVENT ACCIDENTAL STARTING:

ENGINE MUST BE TURNED OFF AND COOL AND SPARK PLUG WIRE MUST BE REMOVED FROM SPARK PLUG BEFORE CHECKING AND ADJUSTING ENGINE OR EQUIPMENT.

AN ADULT MUST ALWAYS DO MAINTENANCE AND R-E PAIR ON ENGINE AND AUGER.

ENGINE MUST BE SHUT-OFF, COOL, AND SPARK PLUG WIRE REMOVED BEFORE ANY REPAIR OR MAINT-E NANCE CAN BE DONE.

SPARK PLUG

The recommended spark plug is a L8RTC.

1. Check spark plug at the beginning of each season.
2. Disconnect the spark plug cap, and clean any debris from around the spark plug area.
3. Remove spark plug and replace if any of the following occur; pitted electrodes, burned electrodes, cracked porcelain, or deposits around electrodes.
4. After analysis, seat spark plug and tighten with spark plug wrench.
 - Reinstall original spark plug, tighten additional 1/2 turn.
 - Installing new spark plug, adjust spark plug gap to .028" and tighten additional 1/8 – 1/4 turn.

NOTE: Loose spark plug may overheat and damage engine. Over tightened spark plug may damage threads in the cylinder head.

CARBURETOR

Never tamper with factory setting of the carburetor.

TRANSPORTING YOUR EARTH AUGER

1. Never transport engine inside an enclosed space or vehicle. Fuel or fuel vapors may ignite causing serious injury or death.
2. If fuel is present in the fuel tank, transport in an open vehicle in an upright position.
3. If an enclosed vehicle must be used, remove gas into an approved red fuel container. **DO NOT siphon by mouth.**
4. Run engine to use up the fuel in the carburetor and fuel tank. Always run engine in a well ventilated area.
5. Wipe away any spilled fuel from engine and earth auger. Allow to dry.

LONG TERM STORAGE

Note: If your earth auger will not be used for more than one month, then prepare it for long term storage.

STEPS FOR LONG TERM STORAGE

1. Add fuel stabilizer according to manufacturer's instructions.
2. Run engine for 10-15 minutes to ensure that the stabilizer reaches the carburetor.
3. Remove the remainder of the fuel from the gas tank into an approved fuel container.
4. Remove auger from powerhead and apply a thin layer of grease to the output shaft.
5. Store auger and powerhead (engine) in a vertical position.
6. Remove all debris from auger and powerhead (engine).



⚠ CAUTION

PRACTICE SAFETY AT ALL TIMES. BEFORE ATTEMPTING ANY MAINTENANCE OR REPAIR, SPARK PLUG WIRE MUST BE DISCONNECTED AND ENGINE MUST BE TURNED OFF AND ALLOWED TO COOL.

⚠ IMPORTANT

WHEN CALLING FOR SERVICE, WITH QUESTIONS REGARDING YOUR AUGER OR FOR PARTS, PLEASE HAVE THE FOLLOWING INFORMATION AVAILABLE WITH YOUR REQUEST:

1. AUGER MODEL NUMBER
2. AUGER SERIAL NUMBER
3. IF PARTS ARE NEEDED, PLEASE PROVIDE PART NUMBERS AND QUANTITIES

SERVICE INFORMATION

THUNDERBAY TAKES PRIDE IN EACH AND EVERY UNIT WE PRODUCE. WE BUILD QUALITY AND DURABILITY INTO THE DESIGN OF OUR PRODUCTS. HOWEVER, NO AMOUNT OF CAREFUL DESIGN ON OUR PART AND NO AMOUNT OF CAREFUL MAINTENANCE BY YOU, CAN GUARANTEE A REPAIR-FREE LIFE FOR YOUR MACHINE. MOST REPAIRS WILL BE MINOR AND EASILY FIXED BY FOLLOWING THE SUGGESTIONS IN THE TROUBLESHOOTING SECTION OF THE MANUAL.

THIS SECTION WILL HELP YOU LOCATE AND ISOLATE THE CAUSES OF COMMON PROBLEMS AND IDENTIFY HOW TO BEST FIX YOUR UNIT.

WE WILL ALWAYS BE GLAD TO ANSWER ANY QUESTIONS YOU HAVE, OR HELP YOU FIND SUITABLE ASSISTANCE. TO ORDER PARTS OR INQUIRE ABOUT WARRANTY, CALL, WRITE OR E-MAIL US AT THE ADDRESS FOUND BELOW, UNDER THE SECTION ORDERING REPAIR PARTS.

**Need Help?
PLEASE CALL**



**THUNDERBAY PRODUCTS
104 YEAGER COURT
HUNTSVILLE, AL 35806**

**1 855 691 5969
www.thunderbayproducts.com**

During the assembly process or while operating or maintaining your auger, if you have any questions, please call our Authorized Service Center at the toll free number listed above.



TROUBLESHOOTING COMMON PROBLEMS

Y43 Model

PROBLEM	POSSIBLE CAUSE	REMEDY/ACTION
Engine will not start	1. Power switch off	1. Flip switch to ON position
	2. Spark plug wire disconnected	2. Connect spark plug wire to spark plug
	3. Out of fuel	3. Refuel
	4. Spark plug wet, faulty or improperly gapped	4. Clean, replace or gap spark plug
	5. Throttle control not held open	5. Squeeze throttle control when pulling recoil handle
	6. Fuel line hose not positioned in bottom of gas tank	6. Push fuel line down into fuel in gas tank
Engine runs rough, floods during operation	1. Dirty air filter	1. Clean or replace air filter
	2. Choke partially engaged	2. Turn off choke
	3. Carburetor out of adjustment	
Engine is hard to start	1. Stale fuel	1. Drain old fuel and replace with fresh fuel. Use gas stabilizer additive at end of season.
	2. Spark plug wire loose	2. Make sure spark wire is securely attached to spark plug
	3. Dirty carburetor	3. Clean carburetor, use gas stabilizer, new gas can
	4. Throttle control not held open	4. Prime unit 3 more times, squeeze throttle when pulling recoil handle
Engine misses or lacks power	1. Clogged gas tank	1. Remove and clean
	2. Clogged air filter	2. Clean or replace
	3. Carburetor out of adjustment or bad	3. Consult Service Center
	4. Spark plug wet, faulty or improperly gapped	4. Clean, replace or gap spark plug
Engine runs, then quits	1. Gas cap not venting	1. Open manual venting gas cap screw all the way open (counterclockwise)
	2. Plugged fuel filter	2. Clean or replace
	3. Carburetor out of adjustment or bad	
Engine revs too high	1. Carburetor out of adjustment	
Auger turns at idle	1. Idle speed too high	1. Adjust idle speed lower
	2. Broken clutch spring	2. Replace spring
Auger turns, but has no power	1. Choke on	1. Turn off choke after engine is running
	2. Carburetor out of adjustment	2. Consult Service Center
	3. Broken transmission	3. Consult Service Center
	4. Worn clutch shoes	4. Replace clutch shoes and spring
	5. Worn engine lower seat	
Auger jumps	1. Blade damaged	1. Replace with new blade
Auger cuts slowly	1. Dull blade	1. Buy new blade, or have blade sharpened at factory
	2. Damaged fishtail point	2. Replace fishtail point

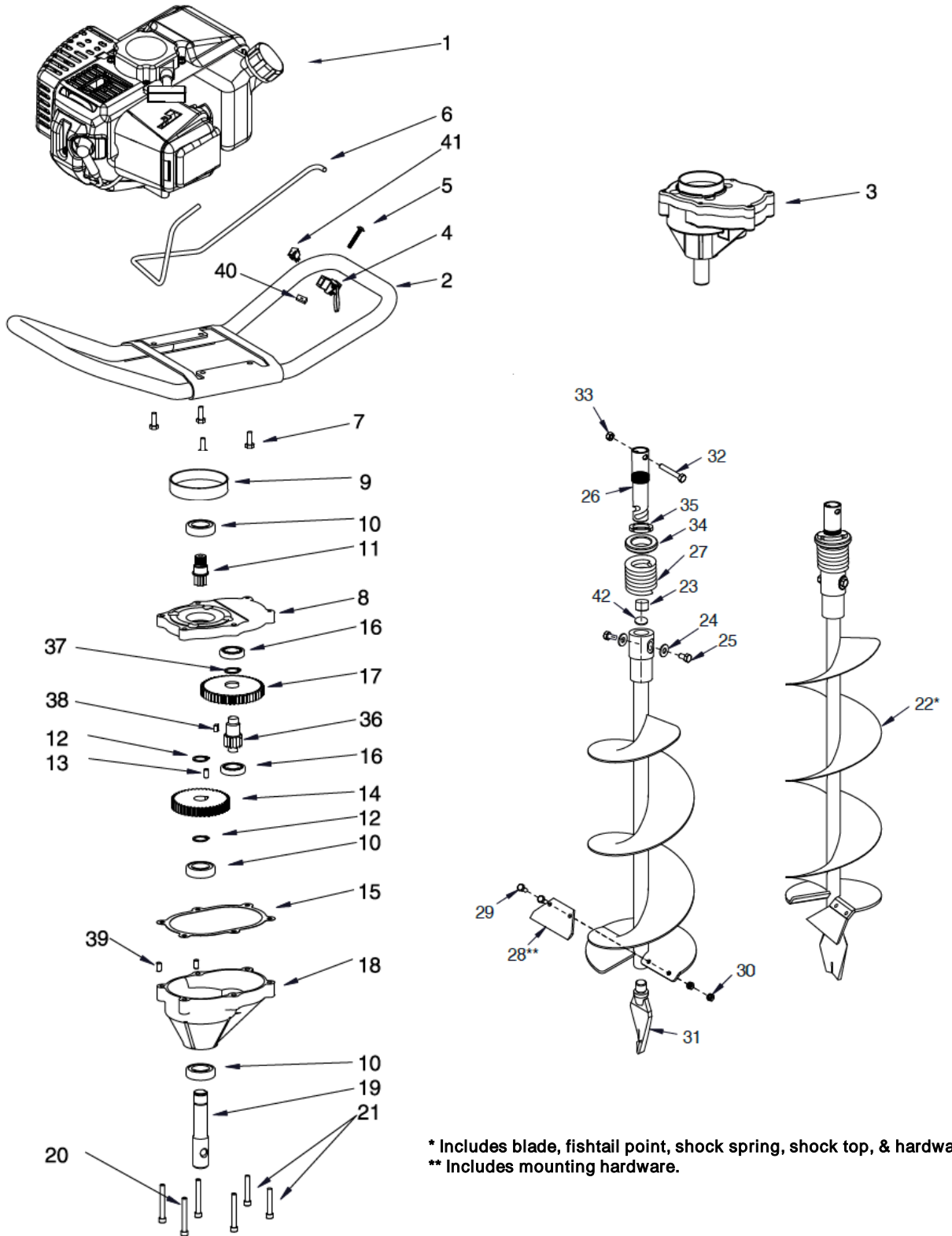

* Includes blade, fishtail point, shock spring, shock top, & hardware.
** Includes mounting hardware.



Y43 POWERHEAD AND AUGER & ACCESSORY PARTS LIST

Y43 Model

KEY NO.	PART NO.	DESCRIPTION	QTY.
1	Y43.01	GAS ENGINE, 43 CC	1
2	Y43.06	HANDLEBAR, FOAMED	1
3	Y43.05	TRANSMISSION COMPLETE	1
4	Y43.03A	TRIGGER ASSEMBLY	1
5		BOLT 10-24 X 1-1/4 PHILLIPS TRUSS HD	1
6	Y43.02	THROTTLE CABLE	1
7		BOLT 1/4-20 X 3/4 HH GR5 BLK	4
8	Y43.05-01	GEAR CASE TOP	1
9	Y43.04	CLUTCH DRUM	1
10		BALL BEARING R12 DOUBLE LIP	3
11	Y43.05-04	GEAR 7T PINION THREADED, 5/8" THREAD	1
12	Y43.05-05	SNAP RING	2
13	Y43.05-03	DOWEL PIN STEEL 1/4" X 1/2"	1
14	Y43.05-06	GEAR 44T 3/4" HOLE	1
15	Y43.05-02	GASKET	1
16		BALL BEARING R10	2
17	Y43.05.01-02	GEAR 48T	1
18	Y43.05-08	GEARCASE BOTTOM	1
19	Y43.05-07	SHAFT OUTPUT 7/8"	1
20		BOLT 1/4-20 X 1-1/2 SHCS	2
21		BOLT 1/4-20 X 2 SHCS F-T	4
GEAR ASSEMBLY			
17	Y43.05.01-02	GEAR 48T	1
36	Y43.05.01-01	GEAR 10T	1
37	GB/T894.1	SNAP RING 19	1
38	GB/T1096	KEY 5X5X12	1

KEY NO.	PART NO.	DESCRIPTION	QTY.
22*	YZ04	EARTH AUGER 4"	1
	YZ06	EARTH AUGER 6"	1
	YZ08	EARTH AUGER 8"	1
	YZ10	EARTH AUGER 10"	1
23	YZ06.00-05	CUSHION RUBBER	1
24	GB93-87	SPRING WASHER 12	2
25	YZ06.00-04	BOLT M12X1.25X14	2
26	YZ06.00-01	SHOCK TOP 1-PC	1
27	YZ06.00-03	SHOCK SPRING	1
28**	YD04	EARTH BLADE, 4"	1
	YD06	EARTH BLADE, 6"	1
	YD08	EARTH	1
	YD10	EARTH BLADE, 10"	1
29		BOLT 1/4-28 X 5/8 HH GR5	2
30		NUT 1/4-28 BI-WAY LOCK	2
31	YZ06.02	FISHTAIL POINT SHARPENED	1
32		BOLT 3/8-16 X 1-1/2 HH	1
33		NUT 3/8-16 HEX LOCK BI-WAY	1
34	YZ06.00-02	SPRING PLATE	1
35	GB/T810	NUT M27X1.5	1
39	Y43.05-09	POSITION PIN	2
40	YZ06.00-06	NUT	1
41		SWITCH, ROCKER	1
42	YZ06.00-07	WASHER	1

* Includes blade, fishtail point, shock spring, shock top, & hardware.

** Includes mounting hardware.

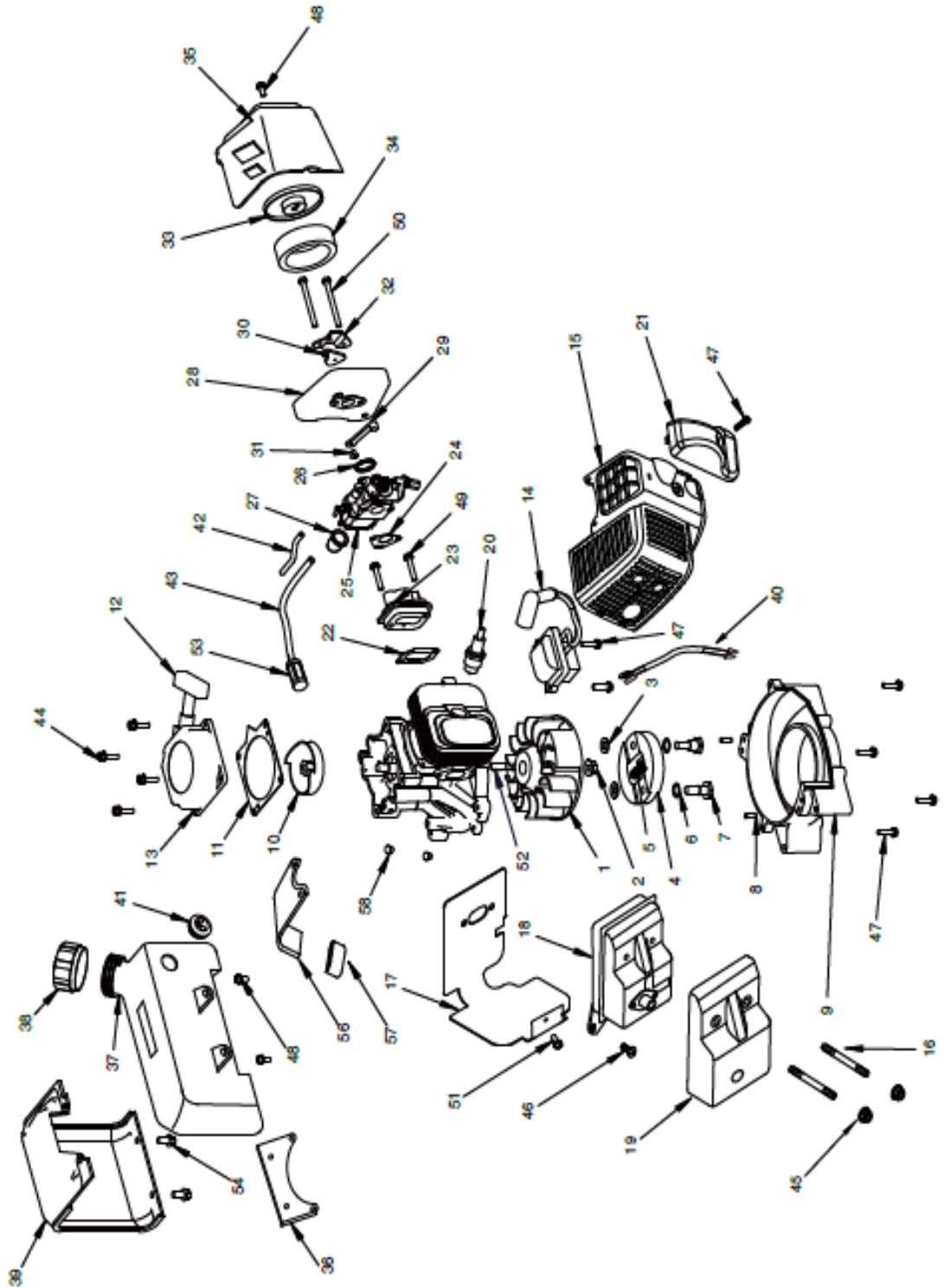



Y43 ENGINE PARTS LIST (SEE PARTS EXPLOSION PAGE 16)

Y43 Model

KEY NO.	PART NO.	DESCRIPTION	QTY.
1	430001	FLYWHEEL, MAGNETO	1
2	430002	NUT, FLANGE M8	1
3	430003	WASHER, ROTOR	2
4	430004	CLUTCH ROTOR ASSEMBLY	1
5	430005	SPRING, CLUTCH	1
6	430006	WASHER, SPRING	2
7	430007	BOLT, SHOULDER	2
8	430008	PIN, LOCATING	2
9	430009	MOUNT RING & SHROUD	1
10	430010	RECOIL CLUTCH	1
11	430011	PLATE, RECOIL	1
12	430012	HANDLE, RECOIL (STANDARD)	1
13	430013	RECOIL ASSEMBLY WITH STANDARD HANDLE	1
14	430014	IGNITION COIL	1
15	430015	SHROUD, ENGINE	1
16	430016	BOLT, STUD M6 X 62MM	2
17	430017	GASKET, MUFFLER	1
18	430018	MUFFLER	1
19	430019	COVER, MUFFLER	1
20	430020	SPARK PLUG	1
21	430021	COVER, ENGINE SHROUD	1
22	430022	GASKET, INTAKE	1
23	430023	WINDPIPE, INTAKE 43CC/51CC	1
24	430024	GASKET, CARBURETOR	1
25	430025	CARBURETOR	1
26	430026	O-RING, CARBURETOR	1
27	430027	PRIMER BULB	1
28	430028	BASE, INTAKE	1
29	430029	CHOKE LEVER, SIDE MOUNT	1
30	430030	CHOKE COVER	1
31	430031	SCREW, THROTTLE LEVER	1
32	430032	PLATE, INTAKE COVER ADAPTER	1
33	430033	COVER, AIR FILTER	1
34	430034	AIR FILTER	1
35	430035	COVER, INTAKE	1
36	3.040.001	GAS TANK SUPPORT PLATE	1

KEY NO.	PART NO.	DESCRIPTION	QTY.
37	430036	GAS TANK	1
38	430037	GAS CAP, MANUAL VENTING	1
39	2.011.00213	SHROUD, GAS TANK	1
40	430038	ENGINE WIRE	1
41	430039	GROMMET, 2-HOLE GAS TANK	1
42	430040	HOSE, PRIMER LINE	1
43	430041	HOSE, FUEL LINE	1
44	430042	BOLT W/WASHER PHILLIPS HH	4
45	430043	NUT, FLANGE M6	2
46	430044	BOLT W/WASHER M5 X 12MM	2
47	430045	BOLT W/WASHER PH M5 X 18MM	7
48	430046	BOLT HH M5 X 20MM	3
49	430047	BOLT W/WASHER M5 X 25MM	2
50	430048	BOLT M5 X 50MM	2
51	430049	BOLT M4X 10MM	1
52	430050	KEY, FLYWHEEL	1
53	430051	FILTER, FUEL	1
54	7.1.15.002	SELF-DRIVE SCREW ST4X8	2
55		SWITCH, ROCKER	1
56	430053	GAS TANK BOARD	1
57	430054	RUBBER BUSHING	1
58	430055	GAS TANK RUBBER PLATE	2



During the assembly process or while operating or maintaining your auger, if you have any questions, please call our Authorized Service Center at the toll free number listed above.



THUNDERBAY PRODUCTS EARTH AUGER LIMITED WARRANTY