

6 in



♥ **BEST IN CLASS:**  
3 SAFETY VALVES  
COOKS 70% FASTER  
ENERGY EFFICIENT  
TENDERIZES MEATS  
PRESERVES NUTRIENTS & ENHANCES FLAVORS  
LIMITED LIFETIME WARRANTY



**12**QT.

**USE & CARE**



8.75 in

ALUMINUM/ALUMINIO  
PRESSURE COOKER/ OLLA DE PRESIÓN

# TABLE OF CONTENTS

<b>Important Safeguards.....</b>	<b>1</b>
<b>What is a Pressure Cooker?.....</b>	<b>2</b>
<b>Before First Use.....</b>	<b>3</b>
<b>Important Safety Tips .....</b>	<b>4</b>
<b>How to Order Replacement Parts .....</b>	<b>5</b>
<b>Using Your Pressure Cooker.....</b>	<b>6</b>
<b>How to Clean Your Pressure Cooker.....</b>	<b>8</b>
<b>Tips and Hints.....</b>	<b>9</b>
<b>Frequently Asked Questions.....</b>	<b>10</b>
<b>Cooking Times.....</b>	<b>11</b>

This is a UL-listed appliance. Reading the following SAFETY TIPS is strongly recommended.

## IMPORTANT SAFEGUARDS

To minimize the risk of personal injury or damage to your kitchen, these safety precautions should always be followed:

1. Read all instructions.
2. Do not touch hot surfaces; use handles or knobs.
3. Close supervision is necessary when the pressure cooker is used near children.
4. Do not use this pressure cooker for pressure frying with oil.
5. Do not place pressure cooker in a heated oven.
6. Extreme caution must be used when moving a pressure cooker containing hot liquids.
7. Do not use the pressure cooker for anything other than its intended use.
8. This appliance cooks under pressure. Improper use may result in scalding injury. Make certain the unit is properly closed before operating. See "USING YOUR PRESSURE COOKER."
9. Do not fill over 2/3 full. When cooking foods that expand during cooking such as rice or dried vegetables, do not fill over 1/2 full. Overfilling may cause a risk of clogging the vent pipe and developing excess pressure. See "COOKING TIMES."
10. Do not cook foods such as applesauce, cranberries, pearl barley, oatmeal or other cereals, split peas, noodles, macaroni, rhubarb, or spaghetti. These foods tend to foam, froth and sputter, and may block the pressure release device.
11. Always check the pressure release devices for clogging before use. NEVER REMOVE THE PRESSURE REGULATOR UNTIL PRESSURE HAS BEEN RELEASED.
12. Do not open the pressure cooker until the unit has cooled and all internal pressure has been released. If the handles are difficult to separate, this indicates that the cooker is still pressurized—do not force open. Any pressure in the cooker can be hazardous. See "USING YOUR PRESSURE COOKER."
13. Be sure that handles are assembled and fastened properly before each use. Cracked, broken or charred handles should be replaced.
14. When the normal operating pressure is reached, turn the heat down so all the liquid, which creates the steam, does not evaporate.
15. Do not attempt to repair or modify any part of this pressure cooker. If repair is needed, please contact TTU customer service. For contact information please see pg. 5.

## 16. SAVE THESE INSTRUCTIONS

# WHAT IS A PRESSURE COOKER?

A pressure cooker is a saucepan with a special lid that locks securely into place. As the pressure cooker is heated, the dry air is automatically exhausted and the moist, heated air is sealed inside, increasing the pressure within the cooker. When the optimum pressure is reached, internal temperatures in the cooker are raised above the normal boiling point of water, causing foods to cook faster. The higher pressure and temperature speed cooking and tenderize meats naturally. Before using the pressure cooker for the first time, it is important to become familiar with the various parts and features of the unit and to read the **“USING YOUR PRESSURE COOKER”** section. Here are some of the key components of the pressure cooker:

## GET TO KNOW YOUR PRESSURE COOKER

THIS PRESSURE COOKER IS INTENDED FOR  
HOUSEHOLD USE ONLY

### WELCOME

Discover how fast and easy it is to prepare a wide variety of delicious meals that focus on good health and nutrition while still tasting great. Designed for today’s fast paced, health-conscious lifestyle, your pressure cooker is ideal for preparing fast, tasty meals designed to keep your family healthy and fit. Pressure-cooking preserves flavors and nutrients, tenderizes meat, and cooks foods three to ten times faster than other methods.



- |                      |                |                                     |
|----------------------|----------------|-------------------------------------|
| ① Pressure Regulator | ⑤ Lid Handle   | ⑨ Overpressure Plug                 |
| ② Vent Pipe          | ⑥ Sealing Ring | ⑩ Safety Valve                      |
| ③ Safety Lock        | ⑦ Lid          | ⑪ Vent Strainer Cap<br>(Inside Lid) |
| ④ Lock Pin           | ⑧ Body         |                                     |

The **PRESSURE REGULATOR** ① fits onto the **STEAM VENT PIPE** ②. When the proper operating pressure (12 lbs/sq. in.) is reached, the pressure regulator will rock gently and control the pressure inside the cooker.

The gentle rocking motion of the pressure regulator is an indication that the proper cooking pressure is being maintained.

The **SAFETY LOCK** ③ automatically releases air from the unit as you begin heating the pressure cooker. As pressure builds, the safety lock slides up, causing the **LOCK PIN** ④ to lock the lid in place. The safety lock will be in the up position when the cooker is pressurized. When the safety lock is in the down position, the unit is depressurized and safe to open.

The **SEALING RING** ⑥ fits around the inside rim of the lid (see below) and forms a pressure-tight seal between the **LID** ⑦ and the **BODY** ⑧ of the cooker. If the vent pipe becomes clogged and excess pressure cannot be released normally, steam is automatically released by the **OVERPRESSURE PLUG** ⑨. This is a safety device and you should check its condition periodically.

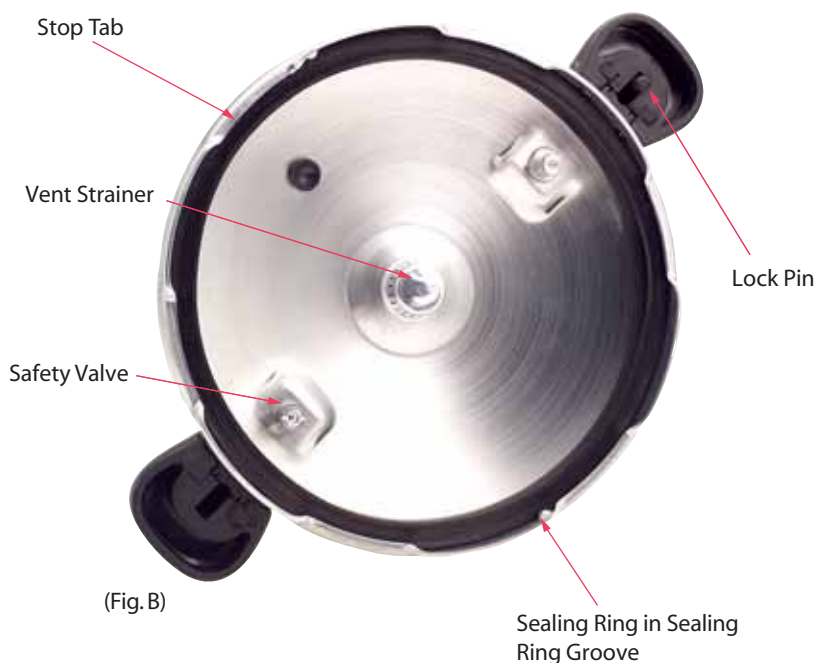

## BEFORE FIRST USE

Remove the sealing ring by pulling it out of the inside rim of the lid. Wash the ring, lid, and body in warm soapy water to remove any packaging material and manufacturing lubricant. Rinse the ring, lid, and body in warm water, and dry. When replacing the sealing ring, be careful to fit it under the stop tabs located on the inside rim on the lid. The **SAFETY VALVE** ⑩ works with the pressure regulator to release any excess pressure. The **VENT STRAINER CAP** ⑪ can prevent foods from clogging the steam vent pipe. If SAFETY VALVE and VENT STRAINER fail, the overpressure plug will pop out and release the excess pressure.

## IMPORTANT SAFETY TIPS

Our pressure cooker is designed to prepare delicious, healthy meals in less time than traditional cooking methods. Used properly, your pressure cooker is one of the safest appliances in your kitchen. Ensuring safe operation is as easy as following these simple rules:

- 1. Do not overfill the pressure cooker.**
- 2. Always visually examine the steam vent pipe to make sure it is clear before locking the lid in place.**
- 3. Always fully close and lock the lid of the pressure cooker.**
- 4. Never open the cooker when it contains pressure (when the safety lock is in the up position, there is pressure in the cooker).**
- 5. Replace the overpressure plug when it becomes hard, deformed, cracked, worn or pitted, or when replacing the sealing ring. Replace the sealing ring when it becomes hard, deformed, cracked, worn, pitted, or soft and sticky.**

Understanding these instructions is important. So that you understand why these instructions must be followed every time you use the cooker, please read the following:

### 1. Never overfill the pressure cooker.

If the cooker is overfilled, this may cause the pressure relief services to stop functioning properly. The pressure regulator is designed to maintain safe cooking pressures. It relieves excess pressure through the vent pipe as it rocks back and forth. The overpressure plug is a backup pressure relief valve designed to release excess pressure if the pressure regulator fails to operate properly. Neither one can perform their function if there are obstructions in the other. Obstructions can occur if the pressure cooker is overfilled. For most foods, it is safe to fill the pressure cooker up to 2/3 full. There are a few foods that expand to the point that the pressure cooker should never be more than 1/2 full when cooking them. There are also foods that, because of the foaming, frothing, and sputtering that occur during cooking, should never be pressure-cooked. The pressure cooker is marked at the 1/2 and 2/3 full levels so that you always know how much liquid is in the unit.

Be sure to not let any of the foods you are cooking extend above the maximum fill level (Fig. C)



(Fig. C)

## 2. Visually examine the steam vent pipe for obstructions before using the cooker.

To examine the steam vent, unscrew the pressure regulator (Fig. A #1) on the top of the lid. Next, turn over the lid and gently remove the strainer cover from the base of the vent ( Fig.D1 and D2). Hold the lid up to a light to confirm that the vent is clear of any obstruction. If the steam vent pipe is blocked, remove the obstruction before using the cooker. Replace the strainer cover before using the unit. Failure to remove an obstruction from the steam vent will result in pressure building to unsafe levels.

## 3. Always fully lock the lid of the unit.

The lid handles must be aligned directly over the body handles. The specially designed lugs in the lid are designed to lock in place when the lid is properly closed. However, if the lid is not properly seated, the lugs will not lock the lid onto the body. It is possible that pressure may build inside the cooker and cause the cover to come off, possibly resulting in bodily injury or property damage.

## 4. Never open the cooker when it is pressurized.

Opening the pressure cooker while it is pressurized will cause the contents of the cooker to erupt, which could cause bodily injury or property damage.

## 5. Replace the overpressure plug and the sealing ring.

Replace if they become hard, deformed, cracked, worn, pitted, or soft and sticky; or every two years, whichever occurs first. Frequent contact with oily foods will cause the sealing ring to deteriorate. Deterioration will result in the ring becoming either hard and inflexible or soft and tacky. Should this occur, immediately replace the ring, as failure to do so could result in pressure release, causing great bodily harm and/or property damage. Do not apply cooking oil to the sealing ring.

# HOW TO ORDER REPLACEMENT PARTS

**To order replacement parts (Pressure Regulator or Sealing Ring), send a money order in the amount of \$8.00 US Dollars to: Tabletops Unlimited, at the address below. Contact Customer Service for further details and instructions on ordering replacement parts.**

Tabletops Unlimited Inc.; 23000 S. Avalon Blvd; Carson, CA 90745  
Attention: Customer Service Department, Pressure Cooker Replacement.  
Phone number: 310-549-6000 • Web address: [www.ttucorp.com](http://www.ttucorp.com)  
Customer Service e-mail: [customerservice@ttucorp.com](mailto:customerservice@ttucorp.com)



(FIG. D1)

Steam Vent  
with Strainer  
Removed



(FIG. D2)

# USING YOUR PRESSURE COOKER

Having familiarized yourself with the components of the unit and their purposes, it is important that you read the following information about pressure-cooking and the step-by-step instructions before you begin to cook.

Pressure cookers create moist heat under pressure to cook the food. Moist heat cooking requires a cooking fluid, generally water; however, more advanced cooks may wish to use wine or other flavored liquids instead. Because the cooking process is done in a sealed vessel, very little liquid is lost. Hence, you will need only about 8 oz. more liquid than is needed for the finished dish. You can achieve the best results by following these simple step-by-step instructions:

1. Prepare your ingredients using the recipe you have selected.
2. If you are cooking vegetables, soups, or desserts, skip to step 5.
3. Many meat and poultry recipes call for braising. To braise, pour the required amount of cooking oil called for in the recipe into the cooker and preheat uncovered over medium heat for 1 to 2 minutes.
4. Put the meat or poultry in cooker and sear thoroughly on all sides until it is deep brown and crisp. Monitor the heat to prevent burning. Season. Less seasoning may be required, as foods cooked in a pressure cooker retain more of their natural flavor. Remove pressure cooker from heat and allow it to cool slightly before adding liquid to the unit.
5. Pour the amount of liquid called for in the recipe into the pressure cooker.

Handy Tip: When preparing more than one item at a time, make sure that the items being prepared have the same cooking times and temperatures.

## IMPORTANT REMINDER

Always visually examine the steam vent pipe before using your pressure cooker



6. To lock the lid in place, align the “V” mark on the lid with the arrow on the body handle. Rotate the lid until the cover drops into position. Lock the lid in place by rotating it clockwise until the lid handle is aligned with the body handle. The pressure cooker lid is properly locked in place when the lid handles are directly above the body handles. **DO NOT OVER-ROTATE THE LID** (Fig F., Fig G.).



7. Place the pressure regulator in the vent pipe, screwing it in until it moves down no further. The pressure regulator will fit loosely on the vent pipe. It will not touch the top of the pressure cooker lid.



8. Heat the pressure cooker until the pressure regulator begins a gentle rocking motion. A medium to high heat setting is best. The safety lock will move up and down, releasing dry air and a little steam. Once the cooker has reached its operating pressure and temperature, the safety lock will seal and remain in the up position until the pressure is released. The overpressure plug will rise slightly and seal as well.

9. Calculate cooking times when the pressure regulator begins to rock gently. Gradually lower the heat to maintain a slow, steady rocking motion. Cook for time indicated in the recipe or cooking chart. When cooking is complete, remove pressure cooker from burner and allow it to cool.

Handy Tip: If the pressure regulator is allowed to rock vigorously, excess steam will escape; too much liquid will evaporate, and the food will burn.

10. Pressure should be reduced in accordance with the recipe or the cooking chart instructions. If the recipe or chart requires that the cooker cool naturally, then set the pressure cooker aside to cool until the pressure is completely reduced. If the recipe or chart requires that the cooker be cooled immediately, then cool the pressure cooker under running water, or place it in a pan of cold water until pressure is completely reduced. You will know this has occurred when the safety lock has dropped below the top of the handle.

11. After pressure has been completely reduced, remove the pressure regulator. **Always remove the regulator before opening the cover.**

12. To open the lid, turn it counter clockwise until the arrow on the body handle aligns with the “V” on the lid. Then lift the lid toward yourself to keep any steam away from you. If you have difficulty in rotating the lid, there is still some pressure in the unit. Do not force the lid off. Continue to cool the cooker until the safety lock has dropped, and the lid will turn easily.

13. This appliance cooks under pressure. Improper use may result in scalding injury. Make certain unit is properly closed before operation.

14. Do not open the pressure cooker until the unit has cooled and all internal pressure has been released. If the handles are difficult to push apart, this indicates that the cooker is still pressurized—do not force open. Any pressure in the cooker can be hazardous.

15. Food is ready to serve.

# HOW TO CLEAN YOUR PRESSURE COOKER

1. Your pressure cooker and all of its components are fully submersible for easy cleanup. Always remove the sealing ring to ensure thorough cleaning of the inside rim of the lid. The sealing ring should be washed with hot, sudsy water after each use. Remove the safety valve in the pressure cooker lid handle for cleaning. To remove the safety valve, turn the lid over and unscrew the safety valve, then remove the valve and spring and wash in warm sudsy water. Clean the hole in the lid handle with a small brush. After cleaning, reinsert the spring and metal shaft of the safety valve and thread gently into place. Be careful not to over-torque the valve.



2. The overpressure plug can also be removed for cleaning by pushing it out of its opening from the top of the cover. After cleaning, reinsert it by pushing the domed side of the plug into the opening from the underside of the lid, until the bottom edge is fully and evenly seated against the underside of the lid (Fig. H).



3. Clean the steam vent pipe with a small brush or pipe cleaner (Fig. I). To clean the vent pipe, unscrew the pressure regulator (Fig. J) on the top of the lid.

4. Minerals in water and foods may darken the inside of your pot. This discoloration will not affect the food cooked in the unit. Mineral stains can be removed by using a solution of water and cream of tartar. Use a tablespoon of cream of tartar for each quart of water. Dissolve the cream of tartar in the water and pour enough solution into the pot to fill completely. Heat to boil. Remove the pot from the heat and allow it to stand for two to three hours. Discard the contents. Scour thoroughly with a scrubbing pad, rinse, and dry.

5. The outside surface of your cooker may be cleaned with an aluminum cleaner if necessary. If washed in the dishwasher, discoloration may occur. If food residue adheres to the pressure cooker body, clean with a soft brush, or a fine kitchen cleanser.

6. When not in use, store your pressure cooker in a dry place with the lid inverted on the body. If the lid is locked on, the sealing ring could be damaged.

7. Avoid striking the rim of the pressure cooker body with metal cooking utensils, as this could cause nicks in the rim and prevent the pressure cooker lid from forming a proper seal.

8. If the handles loosen, tighten them with a screwdriver.

9. Leakage between the lid and body is usually caused by shrinkage of the sealing ring after prolonged use. Replace the sealing ring, and, whenever you do so, replace the overpressure plug as well. Do not apply cooking oil to sealing ring.



10. The formation of a small amount of moisture under the pressure regulator is normal when cooking first begins; however, it should stop when pressure begins to build and the overpressure plug and safety lock seals. If leakage continues, clean or replace the overpressure plug and safety lock assembly. If the pressure cooker still fails to seal, the gasket for the safety lock may be cracked.

## TIPS & HINTS

Your favorite recipes may be adjusted for use in your pressure cooker by following the cooking chart in this book for the food being prepared. Generally, you can reduce the cooking time for your recipe by 2/3, since pressure-cooking is much faster than other cooking methods. For example, if your ordinary cooking method requires 60 minutes, in the pressure cooker, cooking time will be reduced to 20 minutes. Because there is very little evaporation, the amount of liquid used should be decreased. Use about 8 oz. more liquid than desired in your finished dish. There are many different liquids that can be used in a pressure cooker; wine, beer, bouillon, fruit juices, and water all work excellently. Remember, there must always be water or some other liquid in the pressure cooker to produce the necessary amount of steam.

If a pressure cooker recipe or the cooking chart requires a cooking time of 0 minutes, cook the food only until the pressure regulator begins to rock. Remove the pressure cooker from the heat source and cool according to the recipe. For delicate foods such as custards, fresh vegetables, and serving-size pieces of meat, immediately cool the cooker. For roasts and stews, let the pressure drop of its own accord.

When cooking at high altitudes, the cooking time needs to be increased 5% for every 1,000 feet above the first 2,000 feet. Times should be adjusted as follows:

3,000ft .....	5%	5,000ft .....	15%	7,000ft .....	25%
4,000ft .....	10%	6,000ft .....	20%	8,000ft .....	30%

Because pressure-cooking times are increased at altitudes above 2,000 feet, additional cooking liquid will be needed.

## FREQUENTLY ASKED QUESTIONS

### **The lid is hard to open or close.**

The locking lid on your pressure cooker is designed to create an airtight seal. If you find that the lid becomes difficult to open or close, follow these suggestions:

**Hard to close:** Press the palm of your hand on the lid area directly opposite the lid handle while moving the lid handle to the closed position with your other hand. After braising meat or poultry, the cover may be difficult to close due to expansion of the pressure cooker body from heating. Allow the pressure cooker body to cool slightly and try again.

**Hard to open:** Generally, the only reason for the lid to be hard to open is that there is still pressure built up in the cooker. Allow the cooker to continue to cool until the lid is easily opened.

**Helpful Hint:** To help make the lid easier to open and close, a very light application of cooking oil may be applied to the bottom of the lugs on the pressure cooker body (Fig.J). Using a pastry brush, piece of cloth, or your fingertips, apply a small amount of oil to the lugs, making sure to remove any excess. Never apply cooking oil to the sealing ring.



### **There is more liquid in the pressure cooker than I want.**

Reduce over low heat to evaporate the excess liquid.

### **How do I prevent overcooking?**

Accurate timing is essential to preparing a great meal. Always remember to begin the cooking time when the pressure regulator has begun to gently rock. Using a kitchen timer will help to ensure that the cooking time is correct. Be sure to follow the recipe instructions for cooling the pressure cooker, as the food will continue to cook during the cool down period.

### **What if the food is not completely done after the recommended cooking time?**

Simply bring the cooker back up to pressure and cook the food a minute or two longer.

### **How do I know my pressure cooker is operating properly?**

The rocking pressure regulator provides both a visual and audible indicator that your cooker is functioning correctly.

### **What kind of range is best for pressure-cooking?**

Your aluminum pressure cooker is very energy-efficient and will work on all stoves and range tops with the exception of induction ranges.

### **When cooking first begins, is it normal for steam to escape and moisture to form on the cover and between the handles?**

Yes. However, if steam continues to vent around the handles and/or lid, the lid may not be fully locked onto the body.

### **The safety lock rises partially and then drops back down when cooking first begins?**

The safety lock will move up and down slightly when cooking first begins. The safety lock should remain in the up position once the cooker has sealed. If the safety lock continues to move up and down or rises only partially, tap it lightly with the tip of a knife. If safety lock does not rise and seal, check the following:

1. The range is not hot enough.
2. The cooker is not fully sealed.
3. There is not enough liquid to form steam.
4. The gasket for the safety lock needs to be replaced.

# COOKING TIMES

Processing times at 15 pounds pressure, as given in this chart, apply only to altitudes up to 3,000 feet. For higher altitudes please see Tips & Hints section. Do not fill the unit over 2/3 full. When cooking foods that expand during cooking, such as rice or dry vegetables, do not fill over 1/2 full. Overfilling may cause a risk of clogging the vent pipe and developing excess pressure.

## MEATS & POULTRY

It is best to brown or sear meats and poultry prior to adding liquid for the pressure-cooking process. This will help to lock in flavor. Use a small bit of cooking oil to prevent the foods from sticking.

All roasts listed below refer to a 3 lb. size. Roasts do not require cooling the cooker after the prescribed cooking time. However, on cut pieces of meat or poultry, always cool the cooker to avoid overcooking.

Meat or Poultry	Cooking Time in Minutes	Liquid Added in Cups
Beef Chuck Roast	35	1 1/2
Beef Stew or Short Ribs	25	2
Game Fowl (pieces)	8	1
Game Meat	30	1 1/2
Lamb Chops (1/2" thick)	5	1/2
Leg of Lamb	35-40	1 1/2
Pork Chops (1/2" thick)	5	1
Pork Roast	55	3
Poultry (pieces)	8	1
Poultry (whole)	15	1 1/2
Veal Roast	40	2
Veal Chops (1/2" thick)	5	1/2

## FRESH VEGETABLES

When using the following cooking times, choose the lowest number for a crisper consistency, and the highest number for softer vegetables. Always cool the cooker, as described on page 7, to avoid overcooking.

Vegetable	Cooking Time in Minutes	Liquid Added in Cups
Artichokes	12	1
Asparagus (1" pieces)	0-2	1/2
Beans, Lima (shelled)	1-2	1/2
Beans, Green	1-3	1/2
Beets, Whole (2 1/2" diameter)	12-14	1 1/2
Broccoli - Medium spears	0-2	1/2
Brussels Sprouts	1-3	1/2
Cabbage (2" wedges)	1-3	1
Carrots (whole)	4-7	1
Carrots (sliced)	1-2	1/2
Cauliflower (whole, 6" diameter)	2-5	1
Corn-on-the-Cob	2-3	1/2
Greens (Beet, Spinach, Swiss Chard, Turnip)	0-3	1/2
Okra	1-3	1/2
Peas, Shelled	0-2	1/2
Potatoes (whole, 2 1/2" diameter)	15	1 1/2
Squash (cubed or sliced, 1" thick)	10-12	1 1/2
Sweet Potatoes (whole)	10	1
Tomatoes for Sauces	5	1/2
Turnips (cubed or sliced, 1" thick)	3	1/2

## DRIED VEGETABLES

All of the items below MUST be presoaked to avoid foaming during the cooking process. All cooking times relate to two cups of the dried vegetables. To presoak, add 1-2 tablespoons cooking oil, one tablespoon of salt, and cover completely with water. Soak overnight, or for at least eight hours. Drain, and re-cover with clear water.  
DO NOT FILL OVER THE PRESSURE COOKER'S CAPACITY.

Dried Vegetable	Cooking Time in Minutes
Black Beans	35
Black-eyed Peas	20
Great Northern or Navy Beans	30
Kidney Beans	25
Lentils	20
Lima Beans	25
Pinto Beans	25

## SEAFOOD

All of the following seafood items require one cup of liquid for pressure-cooking. Always cool the cooker, as described on page 8, to avoid overcooking.

Seafood	Cooking Time in Minutes
Crab Legs	2
Fish (whole)	6
Fish (steaks or fillet)	2
Lobster Tail (6-8 oz.)	10-12
Salmon (whole)	6
Salmon (steaks or fillet)	2
Shrimp (medium)	2

## CEREALS

For rice and corn meal, ingredients MUST be added to boiling water prior to placing the lid on the pressure cooker. Stir well. All of the items below are based on 1 cup. If doubling the recipe, also double the liquid required.  
DO NOT FILL OVER THE PRESSURE COOKER'S CAPACITY.

Cereal	Cooking Time in Minutes	Liquid Added in Cups
Corn Meal (fine, polenta)	5	3
Brown Rice	18	1 3/4
White Rice	6	1 1/2
Wild Rice	25	3



tabletops<sup>™</sup>  
unlimited<sup>™</sup>  
*since 1983*

CASA MARIA name and logo are registered trademarks of Tabletops Unlimited®

© 2013 TABLETOPS UNLIMITED ALL RIGHTS RESERVED.

23000 South Avalon Blvd. Carson, CA 90745  
visit [www.ttucorp.com](http://www.ttucorp.com) [www.ttustore.com](http://www.ttustore.com)

Be social check us out   

Made and Printed in China