

**EXERPEUTIC**  
THERAPEUTIC FITNESS

# Magnetic Treadmill

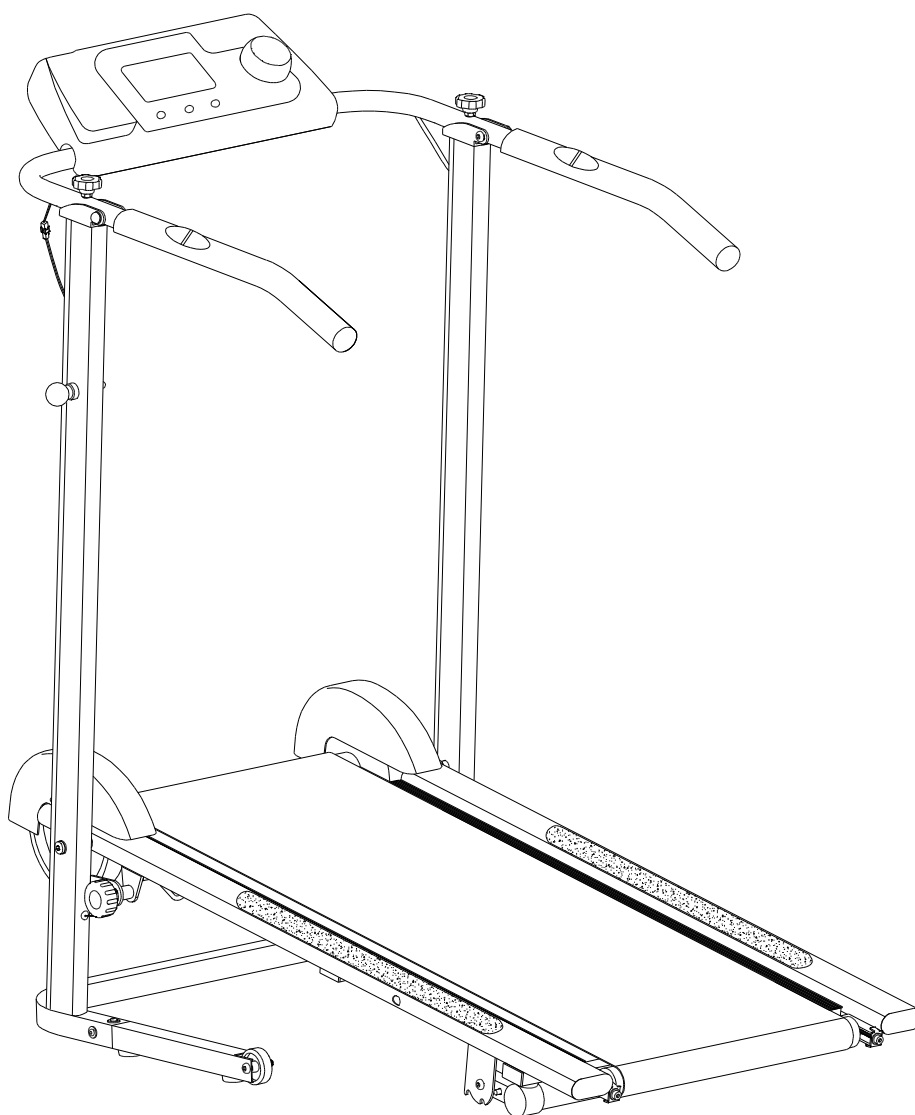

**OWNER'S MANUAL**

Item# 4010

## TABLE OF CONTENTS

SERVICE .....	2
IMPORTANT LABELS .....	3
PRODUCT SAFETY .....	4
PARTS DRAWING .....	5
PARTS LIST .....	6
PARTS LIST & TOOLS .....	7
ASSEMBLY .....	8
COMPUTER .....	11
STORAGE .....	12
ADJUSTMENTS .....	13
LUBRICATION .....	15
TROUBLE SHOOTING & MAINTENANCE .....	16
WARM UP .....	17
WARRANTY .....	18
FAX FORM .....	19

## SERVICE

### **IMPORTANT: FOR NORTH AMERICA ONLY**

**To request product service and order replacement parts, please call our customer service department at:  
1-844-641-7921**

Monday through Friday, 8:00 AM-5:00 PM Pacific Standard Time,  
or email us at: [service@paradigmhw.com](mailto:service@paradigmhw.com)  
Please visit our website at [www.paradigmhw.com](http://www.paradigmhw.com).

**Please have the following information ready when requesting for service:**

- Your name
- Phone number
- Model number
- Serial number
- Part number
- Proof of Purchase

**\*Before returning this product to the store please contact customer service at the contact number.**

Paradigm Health & Wellness, Inc.  
1189 Jellick Ave, City of Industry, CA 91748, USA

## IMPORTANT LABELS

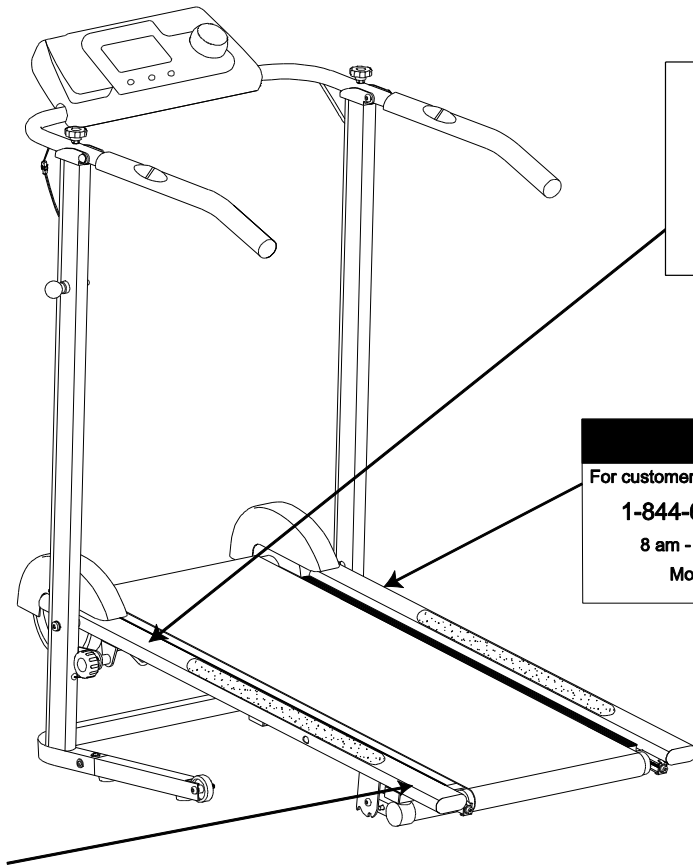

<b>EXERPEUTIC</b>	
For customer assistance call:	Pour le service à la clientèle composer le:
<b>1-844-641-7921</b>	<b>1-844-641-7921</b>
8 am - 5 pm PST Mon - Fri	Du lundi au vendredi 8:00 h - 17 h (HNP)

<b>⚠ WARNING</b>
<b>Maximum weight capacity is 300 lbs.</b>
<b>⚠ AVERTISSEMENT</b>
<b>Le poids maximum pour ce produit est 136 kgs.</b>

## PRODUCT SAFETY

**Basic precautions should always be followed, including the following safety instructions when using this magnetic treadmill: Read all instructions before using this magnetic treadmill.**

1. Check every part of the equipment before exercise. If there is any defective component, replace it immediately; keep the equipment out of use until repair.
2. Make sure all parts, bolts and nuts are well assembled and locked before exercise.
3. Never insert any object into any opening.
4. Never operate this magnetic treadmill if it is not working properly. If it has been dropped or damaged, or been exposed to water, do not use and consult an *Authorized Service Representative at 1-844-641-7921*.
5. Do not attempt any maintenance or adjustments other than those described in this manual. Should any problems arise, discontinue use and consult an *Authorized Service Representative*.
6. Wear comfortable and suitable clothing when using the treadmill. Do not use the treadmill barefoot, in only socks or in sandals, always wear athletic shoes. Never wear loose clothing because it could run the risk of getting caught in the treadmill.
7. Keep children and pets away from the equipment while in use.
8. Do not use the treadmill outdoors. This magnetic treadmill is for household use only.
9. Only **one** person should be on the treadmill while in use.
10. Keep the magnetic treadmill on a solid, level surface with the minimum safety area clearance of 78.7" x 118" of the magnetic treadmill. Be sure the area around the treadmill remains clear during use and has adequate clearance.
11. Hold the handlebar with your hands when starting or stopping exercise and increasing or decreasing the speed.
12. If feeling chest pains, nausea, dizziness, or short of breath, you should stop exercising immediately and consult your physician before continuing.
13. The maximum weight capacity for this product is 300 lbs.

**WARNING:** Before beginning any exercise program consult your physician. This is especially important for the persons who are over 35 years old or who have pre-existing health problems. Read all instructions before using any fitness equipment.

**CAUTION:** Read all instructions carefully before operating this product. Retain this Owner's Manual for future reference.

# PART DRAWING

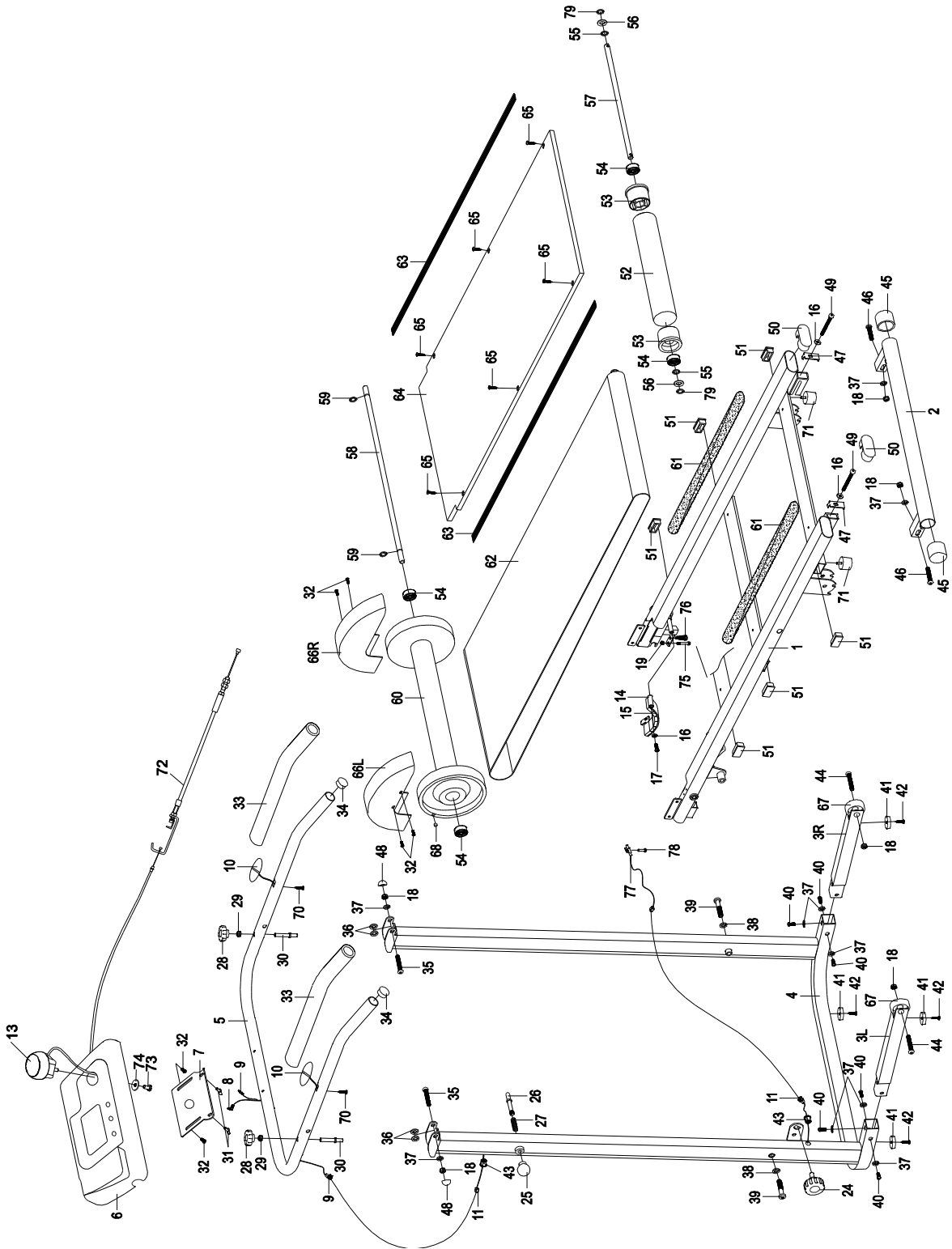

## PART LIST

No.	Description	Qty	No.	Description	Qty
001	Main Frame	1	034	Handlebar End Cap	2
002	Incline Adjuster	1	035	Bolt M8x50	2
003L	Left Stabilizer Tube	1	036	Nylon Washer Ø20xØ9.5x2.5	4
003R	Right Stabilizer Tube	1	037	Washer Ø16xØ8.5x1.5	10
004	Stabilizer	1	038	Washer Ø20xØ10.5x1.5	2
005	Handlebar	1	039	Bolt M10x55	2
006	Computer	1	040	Bolt M8x15	6
007	Computer Support Plate	1	041	Rubber Pad Ø32x8.8	4
008	Hand Pulse Sensor Extension Wire	1	042	Bolt M4x20	6
009	Extension Sensor Wire II [Short]	1	043	Wire Plug Ø12.5	2
010	Hand Pulse Sensor with Wire	2	044	Bolt M8x43	2
011	Extension Sensor Wire I [Long]	1	045	Incline Adjuster Round Cap Ø25	2
013	Tension Control Knob	1	046	Bolt M8x47	2
014	Magnet Bracket	1	047	Rear Roller Adjustment Bolt Plate	2
015	Magnet	5	048	Cap 13#	2
016	Washer Ø13xØ6.5x1.5	3	049	Rear Roller Adjustment Bolt M6x80	2
017	Bolt M6x10	1	050	Elliptic End Cap 30x70	2
018	Nylon Nut M8	6	051	Rectangular End Cap 20x40	6
019	Nut M6	1	052	Rear Roller Ø42	1
024	Round Knob M10x25	1	053	Bearing Cap Ø42	2
025	Ball Knob Ø30xM8	1	054	Bearing 6201	4
026	Spring Knob Pin	1	055	Washer Ø16xØ12.3	2
027	Spring Ø12x1x37	1	056	Big Washer Ø24xØ13.2x2.0	2
028	Handlebar Knob Ø40xM8	2	057	Rear Roller Axle Ø12x469	1
029	Nut M8	2	058	Front Roller Axle Ø12x573	1
030	Handlebar Knob Pin Ø12xM8x58	2	059	Clip	2
031	Computer Knob M5x15	2	060	Front Roller Ø42x520	1
032	Bolt M5x10	6	061	Anti-slip Pad	2
033	Handlebar Foam Grip	2	062	Running Belt	1

## PART LIST & TOOL

No.	Description	Qty	No.	Description	Qty
063	Side Rail	2	072	Tension Cable	1
064	Running Deck	1	073	Bolt M5x10	1
065	Phillips Self Drilling Screw	6	074	Big Washer Ø20xØ6x1.5	1
066L	Left Protective Cover	1	075	Bolt M6x35	1
066R	Right Protective Cover	1	076	Spring Ø112xØ20x46	1
067	Transport Wheel	2	077	Sensor with Wire	1
068	Small Magnet	1	078	Screw ST4.8x10	1
070	Screw ST3.8x20	2	079	Plastic Washer Ø25xØ13x2	2
071	Rubber Pad Ø37x29	2			

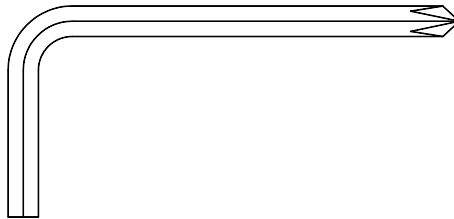

Allen Wrench with Phillips Screwdriver 5#  
1 PC

## ASSEMBLY

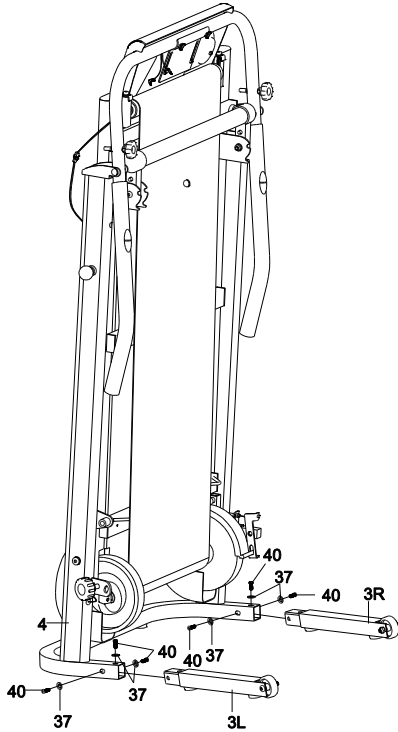

### Tool:

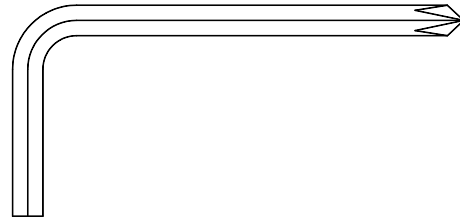

*Allen Wrench with Phillips Screwdriver 5#*

### Step 1

Place the magnetic treadmill in the upright position.

Remove six Washers (37) and six Bolts (40) from the Left/Right Stabilizer Tubes (3L, 3R). Remove bolts with the 5# Allen Wrench with Phillips Screwdriver provided.

Install both Left/Right Stabilizer Tubes (3L, 3R) to the Stabilizer (4) by inserting both Left/Right Stabilizer Tubes (3L, 3R) into the Stabilizer (4), using six Washers (37) and six Bolts (40) that were removed. Tighten bolts with the 5# Allen Wrench with Phillips Screwdriver provided.

## ASSEMBLY

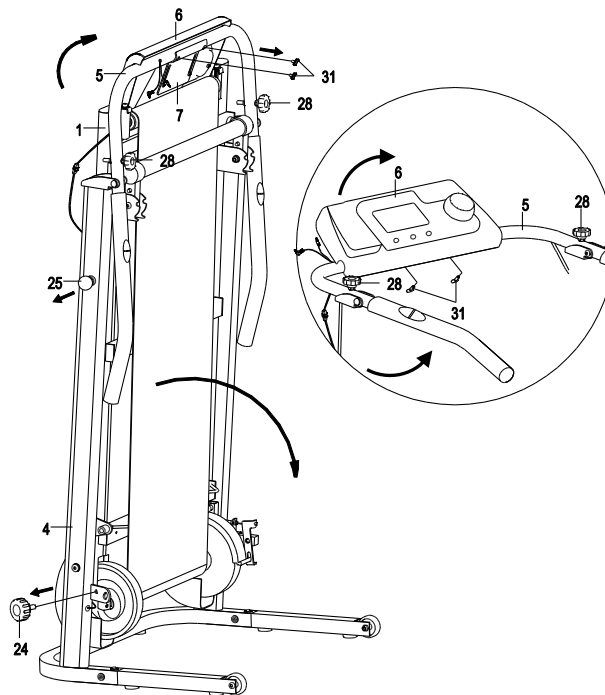

### Step 2

Remove the Round Knob (24) from the Stabilizer (4). Place one hand on the rear end of Main Frame (1) and use the other hand to pull out the Ball Knob (25). Lower the Main Frame (1) down onto the floor.

**TO PREVENT INJURY PLEASE MAKE SURE YOU HAVE A FIRM HOLD WHEN SETTING DOWN THE DECK.**

Remove two Computer Knobs (31) from the Computer Support Plate (7). Remove two Handlebar Knobs (28) from the Handlebar (5) and then lift the Handlebar (5) all the way up.

Tighten the Handlebar (5) onto the Stabilizer (4) with two Handlebar Knobs (28) that were removed.

Turn the Computer (6) upwards and adjust the angle of Computer (6) to the desired position. Hold the Computer (6) and align computer knob holes.

Tighten the Computer (6) onto the Handlebar (5) with two Computer Knobs (31) that were removed.

## ASSEMBLY

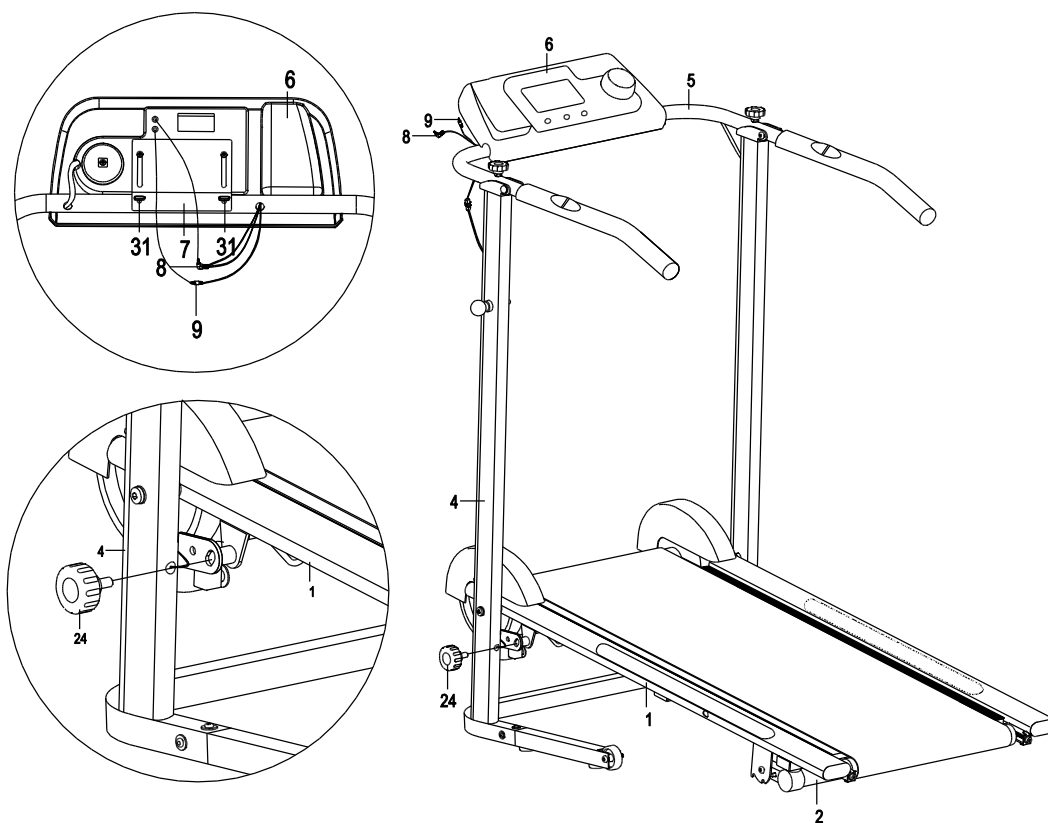

### Step 3

Install Round Knob (24) to the bigger hole on the Stabilizer (4) and Main Frame (1) by turning it in a clockwise direction to lock the Main Frame (1) in place.

**Note:** Securely tighten Round Knob (24) so that the treadmill is sturdy.

Plug the Hand Pulse Sensor Extension Wire (8) from the Handlebar (5) into PULSE receptacle on the back of Computer (6).

Plug the Extension Sensor Wire II (9) from the Handlebar (5) into SENSOR INPUT receptacle on the back of Computer (6).

## COMPUTER

### Specifications:

TIME -----00:00-99:59 MIN: SEC  
DISTANCE -----0.00-9999 MI  
CALORIES -----0.0-9999 CAL  
ODOMETER ----- 0-9999 MI  
PULSE -----40-240 BEATS/MIN



### Button functions:

**MODE:** Display function selection.

**SET:** To set goal values as exercise target.

**RESET:** To clear goal values.

### Display functions:

**SCAN** Automatically scans through each display mode at 6-second intervals.

**TIME** Displays Times.

**SPEED** Displays the current speed.

**DISTANCE** Displays distance of exercise sessions.

**CALORIES** Displays calories burned during exercises.

**ODOMETER** Displays accumulative distance from combined exercise sessions.

**PULSE** Display the BPM (Beats per Minutes).

### Set a goal value:

You can set an exercise goal, the value will be counted down for the value you set.

Press MODE to select a value you'd like to set.

Press SET to set the value, then start your exercise.

### How to install the batteries:

1. Remove the battery cover at the rear of computer.
2. Place two "SIZE-AA" batteries into the battery housing.
3. Insure batteries are correctly positioned and battery springs are in proper contact with batteries.
4. Re-install the battery cover.
5. If the display is illegible or only partial legible, remove batteries and wait 15 seconds before reinstalling.

## STORAGE

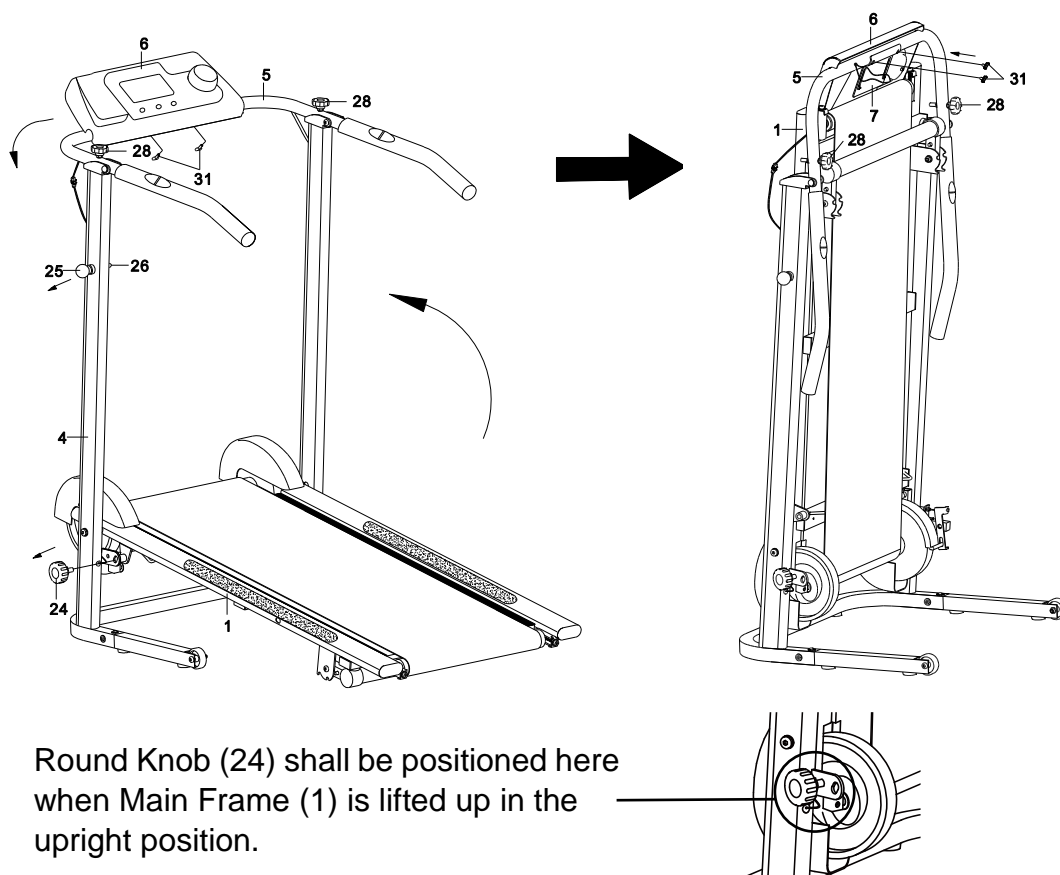

Round Knob (24) shall be positioned here when Main Frame (1) is lifted up in the upright position.

Remove Round Knob (24) from the Stabilizer (4) and Main Frame (1). Hold the rear end of the Main Frame (1) by one hand and use the other hand to pull out the Ball Knob (25). Lift the Main Frame (1) up and align spring knob pin hole. Release the Ball Knob (25) until the Spring Knob Pin (26) pop into the hole on the Main Frame (1) to lock the Main Frame (1) in place. **CAUTION:** Failure to secure the Main Frame (1) with the Spring Knob Pin (26) may cause the treadmill accidental fall and cause bodily injury.

Install the Round Knob (24) onto the Main Frame (1).

Remove two Handlebar Knobs (28) from the Handlebar (5) and then push the Handlebar (5) all the way down.

Install two Handlebar Knobs (28) back onto the Handlebar (5) to lock the Handlebar (5) in place.

Remove two Computer Knobs (31) from the Computer Support Plate (7). Turn the Computer (6) downwards and align computer knob holes.

Tighten the Computer (6) onto the Handlebar (5) with two Computer Knobs (31) that were removed.

## ADJUSTMENTS

### Adjusting the Tension Control Knob

To increase the load, turn the tension control knob in a clockwise direction. To decrease the load, turn the tension control knob in a counterclockwise direction.

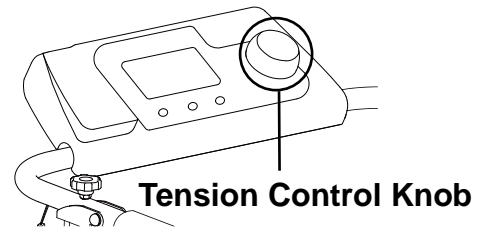

### Adjusting the Incline

There are 3 incline angles (**A: 8%**, **B: 10%**, **C: 12%**) that the incline adjuster can be set to. Place one hand on the rear end of the main frame, then lift the rear end of the main frame up and use your other hand to adjust the Incline adjuster to the desired position.

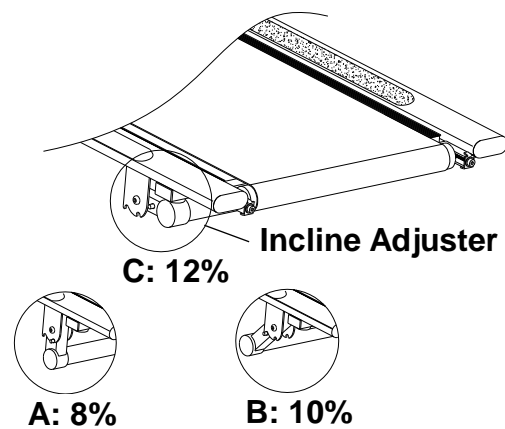

### About the Running Belt Keeping the Belt aligned

This belt is 16 inches wide. It is recommended that the user's footsteps stay on the central 12 inches area. This will prevent the belt from shifting off the center. Note: Continuously stepping on the edge of the Belt will cause the Belt to shift to either side of the bed.

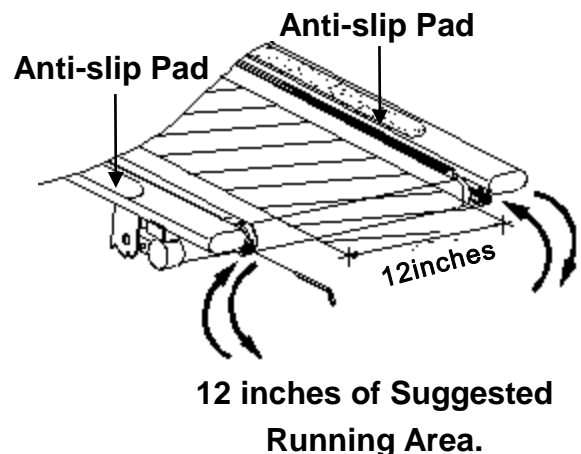

## ADJUSTMENTS

### Adjusting the Running Belt

1. The running belt is initially set and adjusted at the factory. However it may come loose during transportation and/or during use. After prolonged use, the belt will begin to stretch out.
2. If the running belt begins to shift to either left or right side, the user can stand on the Anti-slip Pads and hold the handlebar with both hands. Then use your right or left foot to run on the side of the running belt that is opposite to the direction of the slip.
3. If the belt begins to slip to the left use your right foot on the right side. You should see the belt start to correct itself by moving back towards the center.
4. However, if the running belt is still shifting away from center, use the 5# Allen Wrench provided and turn the left or right Rear Roller Adjustment Bolt 1/2 turn in a clockwise direction (turn the same side bolt that matches the direction of the slip).

Then try running on the center of the running belt again. If the running belt is still shifting away from center, turn the same Rear Adjustment Bolt another 1/4 turn in the clockwise direction. You should see the belt start to correct itself by moving back towards the center.

Repeat this procedure until the running belt is centered.

If the running belt is slipping during use, then use the 5# Allen Wrench provided and turn both the left and right rear roller adjustment bolts 1/4 turn in the clockwise direction. You should now run on the running belt to determine if the running belt is still slipping. Repeating the above procedure until the running belt is not slipping.

## LUBRICATION

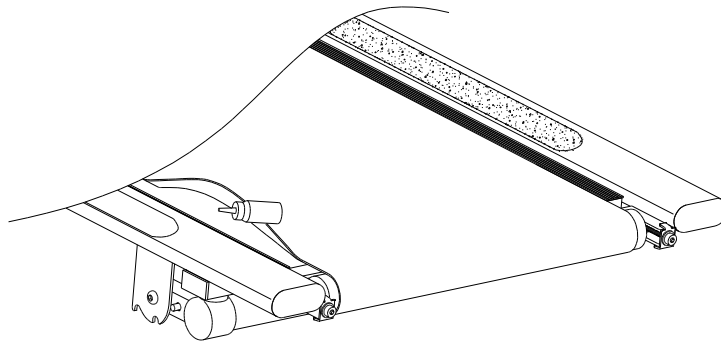

The treadmill has already been spread with "Silicone Oil" in advance before leaving the manufacturing plant. Silicone oil is without volatility and has gradually permeated through the running belt. There will be no need to re-spread the oil in normal circumstances. "Silicone Oil" may be re-spread once the resistance has been increased and the running belt starts rubbing against the running deck. To hold open the running belt from two sides, apply the silicone oil with an even motion on the center of the running deck. Allow the silicone oil to 'set' for one minute before using the magnetic treadmill.

**Attention:** Only use "Silicone Oil" lubricants for this equipment. **In addition, do not add any other oil ingredient; otherwise the magnetic treadmill will be damaged. Do not over-lubricate the running deck. Excess lubricant should be wiped off with a clean towel.**

### TROUBLE SHOOTING

**PROBLEM:** Treadmill running belt slips or is not centered on rear roller.

**SOLUTION:** Refer to “Adjusting the Running Belt” section on page 14.

**PROBLEM:** Computer not working correctly

**SOLUTION:** Check to make sure the computer wires are connected securely.

**SOLUTION:** Check the batteries are correctly positioned and battery springs are proper contact with batteries.

**SOLUTION:** Make sure the batteries are not dead.

**PROBLEM:** There is no heart rate reading or heart rate reading or is erratic / inconsistent.

**SOLUTION:** Make sure that the wire connections for the hand pulse sensors are secure.

**SOLUTION:** To ensure the pulse readout is more precise, please always hold on to the handlebar grip sensors with two hands instead of just with one hand only when you try to test your heart rate figures.

**SOLUTION:** Gripping the hand pulse sensors too tight. Try to maintain moderate pressure while holding onto the hand pulse sensors.

**PROBLEM:** The magnetic treadmill makes a squeaking noise when in use.

**SOLUTION:** The bolts may be loose on the magnetic treadmill, please inspect the bolts and tighten the loose ones.

### MAINTENANCE

#### Cleaning

The magnetic treadmill can be cleaned with a soft cloth and mild detergent. Do not use abrasives or solvents on plastic parts. Please wipe your perspiration off the magnetic treadmill after each use. Be careful not get excessive moisture on the computer display panel as this might cause an electrical hazard or electronics to fail. Please keep the magnetic treadmill, specially, the computer console, out of direct sunlight to prevent screen damage. Please inspect all assembly bolts on the machine for proper tightness every week.

#### Storage

Store the magnetic treadmill in a clean and dry environment away from children.

## WARM UP

### Quadriceps Stretch

With one hand against a wall for balance, reach behind you and pull your right foot up. Bring your heel as close to your buttocks as possible. Hold for 15 counts and repeat with left foot up.

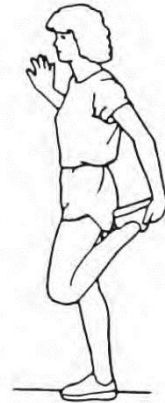

### Inner Thigh Stretch

Sit with the soles of your feet together with your knees pointing outward. Pull your feet as close into your groin as possible.

Gently push your knees towards the floor. Hold for 10 counts.

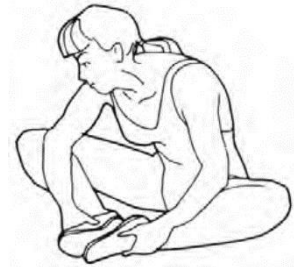

### Toe Touches

Slowly bend forward from your waist, letting your back and shoulders relax as you stretch toward your toes. Reach down as far as you can and hold for 15 counts.

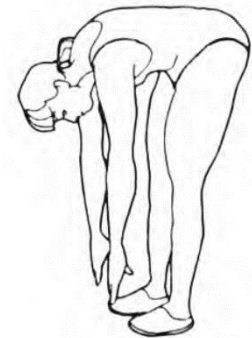

### Hamstring Stretches

Sit with your right leg extended. Rest the sole of your left foot against your right inner thigh. Stretch toward your toe as far as possible. Hold for 15 counts. Relax and then repeat with left leg extended.

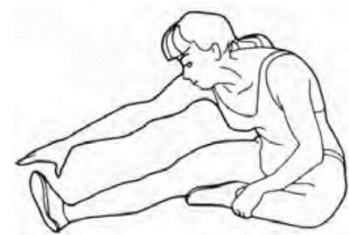

## WARRANTY

Paradigm Health & Wellness, Inc. warrants to the original purchaser that this product is free from defects in material and workmanship when used for the purpose intended, under the conditions that it has been installed and operated in according to Paradigm Health & Wellness, Inc.'s Owner's Manual. Paradigm Health & Wellness, Inc.'s obligation under this warranty is limited to replacing free of charge, any parts which may prove to be defective under normal home use. This warranty does not include any damage caused by improper operation, misuse or commercial application. From the date of purchase, the product is warranted to be free from defects for 3 (three) year. All parts and workmanship, including upholstery, foam, ball bearings, pulleys, cables, shocks, all tension mechanisms, wheels, pedals and hardware are to be free from defects for 90 days. This warranty is offered only to the original owner and is not transferable. Proof of purchase is required. This warranty is offered only to the original owner and is not transferable.

### **Ordering Replacement Parts**

Replacement parts can be ordered by calling or emailing our customer service department

**service@paradigmhw.com**

**1-844-641-7921**

Monday through Friday, 8:00 AM - 5:00 PM (PST).

When ordering replacement parts please have the following information ready:

- 1. Owner's Manual**
- 2. Model Number**
- 3. Description of Parts**
- 4. Part Number**
- 5. Date of Purchase**

**FAX FORM**

**Paradigm Health & Wellness, Inc.**

**PARTS REQUEST FAX FORM**

Please fax this form to (1-626-810-2166)

**OR YOU CAN EMAIL CUSTOMER SERVICE REQUESTS TO  
service@paradigmhw.com**

NAME: \_\_\_\_\_

ADDRESS: \_\_\_\_\_

CITY \_\_\_\_\_ STATE \_\_\_\_\_ ZIP \_\_\_\_\_

TELEPHONE: (Day) \_\_\_\_\_

(Night) \_\_\_\_\_

(Email Address) \_\_\_\_\_

SERIAL#: \_\_\_\_\_

MODEL#: \_\_\_\_\_

PURCHASE DATE: \_\_\_\_\_

PURCHASE FROM: \_\_\_\_\_

PART #	DESCRIPTION	QTY

***“YOUR ORDER WILL BE PROCESSED WITHIN 3 BUSINESS DAYS”***

<b>OFFICIAL USE ONLY</b>
SHIP DATE: _____
TRK #: _____
BACK ORDER: _____