

**EXERPEUTIC**  
THERAPEUTIC FITNESS

## TRAINING CYCLE

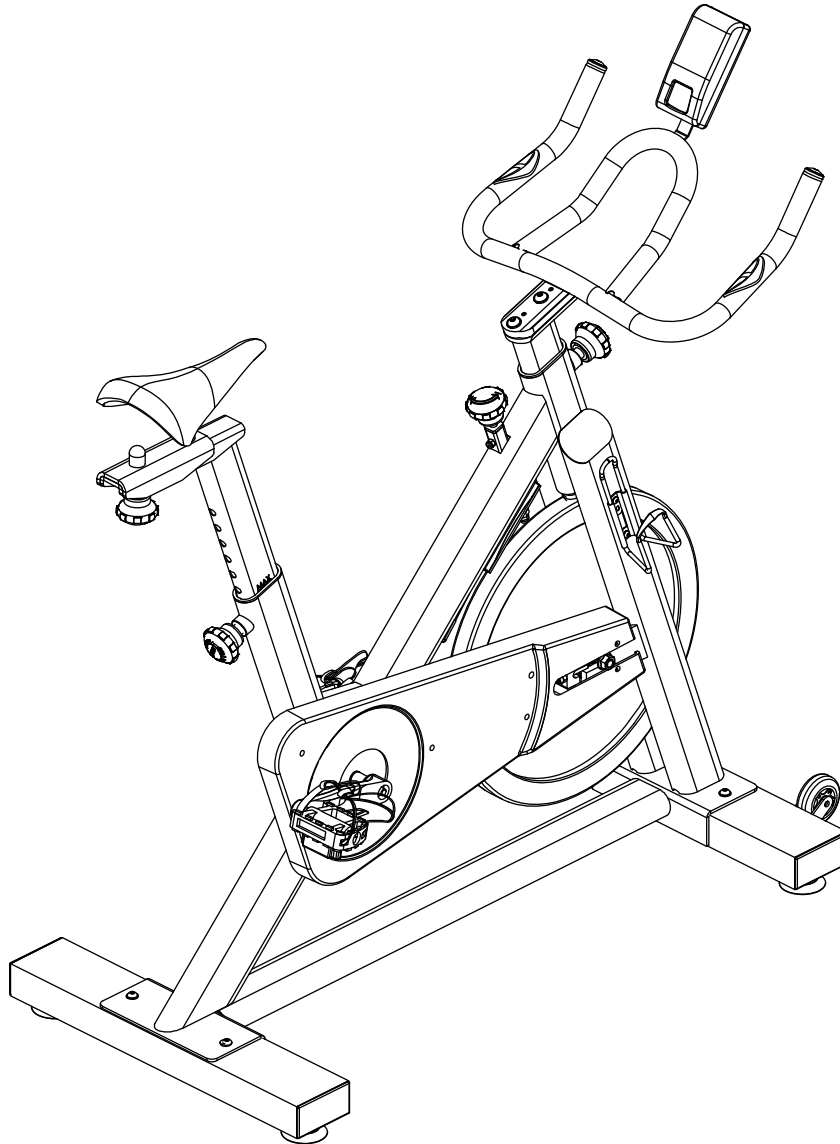

**IMPORTANT:** Read all instructions carefully before using this product.  
Retain this owner's manual for future reference.  
The specifications of this product may vary from this photo, subject to  
change without notice.

V1.0-061114

**OWNER'S MANUAL**

Item #4200

## TABLE OF CONTENTS

SERVICE .....	2
LABEL PLACEMENT .....	3
PRODUCT SAFETY .....	4
OVERVIEW DRAWING .....	5
PARTS LIST .....	6
HARDWARE PACKING LIST & TOOLS .....	7
ASSEMBLY .....	8
ADJUSTMENTS .....	13
COMPUTER .....	16
TROUBLE SHOOTING & MAINTENANCE .....	20
WARM UP .....	21
WARRANTY .....	22
FAX FORM .....	23

## SERVICE

### **IMPORTANT: FOR NORTH AMERICA ONLY**

**To request product service and order replacement parts, please call our customer service department at:  
1-844-641-7921**

Monday through Friday, 8:00 AM-5:00 PM Pacific Standard Time,  
or email us at: [service@paradigmhw.com](mailto:service@paradigmhw.com)  
Please visit our website at [www.paradigmhw.com](http://www.paradigmhw.com).

**Please have the following information ready when requesting for service:**

- Your name
- Phone number
- Model number
- Serial number
- Part number
- Proof of Purchase

**\*Before returning this product to the store please contact customer service at the contact number.**

Paradigm Health & Wellness, Inc.  
1189 Jellick Ave.  
City of Industry, CA 91748, USA

# LABEL PLACEMENT

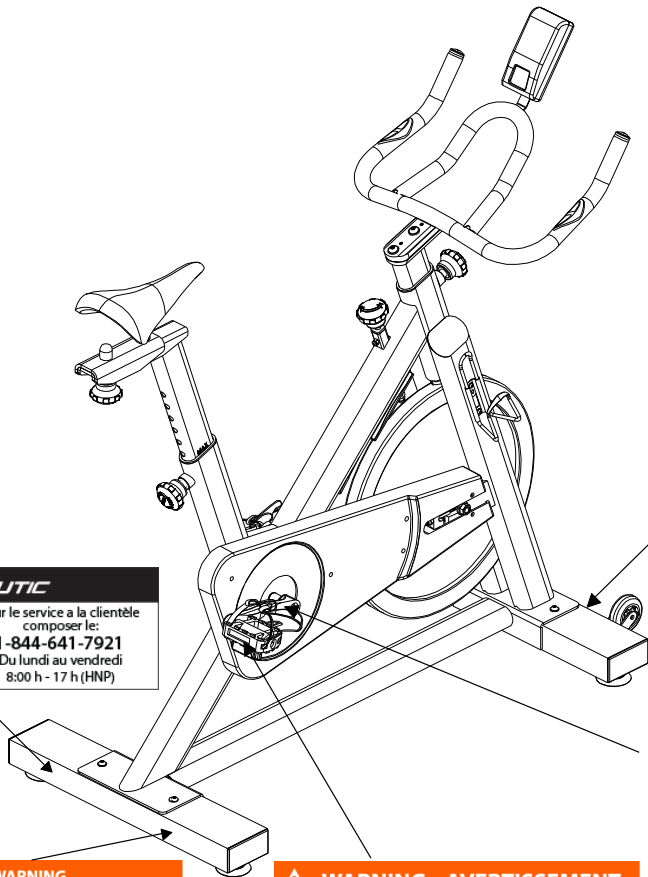

**EXERPELTIC**  
 For customer assistance call:  
**1-844-641-7921**  
 8 am - 5 pm PST  
 Mon - Fri

Pour le service à la clientèle  
 composer le:  
**1-844-641-7921**  
 Du lundi au vendredi  
 8:00 h - 17 h (HNP)

  
**11416942000001**  
 Serial number/Numéro de série:  
**MADE IN CHINA/FABRIQUE EN CHINE**

**⚠ WARNING**  
 Maximum weight capacity is 275 lbs.  
**⚠ AVERTISSEMENT**  
 Le poids maximum pour ce produit  
 est 125 kgs.

**⚠ WARNING AVERTISSEMENT**  
 Sharp pedal edges  
 Des bords coupants de la pédale

**⚠ CAUTION (Model 4200)**  
 The Crank will be damaged if the  
 Right or Left Bolts are not  
 tightened as per below instructions!

- Tighten Right Bolt (6R) Into the  
 Right Crank Clockwise 
- Tighten Left Bolt (6L) Into the  
 Left Crank Counter Clockwise 

**⚠ ATTENTION (N° 4200)**  
 La manivelle pourrait être endommagée  
 si les boulons droit ou gauche ne sont pas  
 serrés, selon les instructions ci-dessous.

- Serrez le boulon droit (6R) dans la  
 manivelle droite dans le sens horaire 
- Serrez le boulon gauche (6L) dans  
 la manivelle gauche dans le sens  
 antihoraire 

## PRODUCT SAFETY

**Basic precautions should always be followed, including the following safety instructions when using this equipment. Read all instructions before using this equipment.**

1. Read all the instructions in this manual and do warm up exercises before using this equipment.
2. Before exercise, in order to avoid injuring your muscles, warm-up exercise for every muscle group is highly recommended. Please refer to the Warm Up pages for pre and post workout.
3. Please make sure all components are not damaged and in working order before use. This equipment should be placed on a flat surface while in use. Using a mat or other material on the ground is recommended.
4. Please wear proper clothes and shoes when using this equipment; do not wear clothes that get caught in any part of the equipment.
5. Do not attempt any maintenance or adjustments other than those described in this manual. Should any problems arise, discontinue use and consult an *Authorized Service Representative*.
6. Keep Dry - do not operate in wet or moist condition.
7. Always hold on to the handlebar while using the training bike.
8. To dismount, reduce pedaling speed gradually before you stop.
9. Do not use the equipment outdoors.
10. This equipment is for household use only.
11. Only one person should be on the equipment while in use.
12. Keep children and pets away from the product while in use. This machine is designed for adults only. This product requires a minimum of 6 feet of space for safe operation.
13. If you feel any chest pains, nausea, dizziness, or short of breath, you should stop exercising immediately and consult your physician before continuing.
14. The maximum weight capacity for this product is 275 lbs/125 kgs.

**WARNING:** Before beginning any exercise program consult your physician. This is especially important for the people who are over 35 years old or who have pre-existing health problems. Read all instructions before using any fitness equipment.

**CAUTION:** Read all instructions carefully before operating this product. Retain this Owner's Manual for future reference.

# OVERVIEW DRAWING

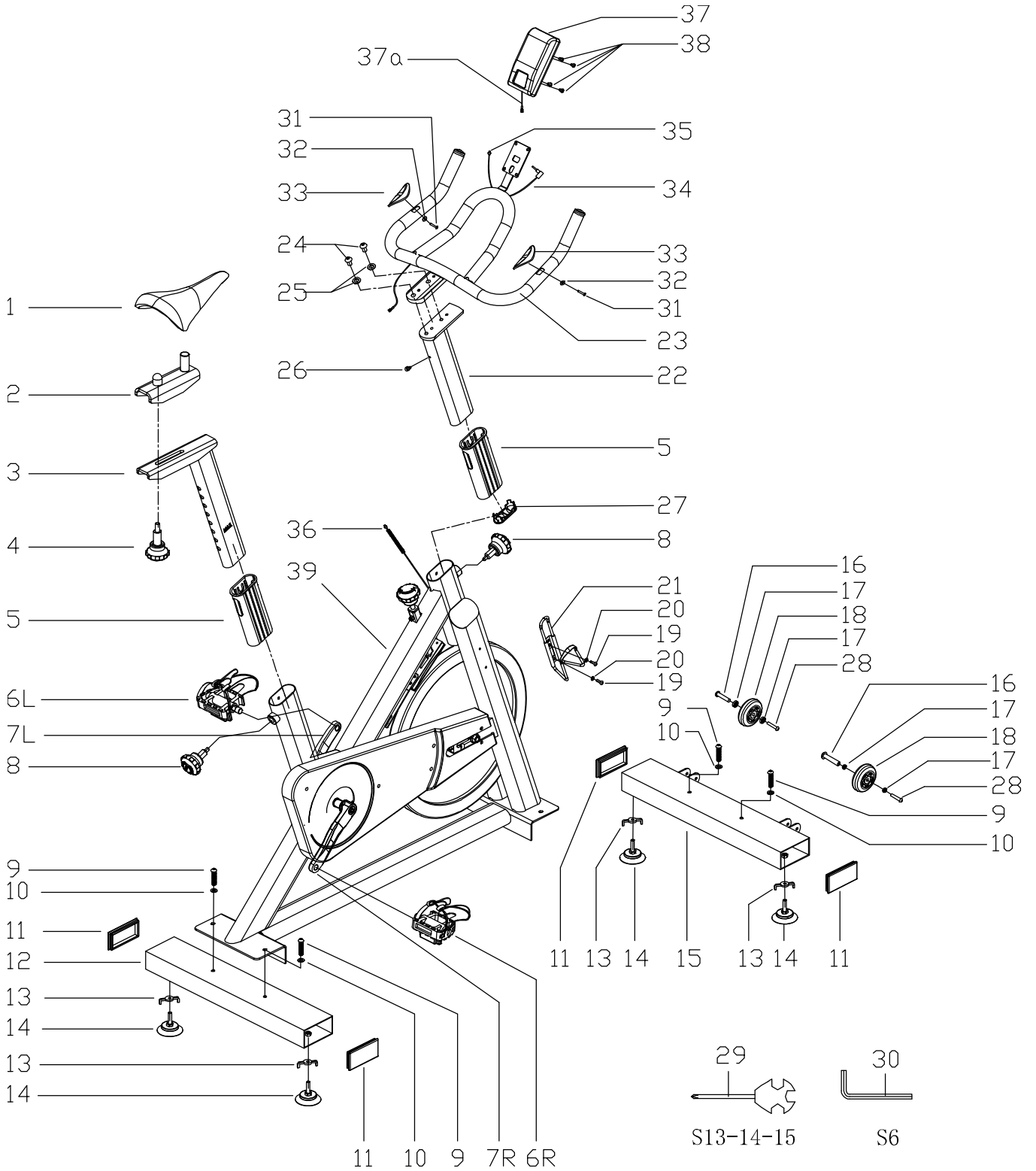

## PARTS LIST

No.	Description	Qty	No.	Description	Qty
001	Seat	1	021	Water Bottle Holder	1
002	Seat Bracket	1	022	Handlebar Post	1
003	Seat Post	1	023	Handlebar	1
004	Round Knob M10*22*Φ19*35	1	024	Hexagon Socket Pan Head Cap Screw M10*25*S6	2
005	Oval Bushing PT80*40*PT70*30*L175	2	025	Flat Washer d10*φ20*1.5	2
006L/R	Left/Right Foot Pedal 9/16"	2	026	Hexagon Cylinder Cap Bolt M5*10*S4	1
007L/R	Left/Right Crank 9/16"	2	027	Flat Oval Tube Plugs PT70*30*7.5	1
008	Round Knob M16*1.5*27*Φ56	2	028	Hexagon Socket Pan Head Cap Screw M6*12*S5	2
009	Hexagon Socket Pan Head Cap Bolt M8*65*20*S6	4	029	Multi Hex Tool with Phillips Screwdriver S13-14-15	1
010	Flat Washer d8*Ø16*1.5	4	030	Allen Wrench S6	1
011	Square Stabilizer End Cap J100*50*25	4	031	Cross Recessed Countersunk Head Tapping Screws ST4*19*Φ7	2
012	Rear Stabilizer	1	032	Washer d6*Φ12*1	2
013	Bolt t4*49.5*20	4	033	Handshake Tablets	2
014	Bottom Pad Φ65*Φ7.5*12	4	034	Handshake Line Length950 Round Plug	1
015	Front Stabilizer	1	035	Sensor Wire Line Length400 Square Plug	1
016	Hexagon Pan Head Screws Φ7.8*30*M6*15*S5	2	036	Sensor Trunk	1
017	Bearing 608ZZ	4	037	Computer	1
018	Transport Wheel Φ71*Φ19*24	2	038	Pan Head Screw With Cross Recess M5*10	4
019	Pan Head Screw With Cross Recess M5*16*Φ10	2	039	Main Frame	1
020	Flat Washer d5*Φ10*1	2			

**HARDWARE PACKING LIST & TOOLS**

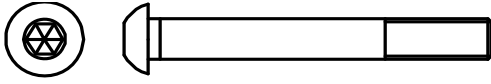

(9) Hexagon Socket Pan Head Cap Bolt  
4PCS



(10) Flat Washer  
4PCS

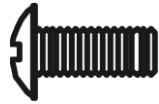

(19) Cross Recessed Pan Head Screw  
2PCS



(20) Flat Washer  
2PCS



(25) Flat Washer  
2PCS

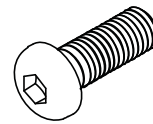

(24) Hexagon Socket Pan Head Cap Screw  
2 PCS



Allen Wrench S6  
1 PC

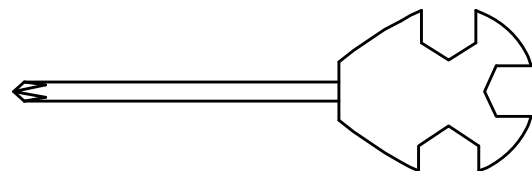

Multi Hex Tool with Phillips  
Screwdriver  
1 PC

## ASSEMBLY

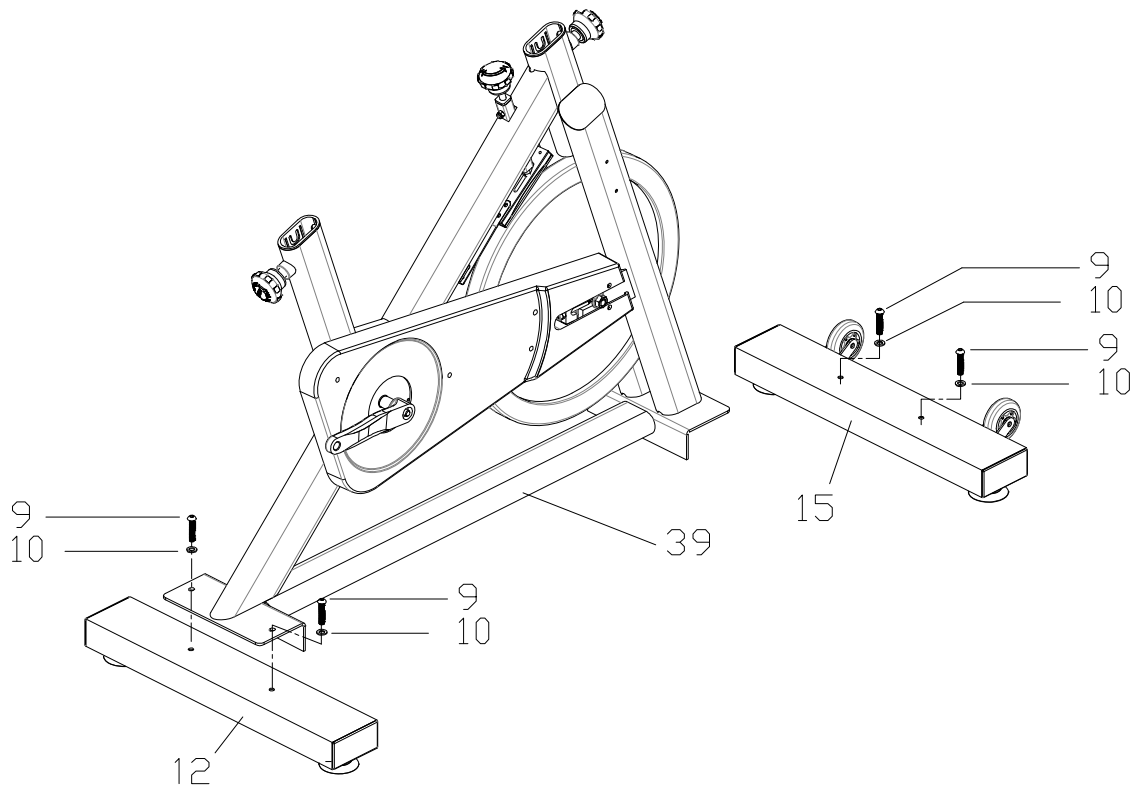

### 1. Front and Rear Stabilizers Installation

Position the Front Stabilizer (15) in front of the Main Frame (39) and align bolt holes. Attach the Front Stabilizer (15) onto the front curve of the Main Frame (39) with two Hexagon Socket Pan Head Cap Bolt (9), two Flat Washer (10). Tighten Hexagon Socket Pan Head Cap Bolt(9)with the Allen Wrench(30) S6 Provided.

Position the Rear Stabilizer (12) behind the Main Frame (39) and align bolt holes. Attach the Rear Stabilizer (12) onto the rear curve of the Main Frame (39) with two Hexagon Socket Pan Head Cap Bolt (9) and two Washers (10). Tighten Hexagon Socket Pan Head Cap Bolt(9)with the Allen Wrench(30) S6 Provided.

### Hardware:



(10) Washer  
4PCS

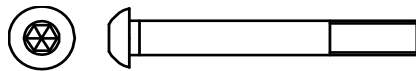

(9)Hexagon Socket Pan Head Cap Bolt  
4PCS



(30) Allen Wrench  
S6

# ASSEMBLY

## Important:

Please make sure the right foot pedal matches up with the right crank and the left foot pedal matches up with the left crank. If reversed the cranks may become damaged or stripped.

## Tool:

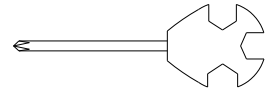

Multi Hex Tool with Phillips Screwdriver

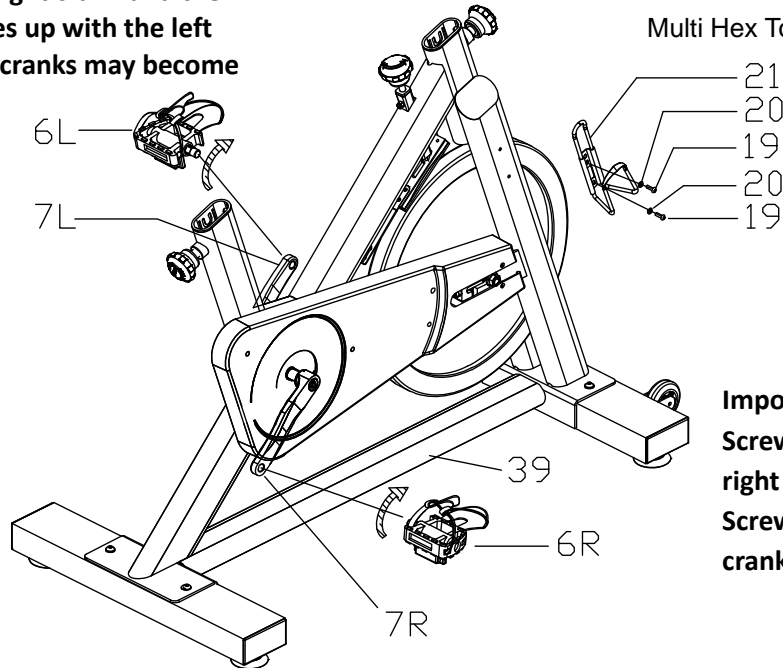

## Important:

Screw Right Foot Pedal (6R) into right crank clockwise!  
Screw Left Foot Pedal (6L) into Left crank counter-clockwise!

## 1. Water Bottle Holder Installation

Attach the Water Bottle Holder(21) onto Main Frame(39) with two Washers(20) and two Cross Recessed Pan Head Screw(19). Tighten bolts with the Multi Hex Tool with Phillips Screwdriver provided.

## 2. Foot Pedals Installation

**The Cranks and Foot Pedals are marked “R” for Right and “L” for Left.**

Insert the pedal shaft of Left Foot Pedal(6L) into threaded hole in the Left Crank (7L). Turn the pedal shaft by hand in the counter-clockwise direction until snug.

**Note: DO NOT turn the pedal shaft in the clockwise direction, doing so will strip the threads.**

Tighten the pedal shaft of Left Foot Pedal (6L) with the Multi Hex Tool with Phillips Screwdriver provided.

Insert pedal shaft of Right Foot Pedal (6R) into threaded hole in Right Crank (7R).

Turn the pedal shaft by hand in the clockwise direction until snug. Tighten pedal shaft of Right Foot Pedal (6R) with the Multi Hex Tool with Phillips Screwdriver provided.

## Hardware:



(20)Washer  
2 PCS



(19)Cross recessed Pan Head Screw  
2 PCS

## ASSEMBLY

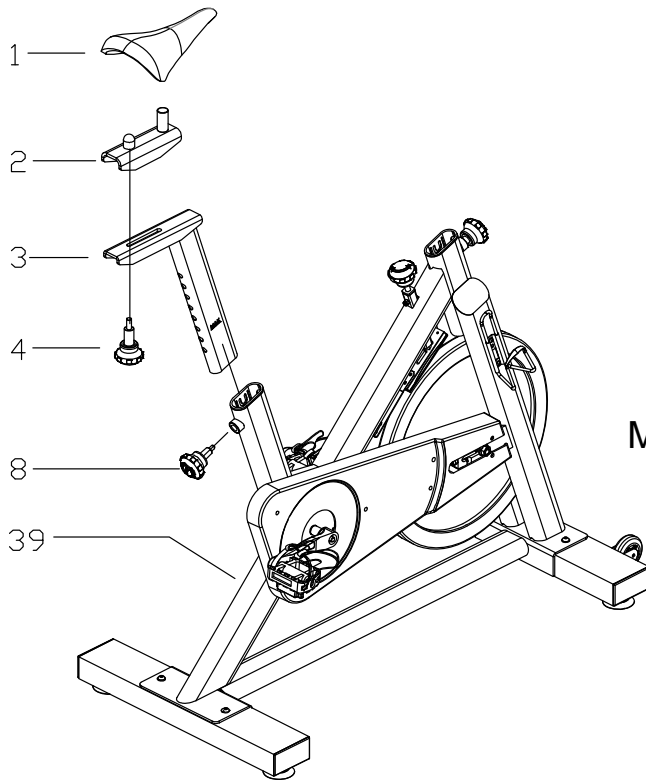

### Tool:

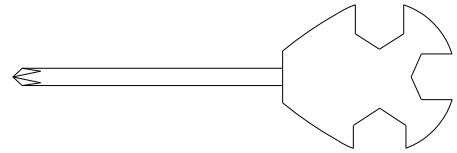

Multi Hex Tool with Phillips Screwdriver

### 1. Seat Post, Seat, Seat Sliding Tube, and Handlebar Post Installation

#### Seat Post Installation

Turn the Round Knob (8) on the Main Frame (39) in a counterclockwise direction until it can be pulled out. Pull out the Round Knob (8) and then insert the Seat Post (3) into the tube of the Main Frame (39). Slide the Seat Post (3) up or down direction to the suitable position. Lock the Seat Post (3) in place by releasing the Round Knob (8) and sliding the Seat Post (3) up or down slightly until the Round Knob (8) "pops" down into the locked position. For added safety, tighten the Round Knob (8) in a clockwise direction.

**NOTE: When adjusting the height of seat post, the MAX line cannot be higher than the edge of plastic bushing.**

#### 2. Seat Installation

Turn the Round Knob (4) on the Seat Post (3) in a counterclockwise direction until it can be pulled out. Pull out the Round Knob (4) and then put the Seat Bracket (2) onto the Seat Post (3). Slide the Seat Bracket (2) in place by releasing the Round Knob (4) and sliding the Seat Bracket (2) back and for the slightly until the Round Knob (4) "pop" down in the locked position. For added safety, tighten the Round Knob (4) in a clockwise direction. Put the Seat (1) onto the Seat Bracket (2). Then tighten the Seat (1) with Multi Hex Tool with Phillips Screwdriver onto the Seat Bracket (2).

## ASSEMBLY

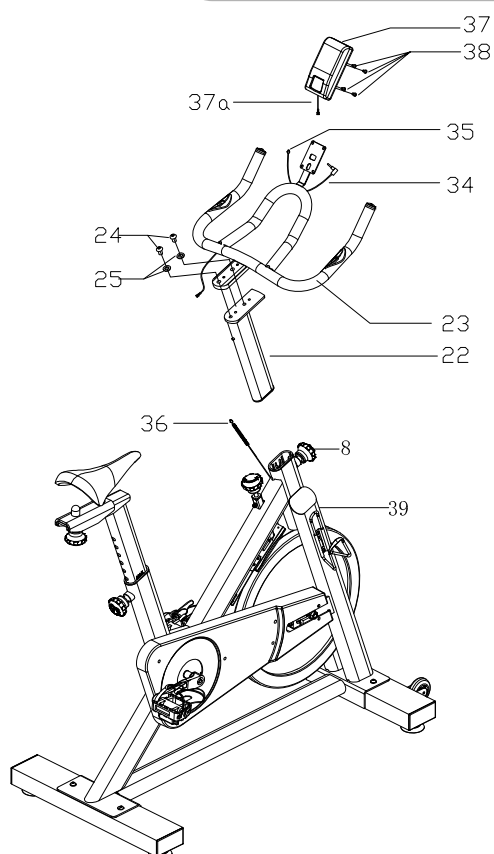

### Tool:

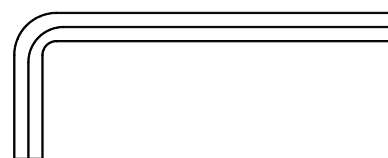

Allen Wrench S6

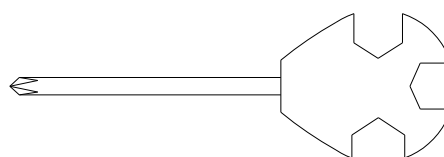

Multi Hex Tool with Phillips Screwdriver  
S13, S14, S15

### 1. Handlebar Post Installation

Turn the Round Knob (8) on the Main Frame (39) in a counterclockwise direction until it can be pulled out. Pull out the Round Knob (8) and then insert the Handlebar Post (22) into the tube of the Main Frame (39). Slide the Handlebar Post (22) up or down direction to the suitable position. Lock the Handlebar Post (22) in place by releasing the Round Knob (29) and sliding the Handlebar Post (22) up or down slightly until the Round Knob (8) "pops" down into the locked position. For added safety, tighten the Round Knob (8) in a clockwise direction.

**NOTE: When adjusting the height of seat post, the MAX line cannot be higher than the edge of plastic bushing.**

### 2. Handlebar Installation

Attach the Handlebar (23) onto the Handlebar Post (22). Through Two Hexagon Socket Pan Head Cap Bolts (24), Two and Washers (25). Tighten bolts (24) with the S6 Allen Wrench and Multi Hex Tool with Phillips Screwdriver.

### 3. Computer Installation.

Use 6mm Allen Wrench to install the Computer (37) into the computer plate on the handle bar and tighten with Phillips pan head cap screw (38).

4. Insert the Sensor Trunk (36) through into the bottom end of Handlebar Post (22) and pull it out from the top end of Handlebar Post (22) connect the Sensor Wire (35). Connect computer wire (37a) with the sensor wire (35) and handlebar wire (34) into the Computer(37)

## ASSEMBLY

### Hardware:

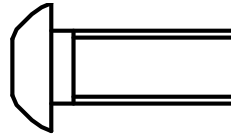
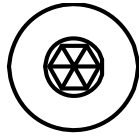

(24) Hexagon Socket Pan Head Cap  
Screw  
2PCS

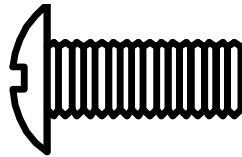

(38) Phillips Pan Head Cap Screw  
4PCS



(25) Washer  
2PCS

## ADJUSTMENTS

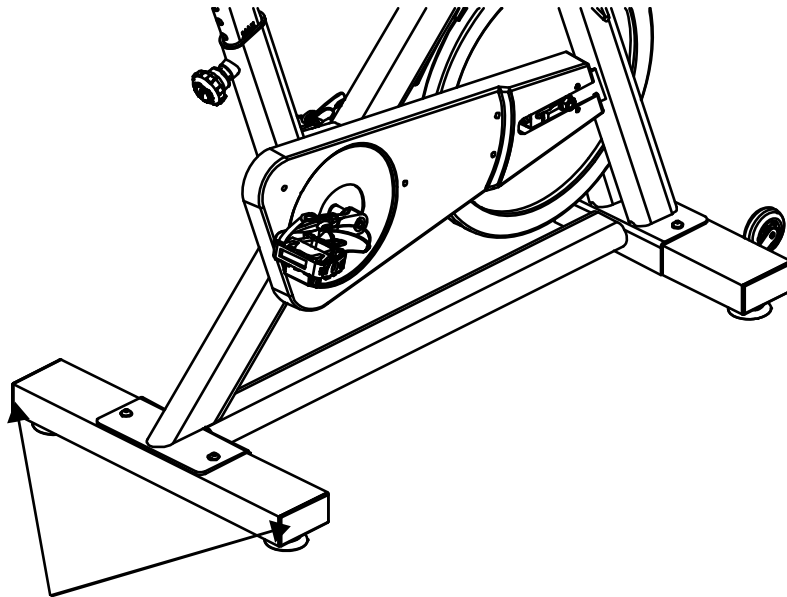

**Rear Stabilizer End Cap**

### **Adjusting the Adjustable Leveler**

Turn the Adjustable Leveler on the front and rear stabilizers as needed to level the bike.

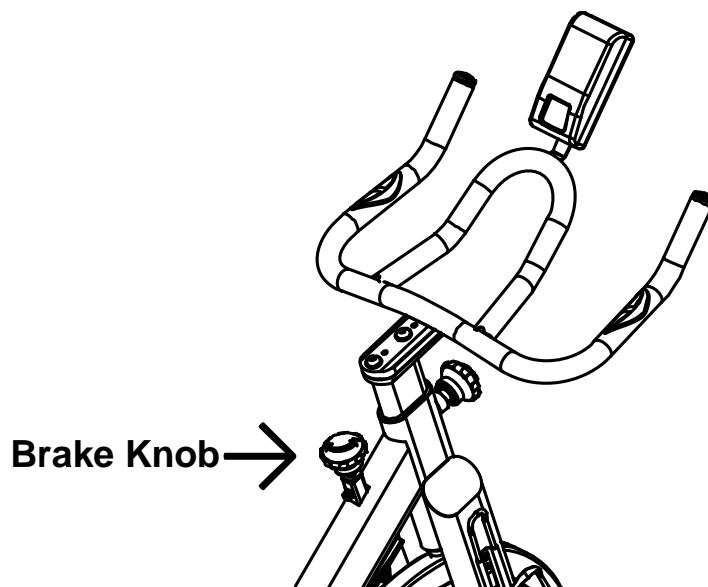

### **Adjusting the Brake Knob**

To increase the tension, turn the Brake Knob in a clockwise direction.

To decrease the tension, turn the Brake Knob in a counterclockwise direction.

## ADJUSTMENTS

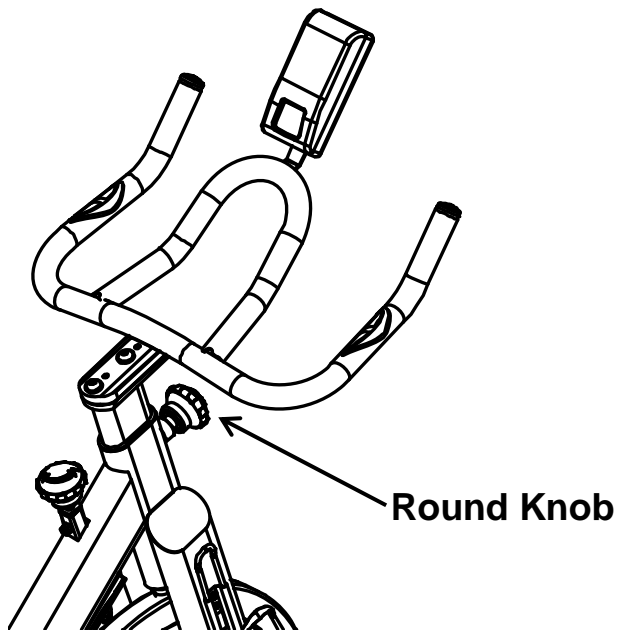

### Adjusting the Handlebar Height

Loosen the Round Knob by turning counterclockwise direction until it can be pulled out. Pull out the Round Knob and then slide the Handlebar Post up or down direction to the suitable position. Lock the Handlebar Post in place by releasing the Round Knob and sliding the Handlebar Post up or down slightly until the Round Knob "pops" down into the locked position. For added safety, tighten the Round Knob in a clockwise direction.

**NOTE: When adjusting the height of handlebar post, the MAX line cannot higher than the edge of plastic bushing.**

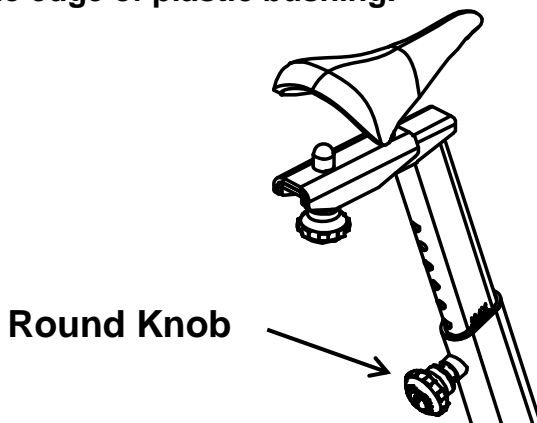

### Adjusting the Seat Height

Loosen the Round Knob by turning counterclockwise direction until it can be pulled out. Pull out the Round Knob and then slide the Seat Post up or down direction to the suitable position. Lock the Seat Post in place by releasing the Round Knob and sliding the Seat Post up or down slightly until the Round Knob "pops" down into the locked position. For added safety, tighten the Round Knob in a clockwise direction.

**NOTE: When adjusting the height of seat post, the MAX line cannot higher than the edge of plastic bushing.**

## ADJUSTMENTS

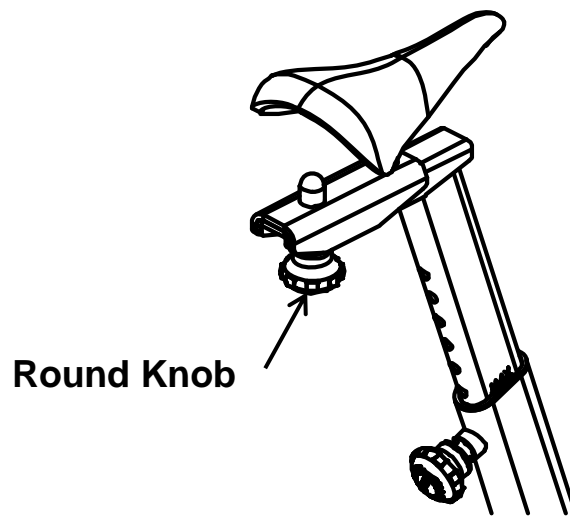

### **Adjusting the Seat Forward or Back**

Loosen the Round Knob by turning it in a counterclockwise direction. Slide the Seat Sliding Tube in a forward direction to the suitable position. Lock the Seat Sliding Tube in place by turning it in a clockwise direction.

## COMPUTER



MODE	To confirm all settings.
SET	To set up the value of TIME, DISTANCE, CALORIES and PULSE. You can hold the button to increase the value fast. (The computer has to be in stop condition.)
RESET	To clear the set-up value. Press RESET key and hold for 2 seconds to reset all function figures.
RECOVERY	To test heart rate recovery status

### FUNCTIONS :

- SCAN:** Displays all function TIME→DISTANCE→CALORIES→PULSE→RPM/SPEED in sequence.
- RPM:** Displays the pedaling Rotation Per Minute. The RPM and SPEED will switch to another display in every 6 seconds after exercise starts.
- SPEED:** Displays the user's exercise speed.
- TIME:**
1. You can press "SET" button to set target time between 0:00 to 99:00 for count down function.
  2. It can be set up by the user or accumulated automatically for count up function.
- DISTANCE:**
1. You can press "SET" button to set target distance between 0:00 to 99:50 for count down function.
  2. It can be set up by the user or accumulated automatically for count up function.
- CALORIES:**
1. You can press "SET" button to set target calories between 0 to 9990 for count down function.
  2. It can be set up by the user or accumulated automatically for count up function
- PULSE:** Displays the user's pulse. User may set the target pulse. When pulse value reaches to the target, the computer will alarm with "Beep" sound.

## COMPUTER

### OPERATION PROCEDURE:

1. Installs 2 pcs of 1.5V “AAA” batteries, then the screen will display as following “Drawing A” and have “Beep” sound at the same time. After that, it goes to the next step to the main menu as “Drawing B”.

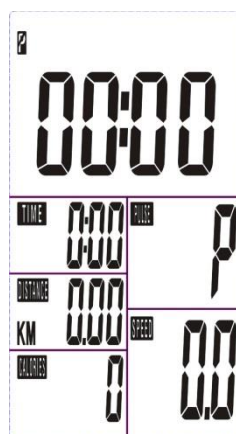
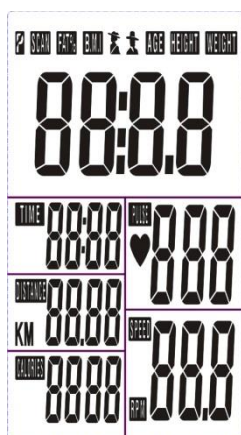

2. Get access to the set-up mode of TIME/DISTANCE/CALORIES/PULSE. When you are in each set-up mode, for example in the time set-up mode, time value is blinking, you can press “SET” button to adjust the value and press “MODE” for confirmation. The set-up of DISTANCE, CALORIES & PULSE is the same as TIME.
3. With any signal been transmitted into the monitor, the value of TIME, DISTANCE, CALORIES start to count up as Drawing C. When there is any function has been preset the target (TIME or DISTANCE or CALORIES), the function will be counting down from the preset to zero while the training starts. Once the target is achieved to zero, the monitor start to beep for 8 seconds, and the function will be counting up from zero directly if the training is going. Press “MODE” button for confirmation and skip to next set-up.
4. In SCAN mode shown as “Drawing C”. RPM/SPEED/TM/DIST/CAL/PULSE will skip to display in every 6 seconds. The order is as follows.

## COMPUTER

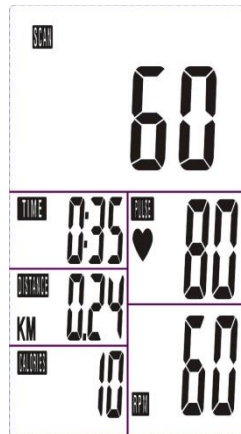

5. You can also press “MODE” button to select single function display except RPM & SPEED function. The RPM & SPEED function will switch display.
6. RECOVERY :
  - (1)When the user presses “RECOVERY” button, the RECOVERY function is active. At this time only PULSE and TIME is working, other functions will not be displayed, and the Sensor Input is not available. TIME starts to count down from ”0 : 60”, Pulse signal will be blinking according user’s heart rate BPM. When Time counts down to “0”, it will show F1~F6.  
(F1 is the best, F6 is the worst)

<b>F1</b>	<b>OUTSTANDING</b>
<b>F2</b>	<b>EXCELLENT</b>
<b>F3</b>	<b>GOOD</b>
<b>F4</b>	<b>FAIR</b>
<b>F5</b>	<b>BELOW AVERAGE</b>
<b>F6</b>	<b>POOR</b>

(2)LCD display as follows: (RECOVERY start condition & end condition) ◦

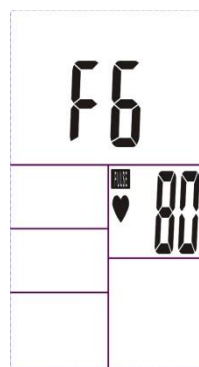
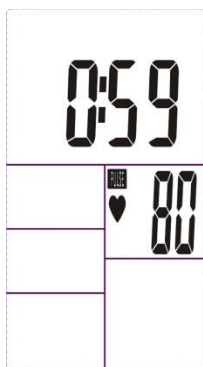

## COMPUTER

- (3) If the count down action to **0:00** is not completed and there is no pulse signal, the count down action has to be done and shown F6.
- (4) If you press the RECOVERY button prior to count down to **0:00**, it will be end and return to the main menu.

Note:

1. Stop training for 4 minutes, the computer will enter to Sleep mode. You may press any button to have the computer restart working, the original value will retain.  
(If re-install batteries, the original value will remove.)
2. If the computer displays abnormally, please re-install batteries and try again.
3. Battery Spec: 1.5V "AAA" (2PCS).

### TROUBLE SHOOTING

**PROBLEM:** The training bike wobbles when in use.

**SOLUTION:** Turn the rear stabilizer end cap on the rear stabilizer as needed to level the bike.

**PROBLEM:** The training bike makes a squeaking noise when in use.

**SOLUTION:** The bolts may be loose on the training bike. Please inspect all of the bolts and tighten any loose bolts.

### MAINTENANCE

#### Cleaning

The training bike can be cleaned with a soft clean damp cloth. Do not use abrasives or solvents on plastic parts. Please wipe your perspiration off the training bike after each use.

Please inspect all assembly bolts, nuts, screws, and pedals on the machine for proper tightness every week.

#### Storage

Store the bike in a clean and dry environment away from children.

## WARM UP

### Quadriceps Stretch

With one hand against a wall for balance, reach behind you and pull your right foot up. Bring your heel as close to your buttocks as possible. Hold for 15 counts and repeat with left foot up.

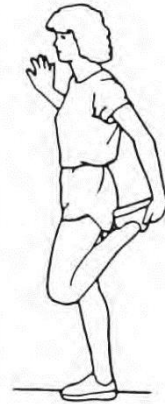

### Inner Thigh Stretch

Sit with the soles of your feet together with your knees pointing outward. Pull your feet as close into your groin as possible.

Gently push your knees towards the floor. Hold for 10 counts.

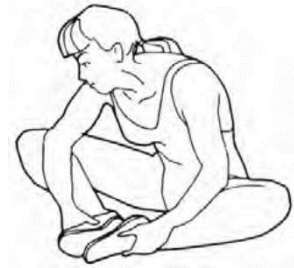

### Toe Touches

Slowly bend forward from your waist, letting your back and shoulders relax as you stretch toward your toes. Reach down as far as you can and hold for 15 counts.

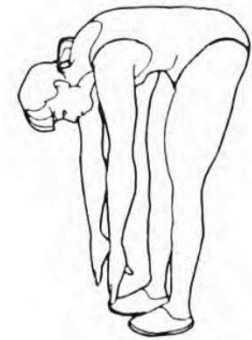

### Hamstring Stretches

Sit with your right leg extended. Rest the sole of your left foot against your right inner thigh. Stretch toward your toe as far as possible. Hold for 15 counts. Relax and then repeat with left leg extended.

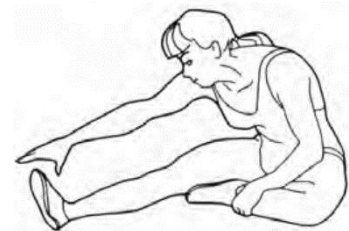

# WARRANTY

## MANUFACTURER'S LIMITED WARRANTY

Paradigm Health & Wellness warrants to the original purchaser that this product is free from defects in material and workmanship when used for the purpose intended, under the conditions that it has be installed and operated in accordance with Paradigm's Owner's Manual. Paradigm's obligation under this warranty applies to the following:

<u>COMPONENT</u>	<u>LENGTH OF WARRANTY</u>
Structural Frame	2 Years
All Other Components (computer display, electronics, upholstery, foam, ball bearings, pulleys, belts, cables, wires, shocks, covers, tension, internal mechanism, wheels, pedals, knobs, accessories and hardware)	90 days

### **Exclusions from Warranty Coverage:**

Paradigm does not warrant against and is not responsible for, and no implied warranty shall be deemed to cover, any product failure, product malfunction, or damages attributable to:

1. improper installation and/or failure to abide by Paradigm's installation guidelines;
2. use of this product beyond normal home use, or in an application for which it was not designed;
3. cosmetic items such as scratches, dents or discolorations;
4. damage caused by normal wear and tear, vandalism, accidental or by animals;
5. any act of Nature (such as fire, flooding, snow, ice, hurricane, earthquake, lightning or other natural diasters), environmental condition (such as air pollution, mold, mildew, etc.), or staining from foreign substances (such as dirt, grease, oil, etc.);
6. normal weathering due to exposure to sunlight, weather and atmosphere which can cause colored surfaces to, among other things, flake, chalk, or accumulate dirt or stains; or
7. improper operation, alteration, handling, storage, abuse or neglect of the products.

**Paradigm, using its sole discretion, will either repair or replace free of charge any part(s) proven to be defective under normal home use. Any repair or replacement shall provide no new warranty coverage, but shall retain only the remaining portion of the original product's warranty. This warranty is offered only to the original purchaser and is not transferable. Proof of original purchase is required.**

### **Ordering Replacement Parts**

Replacement parts can be ordered by calling or emailing our customer service dept:

**1-844-641-7921**

Monday through Friday 8:00 AM - 5:00 PM (PST).

[service@paradigmhw.com](mailto:service@paradigmhw.com)

When ordering replacement parts please have the following information ready:

1. Owner's Manual
2. Model Number
3. Description of Parts
4. Part Number
5. Date of Purchase

**FAX FORM**

**Paradigm Health & Wellness, Inc.**

**PARTS REQUEST FAX FORM**

Please fax this form to (1-626-810-2166)

**OR YOU CAN EMAIL CUSTOMER SERVICE REQUESTS TO  
service@paradigmhw.com**

NAME: \_\_\_\_\_

ADDRESS: \_\_\_\_\_

CITY \_\_\_\_\_ STATE \_\_\_\_\_ ZIP \_\_\_\_\_

TELEPHONE: (Day) \_\_\_\_\_

(Night) \_\_\_\_\_

(Email Address) \_\_\_\_\_

SERIAL#: \_\_\_\_\_

MODEL#: \_\_\_\_\_

PURCHASE DATE: \_\_\_\_\_

PURCHASE FROM: \_\_\_\_\_

PART #	DESCRIPTION	QTY

***“YOUR ORDER WILL BE PROCESSED WITHIN 3 BUSINESS DAYS”***

<b>OFFICIAL USE ONLY</b>
SHIP DATE: _____
TRK #: _____
BACK ORDER: _____