

EVERLAST

POWERPLASMA S SERIES

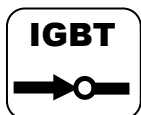

Operator's Manual for the PowerPlasma 60S, 70S, and 80S Safety, Setup and General Use Guide

Rev. 3 0 00215-13

everlastwelders.com

EVERLAST

1-877-755-9353
329 Littlefield Ave. South San Francisco, CA 94080 USA

Specifications and Accessories subject to change without notice.

TABLE OF CONTENTS

Section.....	Page
Letter to the Customer	3
Everlast Contact Information.....	4
Safety Precautions.....	5
Introduction and Specifications.....	9
Unit Specifications.....	10
General Overview.....	11
General Use and Care.....	11
Quick Setup Guide, Torch Connection.....	12
Rear Panel Gas Connection and Wiring.....	13
Compressor and Air Dryer Diagram.....	14
Front Panel Features and Controls.....	15
Rear Panel Features and Controls.....	18
Basic Theory and Function.....	19
Torch.....	23
CNC Connector Pin-Out.....	24
Troubleshooting.....	25

NOTE: Product Specifications and features are subject to change without notice. While every attempt has been made to provide the most accurate and current information possible at the time of publication, this manual is intended to be a general guide and not intended to be exhaustive in its content regarding safety, welding, or the operation/maintenance of this unit. Everlast Power Equipment INC. does not guarantee the accuracy, completeness, authority or authenticity of the information contained within this manual. The owner of this product assumes all liability for its use and maintenance. Everlast Power Equipment INC. does not warrant this product or this document for fitness for any particular purpose, for performance/accuracy or for suitability of application. Furthermore, Everlast Power Equipment INC. does not accept liability for injury or damages, consequential or incidental, resulting from the use of this product or resulting from the content found in this document or accept claims by a third party of such liability.

Dear Customer,

THANKS! You had a choice, and you bought an Everlast. We appreciate you as a customer and hope that you will enjoy years of use from your welder.

Please go directly to the Everlast website to register your unit and receive your warranty information. Your unit registration is important should any information such as product updates or recalls be issued. It is also important so that we may track your satisfaction with Everlast products and services. If you are unable to register by website, contact Everlast directly through the sales department through the main customer service number in your country. Your unit will be registered and warranty will be issued and in full effect. Keep all information regarding your purchase. **In the event of a problem you must contact technical support before your welder can be a candidate for warranty service and returned.**

Please review the current online warranty statement and information found on the website of the Everlast division located in or nearest to your country. Print it for your records and become familiar of its terms and conditions.

Everlast offers full technical support, in several different forms. We have online support available through email, and a welding support forum designed for customers and noncustomer interaction. Technical advisors are active on the forum daily. We also divide our support into two divisions: technical and welding performance. Should you have an issue or question concerning your unit, please contact performance/technical support available through the main company headquarters available in your country. For best service call the appropriate support line and follow up with an email, particularly during off hours, or in the event you cannot reach a live person. In the event you do not reach a live person, particularly during heavy call volume times, holidays, and off hours, leave a message and your call will normally be returned within 24 hours. Also, for quick answers to your basic questions, join the company owned forum available through the website. You'll find knowledgeable, helpful people and staff available to answer your questions, and perhaps find a topic that already addresses your question at <http://www.everlastgenerators.com/forums/>.

Should you need to call or write, always know your model name, purchase date and welder manufacturing inspection date. This will assure the quick and accurate customer service. **REMEMBER: Be as specific and informed as possible. Technical and performance advisors rely upon you to carefully describe the conditions and circumstances of your problem or question. Take notes of any issues as best you can. You may be asked many questions by the advisors to clarify problems or issues that may seem very basic. However, diagnosis procedures MUST be followed to begin the warranty process. Advisors can't assume anything, even with experienced users, and must cover all aspects to properly diagnose the problem. Depending upon your issue, it is advisable to have basic tools handy such as screwdrivers, wrenches, pliers, and even an inexpensive test meter with volt/ohm functions before you call.**

Let us know how we may be of service to you should you have any questions.

Sincerely,

Everlast Customer Service

Serial number: _____

Model number: _____

Date of Purchase _____

EVERLAST

Contact Information

Everlast US:

Everlast consumer satisfaction email: sales@everlastwelders.com

Everlast Website: everlastwelders.com

Everlast Technical Support: support@everlastwelders.com

Everlast Support Forum: <http://www.everlastgenerators.com/forums/index.php>

Main toll free number: 1-877-755 WELD (9353) 9am—5pm PST M-F

11am-4pm PST Sat.

FAX: 1-650-588-8817

Everlast Canada:

Everlast consumer satisfaction email: sales@everlastwelders.ca

Everlast Website: everlastwelders.ca

Everlast Technical Support: sales@everlastwelders.ca

Telephone: 905-637-1637 9am-4:30pm EST M-F

10am-1pm EST Sat.

FAX: 1-905-639-2817

Everlast Australia:

Sydney: 5A Karloo Parade Newport NSW 2106

(02) 9999 2949

Port Macquarie: 2B Pandorea Place Port Macquarie

(02) 8209 3389

After hours support: 0413 447 492

Everlast Technical Support: support@pickproducts.com

SAFETY PRECAUTIONS

Everlast is dedicated to providing you with the best possible equipment and service to meet the demanding jobs that you have. We want to go beyond delivering a satisfactory product to you. That is the reason we offer technical support to assist you with your needs should an occasion occur. With proper use and care your product should deliver years of trouble free service.



Safe operation and proper maintenance is your responsibility.

We have compiled this operator's manual, to instruct you in basic safety, operation and maintenance of your Everlast product to give you the best possible experience. Much of welding and cutting is based upon experience and common sense. As thorough as this welding manual may be, it is no substitute for either. Exercise extreme caution and care in all activities related to welding or cutting. Your safety, health and even life depends upon it. While accidents are never planned, preventing an accident requires careful planning.

Please carefully read this manual before you operate your Everlast unit. This manual is not only for the use of the machine, but to assist in obtaining the best performance out of your unit. Do not operate the unit until you have read this manual and you are thoroughly familiar with the safe operation of the unit. If you feel you need more information please contact Everlast Support.

The warranty does not cover improper use, maintenance or consumables. **Do not attempt to alter or defeat any piece or part of your unit, particularly any safety device.** Keep all shields and covers in place during unit operation should an unlikely failure of internal components result in the possible presence of sparks and explosions. If a failure occurs, discontinue further use until malfunctioning parts or accessories have been repaired or replaced by qualified personnel.



Note on High Frequency electromagnetic disturbances:

Certain welding and cutting processes generate High Frequency (HF) waves. These waves may disturb sensitive electronic equipment such as televisions, radios, computers, cell phones, and related equipment. High Frequency may also interfere with fluorescent lights. Consult with a *licensed* electrician if disturbance is noted. Sometimes, improper wire routing or poor shielding may be the cause.



HF can interfere with pacemakers. See EMF warnings in following safety section for further information. Always consult your physician before entering an area known to have welding or cutting equipment if you have a pacemaker.

SAFETY PRECAUTIONS



These safety precautions are for protection of safety and health. Failure to follow these guidelines may result in serious injury or death. Be careful to read and follow all cautions and warnings. Protect yourself and others.



Welding and cutting processes produce high levels of ultraviolet (UV) radiation that can cause severe skin burn and damage. There are other potential hazards involved with welding such as severe burns and respiratory related illnesses. Therefore observe the following to minimize potential accidents and injury:



Use appropriate safety glasses with wrap around shields while in the work area, even under welding helmets to protect your eyes from flying sparks and debris. When chipping slag or grinding, goggles and face shields may be required.



When welding or cutting, always use an approved shielding device, with the correct shade of filter installed. Always use a welding helmet in good condition. Discard any broken or cracked filters or helmets. Using broken or cracked filters or helmets can cause severe eye injury and burn. Filter shades of no less than shade 5 for cutting and no less than shade 9 for welding are highly recommended. Shades greater than 9 may be required for high amperage welds. Keep filter lenses clean and clear for maximum visibility. It is also advisable to consult with your eye doctor should you wear contacts for corrective vision before you wear them while welding.



Do not allow personnel to watch or observe the welding or cutting operation unless fully protected by a filter screen, protective curtains or equivalent protective equipment. If no protection is available, exclude them from the work area. Even brief exposure to the rays from the welding arc can damage unprotected eyes.



Always wear hearing protection because welding and cutting can be extremely noisy. Ear protection is necessary to prevent hearing loss. Even prolonged low levels of noise has been known to create long term hearing damage. Hearing protection also further protects against hot sparks and debris from entering the ear canal and doing harm.



Always wear personal protective clothing. Flame proof clothing is required at all times. Sparks and hot metal can lodge in pockets, hems and cuffs. Make sure loose clothing is tucked in neatly. Leather aprons and jackets are recommended. Suitable welding jackets and coats may be purchased made from fire proof material from welding supply stores. Discard any burned or frayed clothing. Keep clothing away from oil, grease and flammable liquids.



Leather boots or steel toed leather boots with rubber bottoms are required for adequate foot protection. Canvas, polyester and other man made materials often found in shoes will either burn or melt. Rubber or other non conductive soles are necessary to help protect from electrical shock.



Flame proof and insulated gauntlet gloves are required whether welding or cutting or handling metal. Simple work gloves for the garden or chore work are not sufficient. Gauntlet type welding gloves are available from your local welding supply companies. Never attempt to weld with out gloves. Welding with out gloves can result in serious burns and electrical shock. If your hand or body parts comes into contact with the arc of a plasma cutter or welder, instant and serious burns will occur. **Proper hand protection is required at all times when working with welding or cutting machines!**

SAFETY PRECAUTIONS



WARNING! Persons with pacemakers should not weld, cut or be in the welding area until they consult with their physician. Some pacemakers are sensitive to EMF radiation and could severely malfunction while welding or while being in the vicinity of someone welding. *Serious injury or death may occur!*



Welding and plasma cutting processes generate electro-magnetic fields and radiation. While the effects of EMF radiation are not known, it is suspected that there may be some harm from long term exposure to electromagnetic fields. Therefore, certain precautions should be taken to minimize exposure:

- Lay welding leads and lines neatly away from the body.
- Never coil cables around the body.
- Secure cables with tape if necessary to keep from the body.
- Keep all cables and leads on the same side the body.
- Never stand between cables or leads.
- Keep as far away from the power source (welder) as possible while welding.
- Never stand between the ground clamp and the torch.
- Keep the ground clamp grounded as close to the weld or cut as possible.



Welding and cutting processes pose certain inhalation risks. Be sure to follow any guidelines from your chosen consumable and electrode suppliers regarding possible need for respiratory equipment while welding or cutting. Always weld with adequate ventilation. Never weld in closed rooms or confined spaces. Fumes and gases released while welding or cutting may be poisonous. Take precautions at all times. Any burning of the eyes, nose or throat are signs that you need to increase ventilation.

- Stop immediately and relocate work if necessary until adequate ventilation is obtained.
- Stop work completely and seek medical help if irritation and discomfort persists.



WARNING! Do not weld on galvanized steel, stainless steel, beryllium, titanium, copper, cadmium, lead or zinc without proper respiratory equipment and or ventilation.



WARNING! This product when used for welding or cutting produces fumes and gases which contains chemicals known to the State of California to cause birth defects and in some cases cancer. (California Safety and Health Code §25249.5 *et seq.*)



WARNING! Do not weld or cut around Chlorinated solvents or degreasing areas. Release of Phosgene gas can be deadly. Consider all chemicals to have potential deadly results if welded on or near metal containing residual amounts of chemicals.



Keep all cylinders upright and chained to a wall or appropriate holding pen. Certain regulations regarding high pressure cylinders can be obtained from OSHA or local regulatory agency. Consult also with your welding supply company in your area for further recommendations. The regulatory changes are frequent so keep informed.



All cylinders have a potential explosion hazard. When not in use, keep capped and closed. Store chained so that overturn is not likely. Transporting cylinders incorrectly can lead to an explosion. Do not attempt to adapt regulators to fit cylinders. Do not use faulty regulators. Do not allow cylinders to come into contact with work piece or work. Do not weld or strike arcs on cylinders. Keep cylinders away from direct heat, flame and sparks.

SAFETY PRECAUTIONS

continued



WARNING! Electrical shock can kill. Make sure all electrical equipment is properly grounded. Do not use frayed, cut or otherwise damaged cables and leads. Do not stand, lean or rest on ground clamp. Do not stand in water or damp areas while welding or cutting. Keep work surface dry. Do not use welder or plasma cutter in the rain or in extremely humid conditions. Use dry rubber soled shoes and dry gloves when welding or cutting to insulate against electrical shock. Turn machine on or off only with gloved hand. Keep all parts of the body insulated from work, and work tables. Keep away from direct contact with skin against work. If tight or close quarters necessitates standing or resting on work piece, insulate with dry boards and rubber mats designed to insulate the body from direct contact.



All work cables, leads, and hoses pose trip hazards. Be aware of their location and make sure all personnel in area are advised of their location. Taping or securing cables with appropriate restraints can help reduce trips and falls.



WARNING! Fire and explosions are real risks while welding or cutting. Always keep fire extinguishers close by and additionally a water hose or bucket of sand. Periodically check work area for smoldering embers or smoke. It is a good idea to have someone help watch for possible fires while you are welding. Sparks and hot metal may travel a long distance. They may go into cracks in walls and floors and start a fire that would not be immediately visible. Here are some things you can do to reduce the possibility of fire or explosion:

- Keep all combustible materials including rags and spare clothing away from area.
- Keep all flammable fuels and liquids stored separately from work area.
- Visually inspect work area when job is completed for the slightest traces of smoke or embers.
- If welding or cutting outside, make sure you are in a cleared off area, free from dry tender and debris that might start a forest or grass fire.
- Do not weld on tanks, drums or barrels that are closed, pressurized or anything that held flammable liquid or material.



Metal is hot after welding or cutting! Always use gloves and or tongs when handling hot pieces of metal. Remember to place hot metal on fire-proof surfaces after handling. Serious burns and injury can result if material is improperly handled.



WARNING! Faulty or poorly maintained equipment can cause injury or death. Proper maintenance is your responsibility. Make sure all equipment is properly maintained and serviced by qualified personnel. Do not abuse or misuse equipment. Keep all covers in place. A faulty machine may shoot sparks or may have exploding parts. Touching uncovered parts inside machine can cause discharge of high amounts of electricity. **Do not allow employees to operate poorly serviced equipment.** Always check condition of equipment thoroughly before start up. Disconnect unit from power source before any service attempt is made and for long term storage or electrical storms.



Further information can be obtained from The American Welding Society (AWS) that relates directly to safe welding and plasma cutting. Additionally, your local welding supply company may have additional pamphlets available concerning their products. Do not operate machinery until your are comfortable with proper operation and are able to assume inherent risks of cutting or welding.

PowerPlasma 60S, 70S, and 80S



12 ft. S-75 Trafimet Torch



Work Clamp



Consumable Starter Kit
(Qty. and items may vary)



Regulator Assembly with Bracket

NOTE: Accessory and consumable style and quantities are subject to change without notice.

SECTION 1**INTRODUCTION AND SPECIFICATIONS**

Specification	PowerPlasma 60S	PowerPlasma 70S	PowerPlasma 80S
Inverter Type	Analog, Siemens IGBT Module Construction	Analog, Siemens IGBT Module Construction	Analog, Siemens IGBT Module Construction
Minimum/Maximum Rated Output	20 A/88 V - 60 A/108 V	20 A/88 V-70 A/110V	20 A/88 V-80 A/112 V
Start Type	Blow-Back Type	Blow-Back Type	Blow-Back Type
Torch Type	Trafimet S-75 12 ft.	Trafimet S-75 12 ft.	Trafimet S-75 12 ft.
Duty Cycle @ Rated Amps/Volts (40° C) (Output V/A)	60% @ 60 A/ 108 V 100% @ 46.5 A/ 98.6 V	60% @ 70 A/ 110 V 100% @ 55 A/102 V	60% @ 80 A/112 V 100% @ 63 A/105 V
OCV (U0)	200 V	200 V	200 V
Voltage Input (U1)	Standard 220/ 240 V; 50/60Hz 1 Phase	Standard 220/ 240 V; 50/60Hz 1 Phase	Standard 220/ 240 V; 50/60Hz 1 Phase (3 phase Optional)
Maximum Inrush Amps (I1MAX)	50 A @ 220 V; 46 A @ 240 V	60 @ 220 V; 55 A@ 240 V	70 @220 V; 64 @ 240 V
Maximum Rated Effective Amps (I1EFF)	40 A @ 220 V; 36 A @ 240 V	47 A @ 220 V; 44 @ 240 V	55 A @ 220 V; 51 A @ 240 V
CNC Port	Yes	Yes	Yes
Air Post Flow Timer	Adjustable	Adjustable	Adjustable
Minimum Air Compressor Requirement	5 CFM @ 90 psi/ 30-60 gallon reserve	6 CFM @ 90 psi/ 30-60 gallon reserve	7 CFM @ 90 psi/ 30-60 gallon reserve
Duty Cycle/ Over Current Protection	Yes	Yes	Yes
Minimum Operating Air Pressure (Safety Cut-Out Threshold)	35 psi	35 psi	35 psi
Recommended Operating Air Pressure (Set with Air Flow set "Test")	70-75 psi	70-75 psi	70-75 psi
Maximum Permissible Static Air Pressure (Without air flowing)	85 psi	85 psi	85 psi
Maximum Supplied Air Pressure (From Compressor/Tank)	90 psi	90 psi	90 psi
Recommended Daily Maximum Average Cut Thickness (Hand Torch)	5/8"	3/4"	1"
Recommended Daily Maximum Average Cut Thickness (CNC)	3/8"	1/2"	5/8"
Rated Maximum Quality Cut @ 10-12 IPM (Steel)	7/8"	1 1/8"	1 1/4"
Max Severance Cut @ 3 IPM (Steel)	1 1/4"	1 3/8"	1 1/2"
Minimum Water Ingress Protection Standard	IP21S	IP21S	IP21S
Efficiency	>85%	>85%	>85%
Cooling Method	Full Time High Velocity Fan with Tunnel design	Full Time High Velocity Fan with Tunnel design	Full Time High Velocity Fan with Tunnel design
Dimensions (approximate)	18" H X 10" W X 25" L	18" H X 10" W X 25" L	18" H X 10" W X 25" L
Weight (Bare Unit)	65 lbs	68 lbs	70 lbs

Decrease maximum cut thickness values for aluminum and stainless by approximately 35%.

SECTION 1

INTRODUCTION AND SPECIFICATIONS

General overview: The new, redesigned PowerPlasma S-series are non high frequency machines. The “blow-back” type start is safe for use in CNC applications and is ideal for general use. The elimination of the HF points within the unit also improves reliability and removes the need for regular HF point gap maintenance. Blow-back type start involves a rear-ward movement of the electrode within the torch head when forced by the air pressure. When air pressure is applied the movement of the electrode off its seated position against the inner surface of the circuit grounded nozzle creates a spark, energizing the plasma stream. This type start means that it has an inherent pilot arc design so that cutting can be done on any surface and is ideal for cutting items like expanded metal or uneven surfaces. There are several other key features on the PowerPlasma S series:

- A. Siemens IGBT modules improve reliability while make servicing a unit quicker, and more cost efficient. Most parts are standard components reducing the cost of long term repair.
- B. Full bridge design features soft switching technology which further extends IGBT component life and extends its capabilities.
- C. Trafimet standard s-75 “blowback” design torches with a Euro-type Central connector makes hook up and maintenance easy.
- D. The new 3 second Tip Saver feature improves consumable life by limiting the pilot arc time to 3 seconds. A normal mode is also available for extended cutting on expanded/perforated metal and irregular surfaces. In the tip saver mode, once the pilot arc has been engaged for 3 seconds the pilot arc will extinguish and the arc can be re-struck.
- E. Post Air flow control is a unique feature with Everlast and provides better post flow control of the air so consumable life is increased and the torch can be cooled for an extended period of time if desired.
- F. OK to Cut light stays lit while the plasma cutter is within the minimum limits needed for the torch to function without burning up. If the light goes out an automatic override kicks in and shuts down the unit until the air pressure is back to a sustainable level. Minimum air pressure is set at about 35 psi, which is not ideal, but will prevent premature torch failure.

General Use and Care: The Plasma cutter is designed for use in many industrial environments such as ship yards, fabrication shops and pipelines. However, care should be taken to keep the unit out of direct contact with water spray. The unit is rated IP21S, which rates it for light contact with dripping water. It is a good idea to remove the welder from the vicinity of any water or moisture

source to reduce the possibility of electrocution or shock. Never operate in standing water. This unit has a high Open circuit voltage further necessitating safe operating practices. Use in a protected/sheltered area while connected to a CNC water table. The operator should be careful to observe spashing/spraying water in the direction of the plasma cutter. Every 1-2 months, depending upon use, the welder should be unplugged, opened up and carefully cleaned with dry, compressed air. Regular maintenance will extend the life of the unit.

IMPORTANT: Before opening the unit for any reason, make sure the unit has been unplugged for at least 10 minutes to allow time for the capacitors to fully discharge. Severe shock and/or death can occur.

Do not restrict air flow or movement of air around the plasma cutter. Allow a buffer distance of 2 ft. from all sides if possible, with a minimum distance of at least 18” clearance.

Do not direct metallic dust or any dirt intentionally toward the machine, particularly in grinding and cutting operations. Make sure the panel is protected from damage during welding and cutting operations by flipping down the clear protective cover.

Duty Cycle. The duty cycle has been determined for the S series. The duty cycle is rated for 60% at maximum output amps. The duty cycle is based off a 10 minute duty cycle rating at 40° C. This means that the unit is capable of being operated at the stated amps for 6 out of every 10 minutes without a break to cool down the unit. This does NOT mean that the unit can work 60% of any greater length of time. A full 4 minute rest is needed for maximum life. The temperature light will come on and the welder will automatically stop welding when an overheat condition has occurred. If the light is on but the unit does not stop cutting this does not necessarily mean that you have not exceeded duty cycle. Heat will continue to be generated by and transferred to the electronics after cutting has ceased. Operation in humid, or hot conditions can affect duty cycle as well. Do not shut down an overheated cutter until it has safely cooled. Once the overheated condition has cleared, cutting may resume. Do not operate the plasma cutter with the covers removed for safety and overheating concerns.

This manual has been compiled to give an overview of operation and is designed to offer information centered around safe, practical use of the plasma cutter. Do not operate this machine until you have fully read the manual, including the safety section.

QUICK SETUP GUIDE: CONNECTIONS

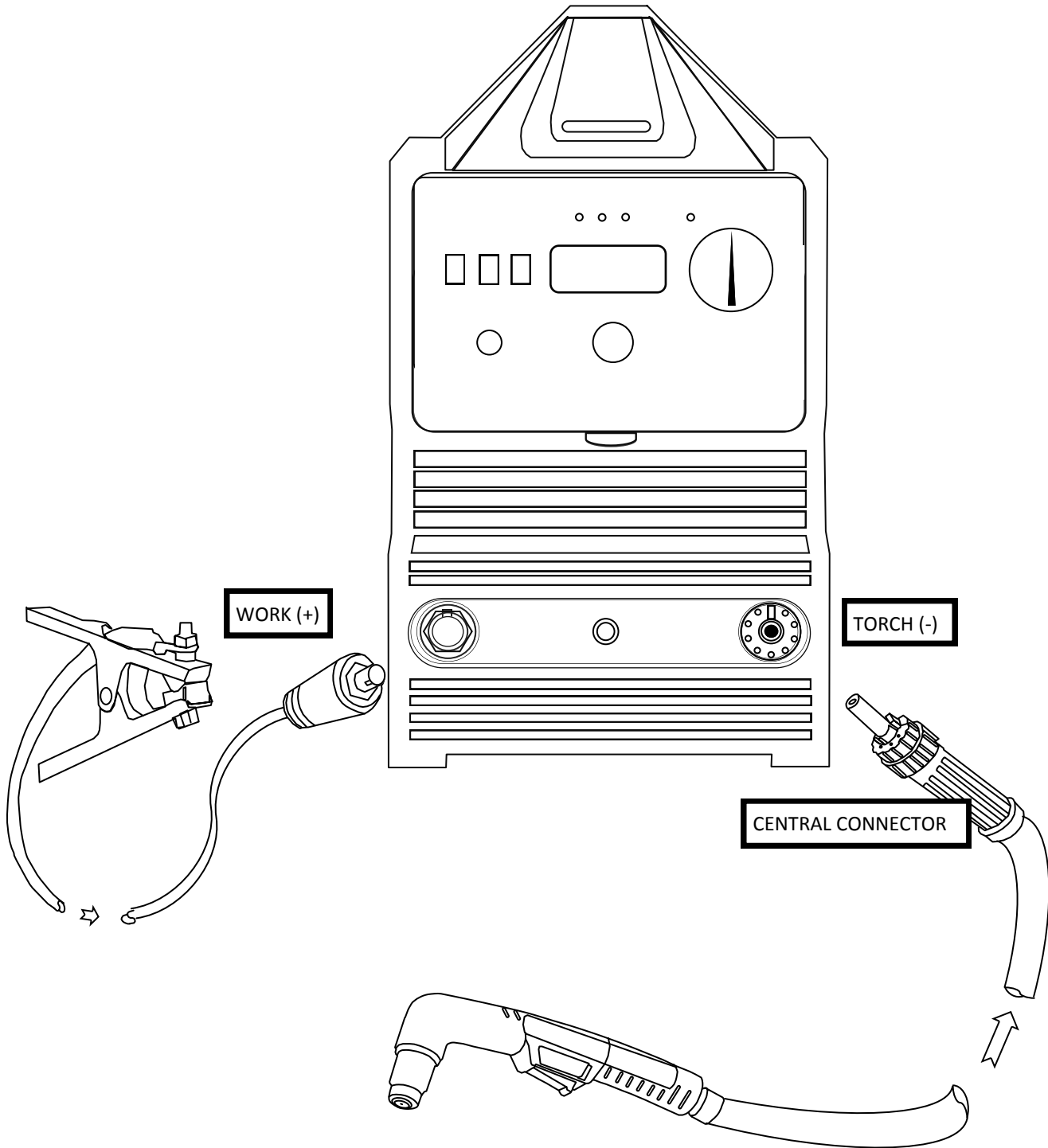

**QUICK SETUP GUIDE: REAR CONNECTIONS AND WIRING
(US/Canada)**

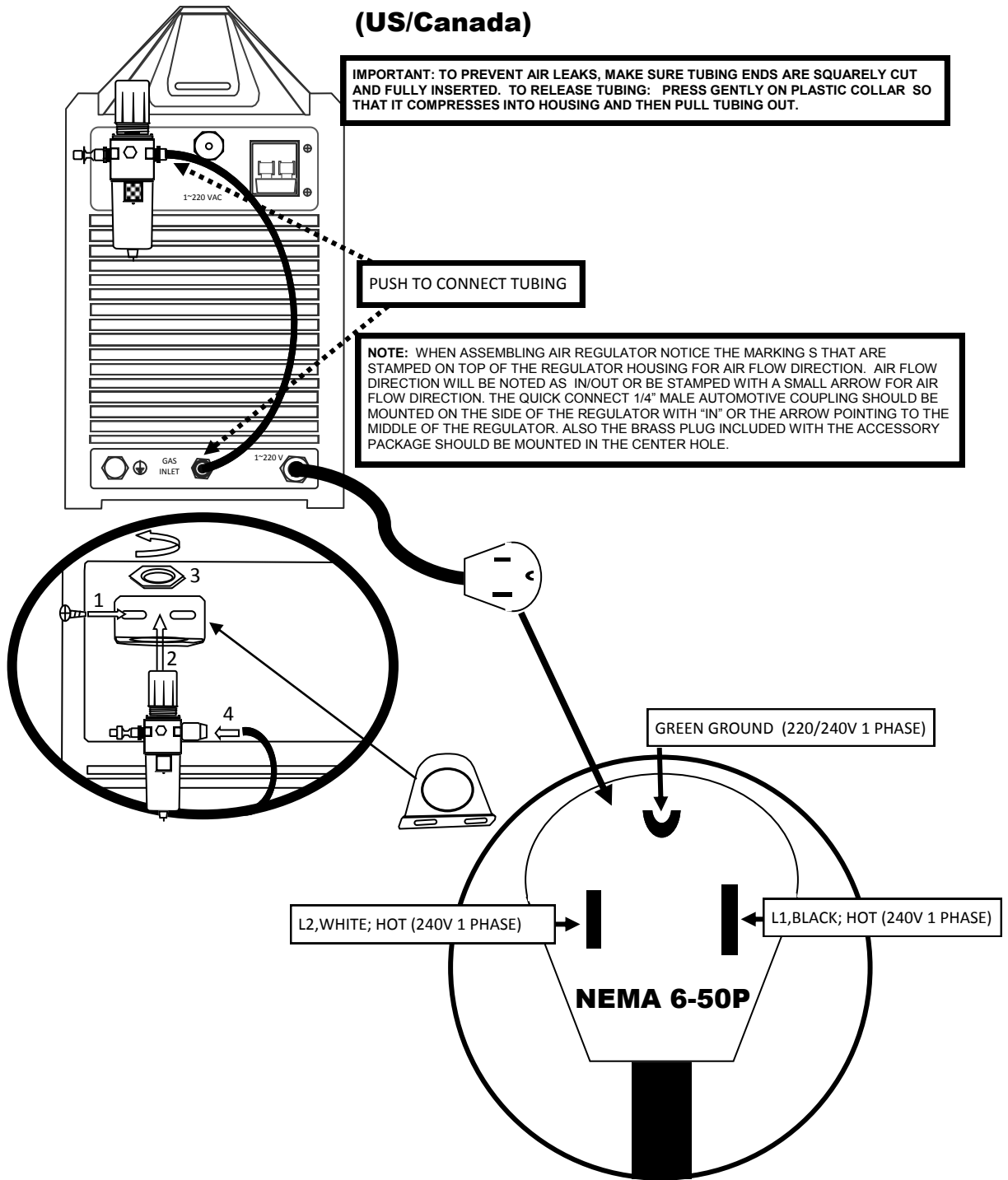

IMPORTANT: ALWAYS CONSULT A LICENSED ELECTRICIAN AND LOCAL CODES BEFORE RE-WIRING YOUR WELDER OR ATTEMPTING TO MAKE ANY ELECTRICAL CONNECTION.

SUPPLIED PLUG IS A NEMA 6-50P, THE STANDARD PLUG FOR MOST 1 PHASE 240 V WELDERS IN THE US AND CANADA.

QUICK SETUP GUIDE: REAR CONNECTIONS AND WIRING

Compressor and Dryer Diagram

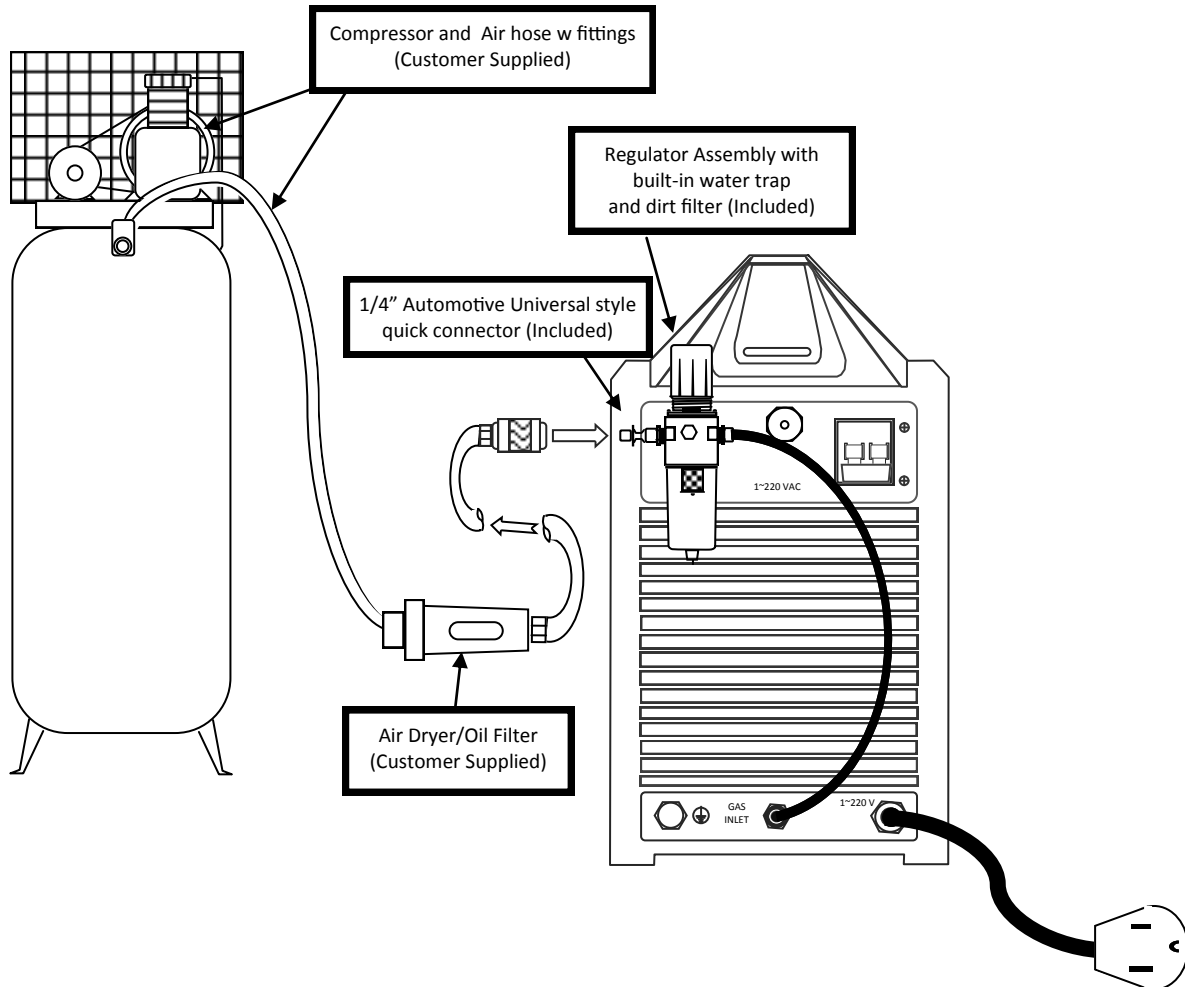

NOTE: A SEPARATE AIR DRYER BETWEEN THE AIR COMPRESSOR AND REGULATOR ASSEMBLY MUST BE INSTALLED. IT SHOULD BE INSTALLED AS CLOSE TO THE PLASMA CUTTER AS PRACTICAL. THIS IS A CUSTOMER SUPPLIED ITEM. THIS WILL REDUCE CUTTING ISSUES SUCH AS SPITTING, POPPING AND RAPID CONSUMABLE WEAR. THE REGULATOR/FILTER THAT IS INCLUDED IS NOT SUFFICIENT TO REMOVE ALL MOISTURE. IT SERVES ONLY AS A WATER TRAP AND FINE SEDIMENT FILTER. ANY AIR COMPRESSOR SYSTEM PRODUCES MOISTURE IN ALMOST ANY ENVIRONMENT REGARDLESS OF HUMIDITY LEVELS. DAILY DRAINING OF THE AIR COMPRESSOR IS RECOMMENDED AS WELL. THE AIR SUPPLIED TO THE PLASMA CUTTER SHOULD BE OF SIMILAR QUALITY USED FOR AUTOMOTIVE PAINTING. DIFFERENT STYLES OF DRYERS ARE AVAILABLE. THE MOST INEXPENSIVE AND COMMONLY AVAILABLE IS THE REPLACEABLE DESSICANT TYPE USED FOR AUTOMOTIVE PAINTING. DAMAGE DONE TO THE TORCH AND THE PLASMA CUTTER (INCLUDING BUT NOT LIMITED TO: SHORTING, CORROSION AND DETERIORATION OF INTERNAL LINES AND COMPONENTS) AS A RESULT OF EXCESS MOISTURE IS NOT COVERED UNDER WARRANTY. ADDITIONALLY, A FILTER SHOULD BE INSTALLED IN-LINE OR AT THE COMPRESSOR THAT WILL FILTER ANY EXCESS OIL OR OIL BLOW-BY FROM THE LINE IF NECESSARY. DO NOT USE WITH OILING SYSTEMS DESIGNED TO AUTOMATICALLY LUBRICATE AIR TOOLS. IT IS ADVISABLE TO USE THE PLASMA CUTTER WITH A NEW AIR HOSE/LINE THAT IS FRESH WITHOUT MOISTURE OR LUBE CONTAMINATION. IF AIR PRESSURE DROPS FROM THE COMPRESSOR TO THE CUTTER MORE THAN 5-10 PSI, OR AIR FLOW IS INSUFFICIENT, INCREASE TO A LARGER SIZE DRYER/FILTER. FAILURE TO USE THE PROPER DRYER/FILTER IS THE NUMBER ONE CAUSE OF CUTTING ISSUES.

FRONT PANEL FEATURES AND CONTROLS

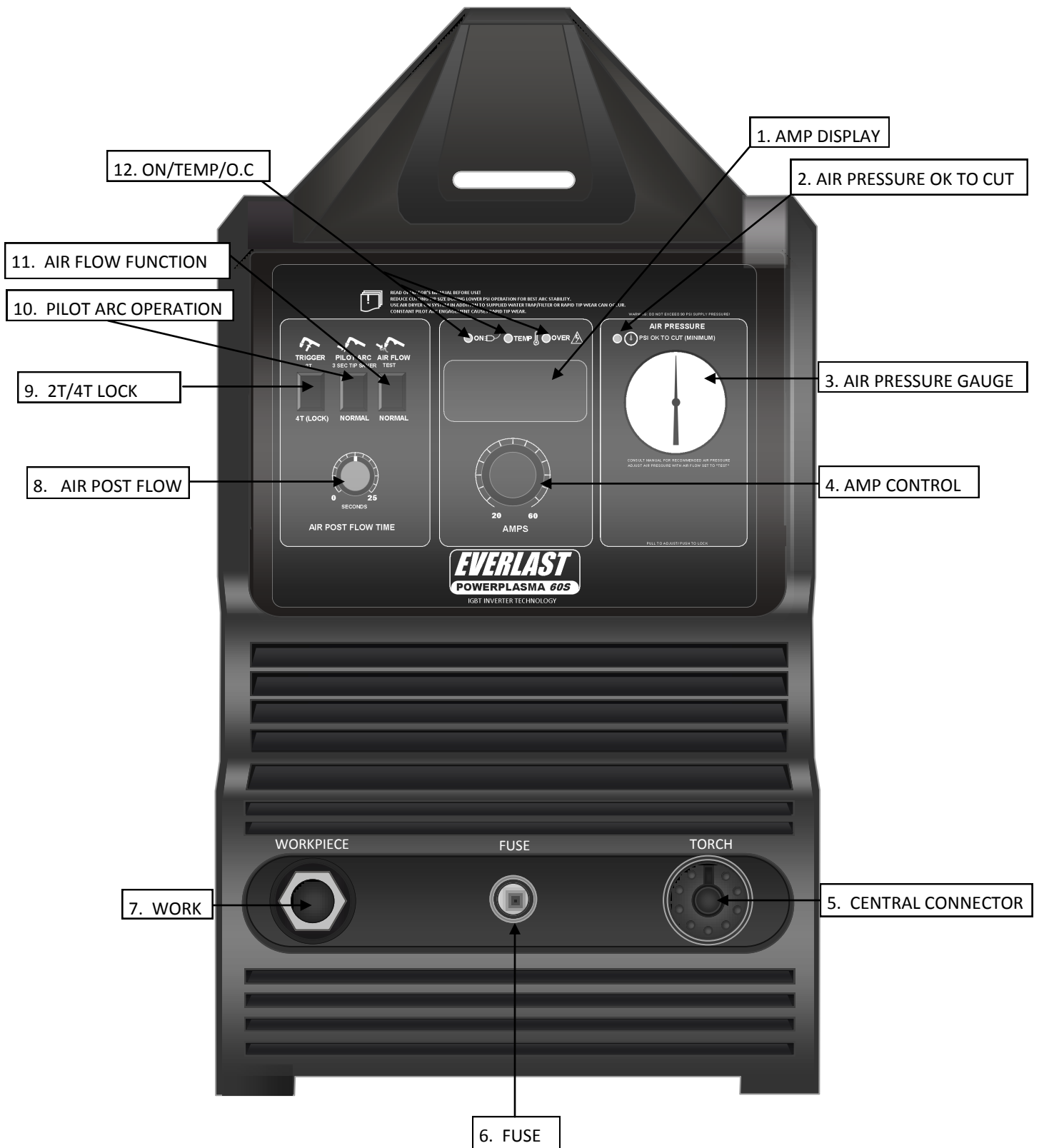

FRONT PANEL FEATURES AND CONTROLS CONTINUED

PowerPlasma S Features	PARAMETERS	PURPOSE
1. Amp Display	20-60 (60S) 20-70 (70S) 20-80 (80S)	Displays selected amperage until cut starts. Once cut starts, then amps display dynamically by displaying the actual output amps while cutting. While Pilot arc is engaged or when cut starts, the amps will drop to 20-30 amps until continuity is sensed and cutting arc takes over and the pilot arc disengages. Pilot arc is not designed to Cut. It should only be used to scour the surface, to gain continuity for the cutting arc.
2. Air Pressure OK to Cut LED	On/Off	This light should remain on as long as there is sufficient cutting pressure to protect the torch from melting. Once the air pressure drops below the minimum threshold of approximately 35 psi, the light will go out, indicating the pressure is too low. If the light goes out the unit will prevent the torch from being activated and there will be no power to the torch and the unit will not cut until the minimum air pressure is satisfied.
3. Air Pressure Gauge.	0-150 psi	The gauge registers up to 150 psi, but air pressure should never be set above 85 psi. Air pressure to the torch should be set at 70-75 psi. Ideal rated pressure by Trafimet is set at 72.5 psi.
4. Amp Control	Infinite	Adjusts and selects desired operating amperage.
5. Central Torch Connector	N/A	The central torch connector is an all-in-one connector. It is a universal connector and is available as part of the Trafimet OEM Torch connection. It greatly simplifies torch connection. When installing the connector, line up the tab on the male piece with the key hole slot on connector on the machine side. Insert the coupling fully and then tighten the collar nut on the torch fitting hand tight.
6. Fuse	2 A	This fuses the operating and display circuit of the unit so that it is protected from power surges and overloads. If the unit ceases to operate or the display will not work, check the fuse and replace it. This is a standard glass type automotive fuse which can be sourced locally. Do not use a higher rating than what the old fuse is rated for or damage can occur.
7. Work Piece Connector	N/A	The work lead (sometimes referred to as “ground”) is used to complete the circuit. The torch pilot arc may be active, but the unit will not actually cut if the work lead is not connected to the work piece. If an arc is present but the unit will not actively cut or is very slow or poor cutting any material, check and make sure work lead is connected and is connected to a clean spot on the work.
8. Air Post Flow	0-60	Select a post flow time that is appropriate to cool the torch and the consumables. Post flow time will depend upon the amps and length/severity of use. A post flow time of 3-5 seconds post flow for every 10 amps is suggested.
9. 2T/4T Trigger lock	2T/4T	2T is considered the normal method of operation for this torch. To operate, simply press and hold the switch and cut normally. Release the switch when the cut is finished. The 4 T setting allows the torch to be locked on during use. To use, place the switch in the 4T position. Then simply press and hold the trigger to start the arc. Release the trigger to continue cutting. Once the arc is ready to be terminated slowly press and release the switch again. Caution: When this feature can leave the torch activated if the torch is withdrawn from the cutting area.
10. Pilot Arc Function	3 sec/Normal	This allows the user to select for the best operation of the pilot arc to save consumables. The 3 second pilot arc engages the pilot arc for 2-3 seconds only before it shuts the arc off. To get the pilot arc to reactivate, the trigger will have to be pressed again. Normal mode allows the pilot arc to remain on and engage and disengage as needed.
11. Air Flow Function	Test/Normal	Select “Test” to set air flow/air pressure for the torch. The operating pressure should always be set while this is in Test since it does not ignite the pilot arc. This allows the air to flow constantly until the switch is placed back into the normal, timed mode. To set the air pressure, turn the torch until the nozzle is facing up, then place the flow tube (clear plastic tube with ball in it) over the nozzle. Select “Test” on the machine. With the air flowing, adjust the air pressure/flow up or down until the ball is floating in the sight window of the flow tube. If no flow tube is present or provided with your unit, then simply set the air pressure while “Test” is selected until it is somewhere between 70-75 psi. Pressure over or under this can result in an unstable arc.
12. On/ Temp/ Over Current	On or Off	These indicate the status of the machine and indicate if any fault is present. If duty cycle is exceeded, the Duty Cycle light will come on and cutting will be interrupted, but the unit will continue to run and the fan will cool. Once the light goes off cutting may resume. After 5-10 minutes, if the light does not go off and cutting is still prevented, the cycle the machine off and then back on. If the Over Current light is on, recheck all wiring and connections and make sure the correct wire size and wiring has been used. Purposefully creating too long of an arc may also cause this or it could be a side-effect of hitting the duty cycle limit of the machine. Cycle the machine on and off. If the light clears and cutting resumes, the fault has been cleared. If the unit will not work and/or the light remains on, contact Everlast Tech Support.

REAR PANEL FEATURES AND CONTROLS

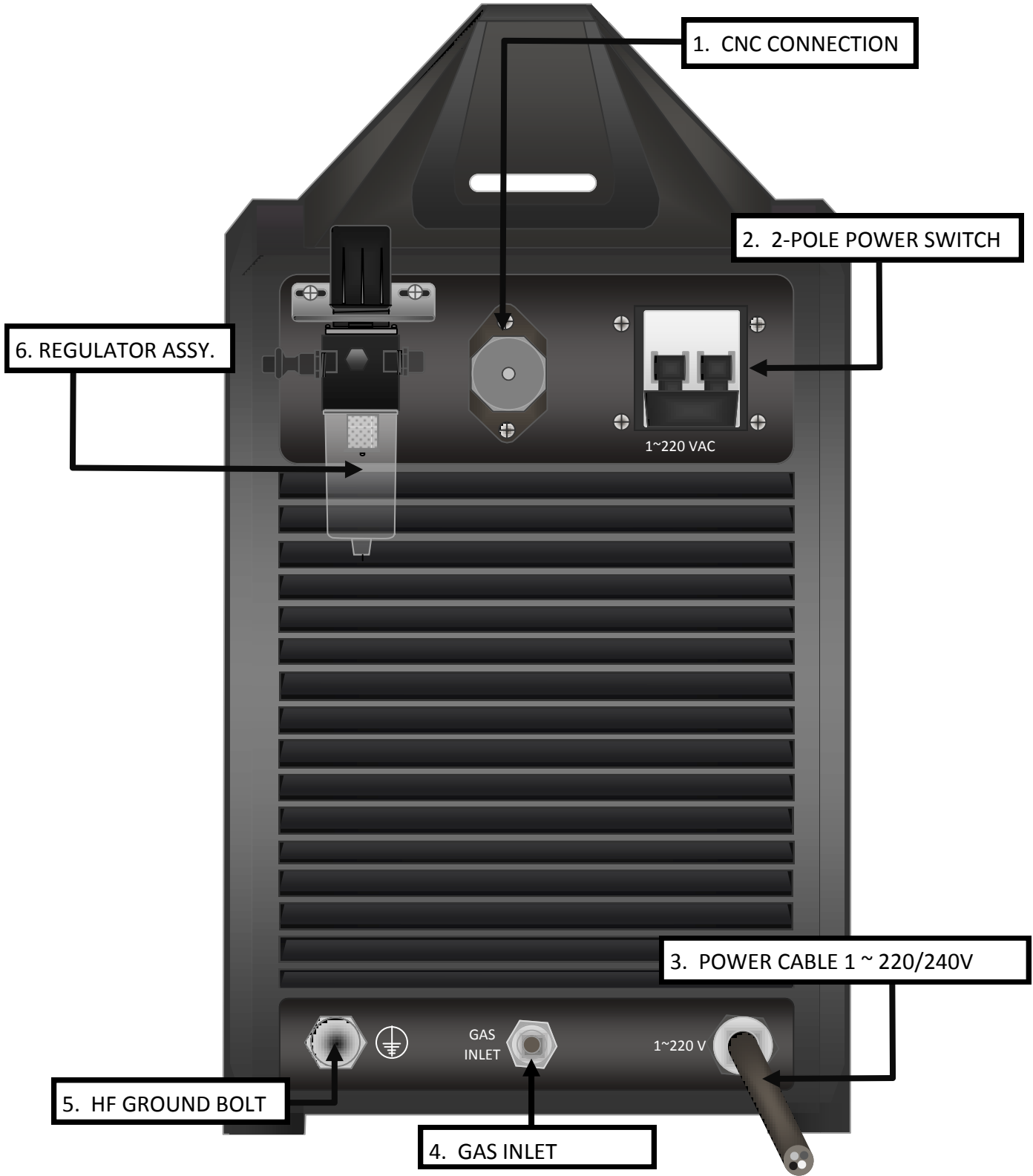

REAR PANEL FEATURES AND CONTROLS CONTINUED

FEATURE	PARAMETERS	PURPOSE
1. CNC Connection	N/A	This allows the unit to be used with a CNC machine and provides the basic inputs for CNC operation. See pin-out section located in the back of this manual.
2. 2-Pole Power Switch	On/Off	The breaker switch contains 2 poles for power. It serves as the On/Off switch for the cutter. Always turn the cutter on and off by the switch first before using any disconnect switch.
3. Power Cable	220/240 V 1 phase (110 X2)	The PowerPlasma S series uses 220/240 V power, including good quality 208 V power. The wiring contains 3 separate wires. Everlast uses standard wire color codes and sizes for welders plasma cutters. Standard wire colors are L-1 black (hot), L-2 white (hot), and green (ground) for 1 phase 220/240 V. Do not attempt to use a 4 wire 1 phase 220/240 connection. NOTE: In many home circuits, red and black are the power wires. But in standard welding/ plasma cutting circuitry, white and black are hot wires. Green is always the ground in both circuits. There is NO neutral in a standard welder circuit. The units are shipped with a standard NEMA 6-50P. Always consult a licensed electrician who is aware of local codes before attempting any wiring of the welder or of the power circuits. Everlast is not responsible for any mis-wiring or damage caused to the unit by incorrectly wiring the welder. If additional help is needed, contact Everlast. WARNING: DO NOT CONNECT THE PLASMA CUTTER TO ANY OTHER VOLTAGE OR PHASE, OR SEVERE DAMAGE WILL RESULT!
4. GAS Input Connection	Push to connect	The gas input line is connected to the Regulator assembly via the clear tubing provided in the accessory package. To attach, simply push the tubing into the connector until it is firmly seated then give a slight tug to make sure it has been captured correctly by the fitting. Make sure that the tubing shoulder is squarely cut and not cut at an angle. An uneven or angular cut will cause leaking at the connector. If the tubing must be removed, simply push on the outer plastic collar back while holding the tubing firmly in the other hand.
5. HF Ground Bolt	N/A	HF energy can be devastating to surrounding electronic equipment. Although this unit does not use HF energy to operate, it can serve as a direct drain should any EMF interference is suspected.
6. Regulator Assembly	N/A	The regulator assembly serves as both a filter/water trap, and an air regulator. The water trap with the fine sediment filter is self draining. It is not designed to dry the air, but rather serves the purpose of catching any residual slug of water that may be present in the air line and filtering any trash or sediment that passes into the bowl of the regulator. It is not designed to serve as an air dryer. A separate air dryer must be placed between the regulator and the air compressor. During the assembly of the regulator, be sure to screw the 1/4" automotive quick connect into the side that is stamped on top with "IN" or that has been stamped with an arrow pointing to the center of the regulator. The small brass plug should screw into the center of the regulator and the remaining push-to-connect fitting should be screwed into the remaining hole. Then, connect the clear tubing to the push-to- connect. Make sure the shoulder of the tubing has been cut squarely or the connection may leak as a result. Screw the regulator bracket to the back of the plasma cutter first before attaching the regulator to the bracket. Make sure the screws located in the accessory bag are the proper length and are inserted with the accompanying lock and flat washers. To adjust the regulator, simply pull the knob up slightly until it clicks, and rotate the knob clockwise to increase the pressure or counter clockwise to decrease the pressure. To lock in the setting, push the knob down until it clicks. Do not exceed 90 psi supply pressure. Do not exceed 85 psi on the plasma cutter side of the regulator or internal leakage may result. Operating air pressure should be set between 70 and 75 psi while in to "Test" mode.

1. Never operate the plasma cutter on a generator that is not certified by its manufacturer to be "clean" power, which is less than 10% total harmonic distortion. Less than 5% is preferred. Operating the unit on square wave output or modified sine wave generators is strictly prohibited. Contact the manufacturer of the generator for this information. Everlast does not have an "approved" list of generators. But, if the generator is not listed as clean power by its manufacturer, then operation is prohibited. Generators that do not at least meet the operating input requirements of the plasma cutter are also forbidden to be used with the welders. Surge amp capability of the generator should equal or exceed the maximum inrush demand of the plasma cutter. But the surge capability should not be used as the only factor. The regular, running output of the generator should match or exceed the running or "rated" demand of the welder. Any damage done by operating the unit on a generator not specified by its manufacturer to be "clean", will not be covered under warranty. This also includes suspect power sources where voltage is below 208 V and above 250 V.
2. To properly size the breaker, the I1MAX should be used in determining breaker size. To size the wiring, the I1EFF rating should be used to help determine the proper wire size. The NEC in Article 630.11 allows a derating of the wire size based off of duty cycle. The requirements are different than the requirements for most other 240V electrical products. However, consult a licensed electrician and local codes before installing any wiring or breakers.

SECTION 3

BASIC THEORY AND FUNCTION

The design of the blow back start *may* cause a slight delay in the arc as the air pressure must built inside the torch tubing and head to create the pressure needed to force the electrode off the nozzle seat. This may take up to two seconds. Restarting the arc with the post flow going may not cause a delay. If the torch does not light after 3 seconds, let go of the trigger and press it again. If start/arc is erratic check nozzle and electrode for tightness and wear.

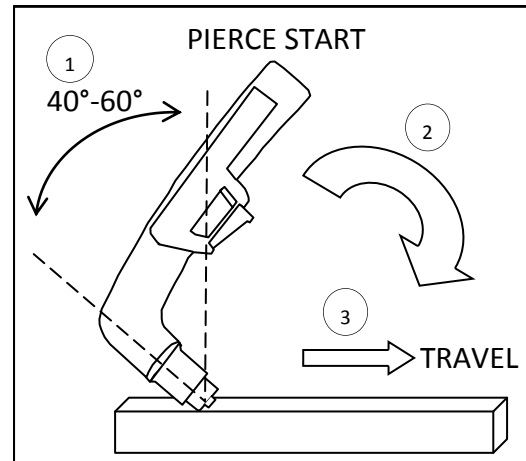
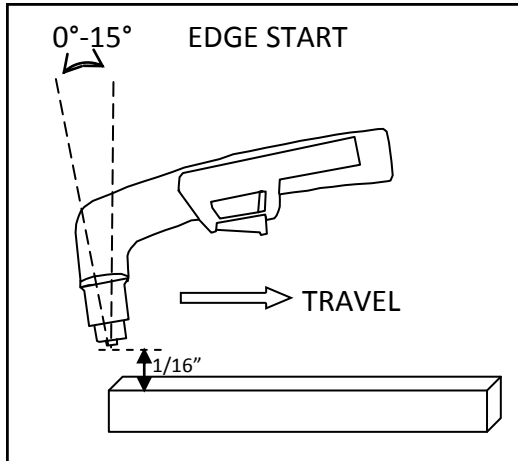

Edge Starts are the best type of start if possible to promote consumable and torch life. This reduces blow back of molten material and allows a smooth gradual start of the cut.

1. Line up the hole on the tip of the electrode on the edge of the cut. Hold torch perpendicular to the cut initially, about 1/16" off the metal. Slide the yellow safety lock and squeeze the trigger. Wait for arc to start.
2. Once the arc starts, wait for the arc to penetrate all the way through the metal.
3. As the torch penetrates its flame all the way through the metal, tilt the torch so there is a slight lead in the flame if metal is thin. If it is thick, keep holding torch in a nearly vertical position.
4. Begin moving the torch in the direction of the cut. Maintain 1/16" standoff height.
5. Move the torch fast enough so the sparks and flame trail from the bottom edge at an angle of no more than 30° and no less than 10° from perpendicular to the metal. Excess angle of sparks/flame indicate too fast of travel speed or practical cut capacity has been reached. Little or no angle indicates too slow of travel speed.

Piercing starts often result in rapid consumable wear and excess blow back of molten metal deposited onto torch and consumables. This should be done only as necessary.

1. Tilt the torch in the direction of travel or toward the side of the metal to be discarded or wasted at a 40° to 60° angle. Slide the yellow safety lock and squeeze the trigger. Wait for arc to start.
2. Once the arc starts, wait for the arc to transfer from pilot arc to the cutting arc.
3. As the torch penetrates it flame at an angle rotate the torch slowly to the vertical position, as the arc penetrates the metal. Tilt the torch from 0°-15° for thin metal cuts, or hold it nearly perpendicular for thicker metal cuts.
4. Begin moving the torch in the direction of the cut. Maintain 1/16" standoff height.
5. Move the torch fast enough so the sparks and flame trail from the bottom edge at an angle of no more than 30° and no less than 10° from perpendicular to the metal. Excess angle of sparks/flame indicate too fast of travel speed or practical cut capacity has been reached. Little or no angle indicates too slow of travel speed.

IMPORTANT: If you use a standoff guide with the torch, it must be adjusted or bent to provide no more than 1/8" standoff, less if possible. Long standoff heights reduce cut capacity and quality. It also promotes rapid consumable wear and can prevent the pilot arc from transferring.

TIP: For longer consumable life do not use the pilot arc unnecessarily. Select the 3 second pilot arc feature and do not fire the torch unless you are near the metal and ready to cut. For expanded metal cutting be sure to select "Normal" to re-fire the pilot arc automatically.

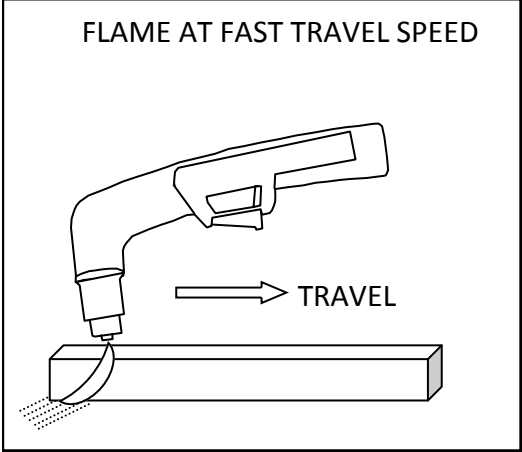
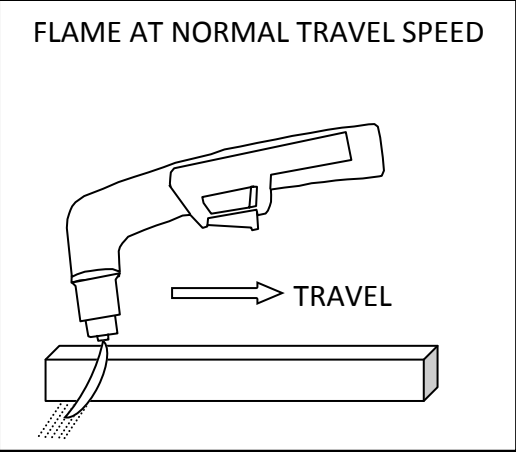

15-30

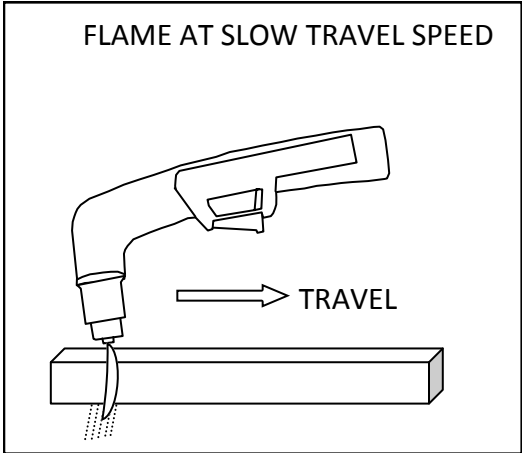

NOTE: When stepping down amps to cut thinner material, you must change to smaller orifice nozzle. Nozzles are offered through Trafimet in different sizes which are appropriate for different amp levels. Too large of a diameter orifice will result in arc instability and a rough cut. Lowering the air pressure below 65 psi to try to get the torch to cut will only result in a lazy, wandering arc.

IMPORTANT: Check consumables regularly for wear and change them out before they are completely worn. Allowing the consumables to wear until they quit working may damage related torch components, creating a more costly repair.

**RESULTS OF CUT AT CORRECT SPEED,
AIR PRESSURE AND TORCH ANGLE**
SMOOTH, EVEN CUT LINES WITH A S REARWARD SWEEP

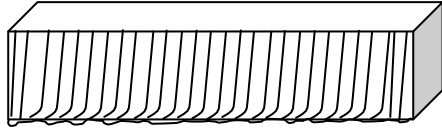

MINIMAL EASY TO CLEAN DROSS

RESULTS OF CUT AT FAST SPEED
ROUGH, DISTINCT CUT LINES SPACED FAR APART

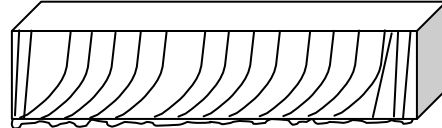

NOTICEABLE SMALL, HARD DROSS

RESULTS OF CUT AT SLOW SPEED
VERTICAL CUT LINES



SIGNIFICANT SOFT, POROUS DROSS

**RESULTS OF TOO MUCH CURRENT OR
TOO MUCH STAND OFF HEIGHT
(SIDE VIEW)**
MELTED TOP EDGE

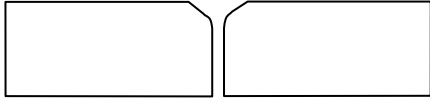

**RESULTS OF WORN CONSUMABLE OR
LOW AIR PRESSURE
(SIDE VIEW)**
SEVERLY ANGLED CUT AT TOP

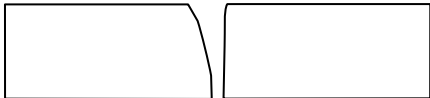

AN EXAMPLE OF CUTTING A LEAD-IN WHEN CUTTING OUT A DISK SHAPED OBJECT

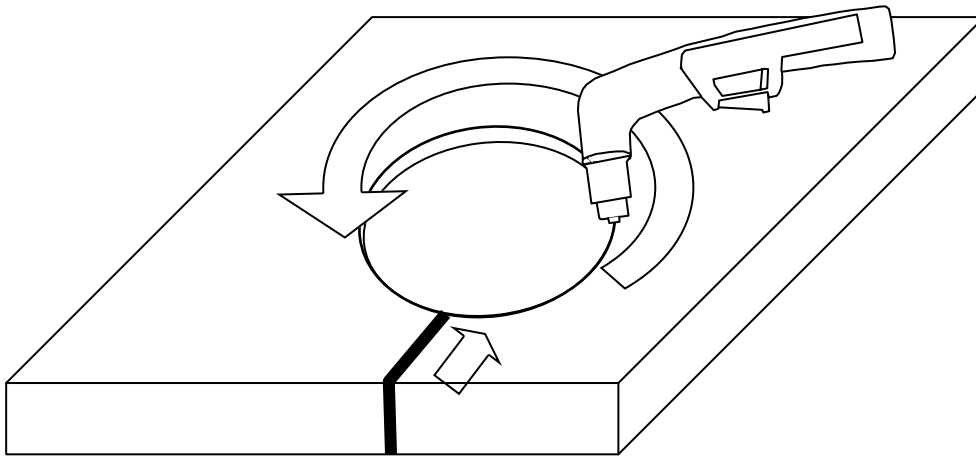

AN EXAMPLE OF CUTTING A LEAD-IN WHEN CUTTING HOLE IN AN OBJECT

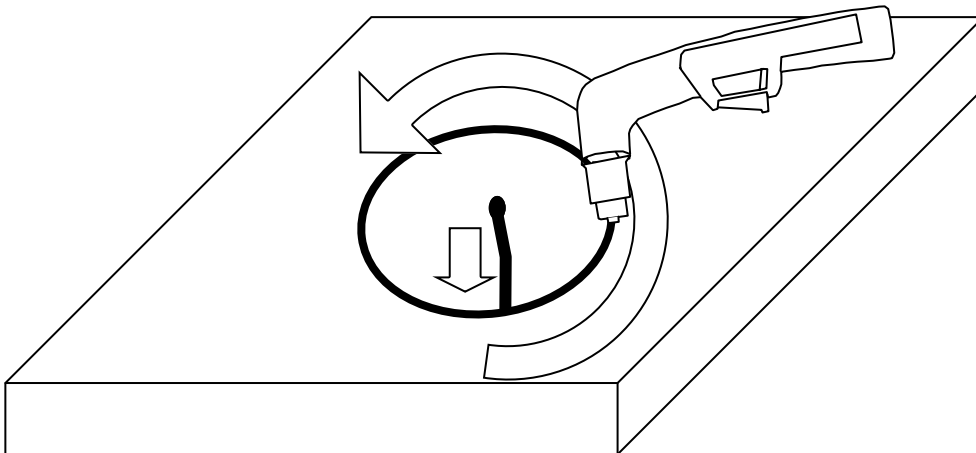

When cutting an object, particularly a pattern shape, where the torch must pierce or re-fire in-line at an intersection of a cut, a lead-in cut should be employed. A lead-in is a cut that is made in the disposable part (also known as a drop) of the object to "lead" into the main part of the cut so that the destructive force of the arc is not directed into the desirable side of the cut itself. Also, all plasma cutters exhibit some angularity or bevel in the cut which is greater on one side than the other. Keep this in mind when cutting an object to size so that too much metal is not accidentally removed.

ERGOCUT S 75
PLASMA RANGE



TECHNICAL DATA

Voltage class	M
Standard length m	6
Air consumption	150 l/min
Air pressure	5 bar
Duty cycle 60%	70 A
Duty cycle 100%	50 A

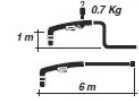

	S 75	m
FITTING	PA1606	6
SIZE	PA1602	6
FITTING	PA1602	6
SIZE	PA1604	6

DECLARATION OF CONFORMITY
The undersigned company Trafimet - Via del Lavoro, 9 - 36020 Castegnero (VI) - Italy - declares that the product identified and described on this page complies with standard EN 60974-7 in accordance with the requirements contemplated by directive EEC 73/23 low voltage.



trafimet[®]
your welding partner



ERGOCUT S 75
PLASMA RANGE

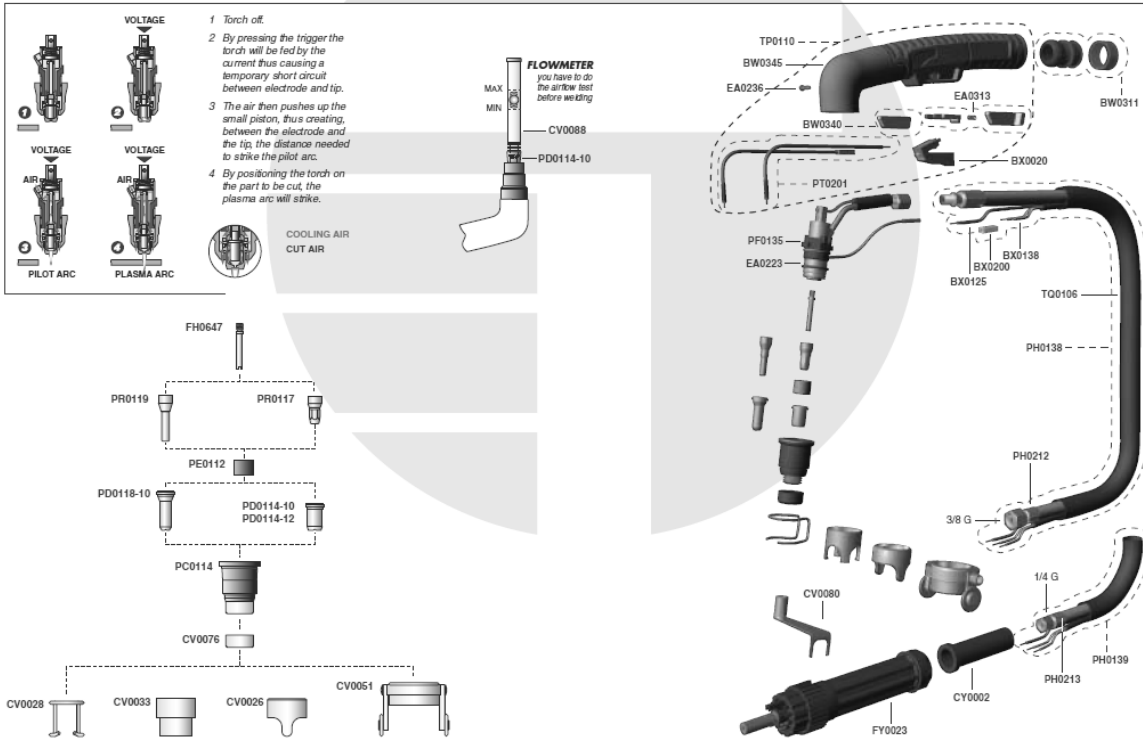

*Everlast is not the manufacturer of the Trafimet S-75 torch, nor is it affiliated with Trafimet other than its role as an OEM supplier of torches on PowerPlasma S-Series units. Not all items, accessories and parts depicted are available directly through Everlast. These are items supplied through nationwide Trafimet dealers and resellers. Diagram provided courtesy of Trafimet.

CNC CONNECTOR PIN-OUT

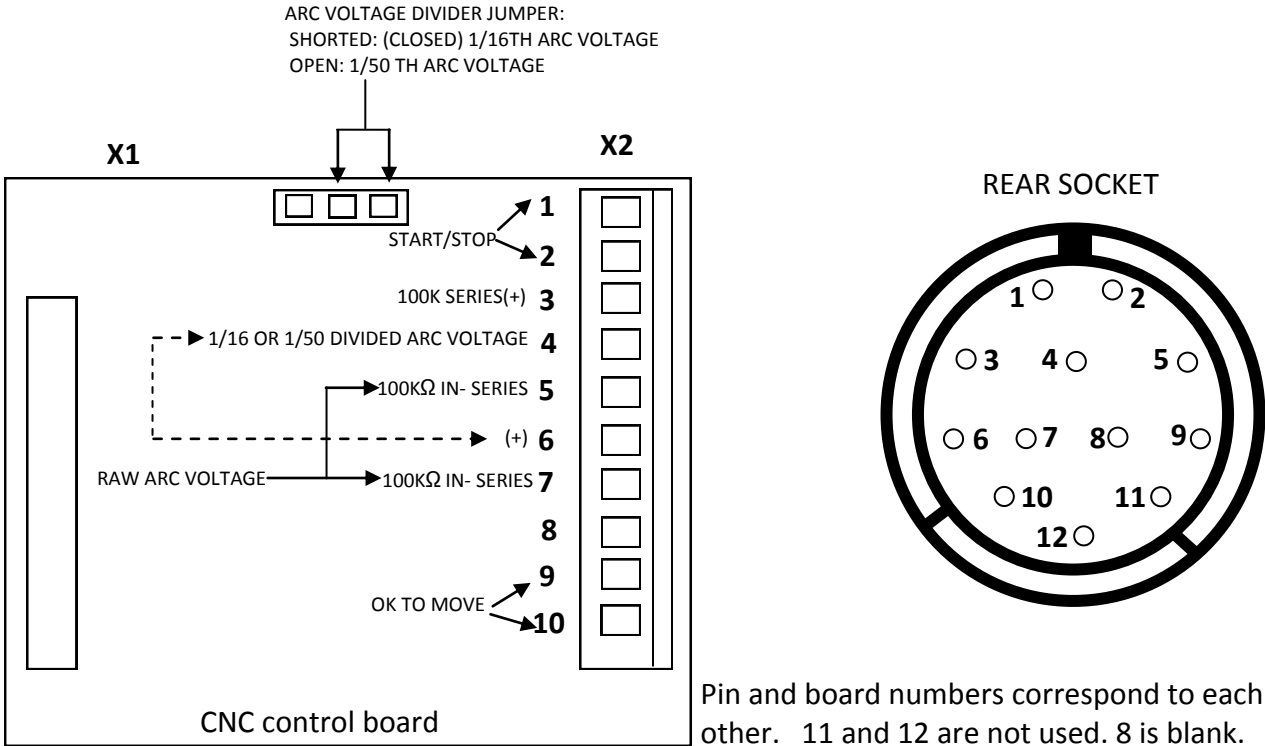

Pins 1 and 2 activate (turn on) the plasma cutter.

Pins 9 and 10 gives the “OK to Move” signal. These are Dry “N.O.” style contacts. It is a non electronic switch that **closes** when the pilot arc transfers to cutting arc. Sometimes referred to as “Arc OK”.

Pins 5 and 7 provide the raw, undivided arc voltage, which is used by some controllers to adjust the height of the torch (THC). This is the actual cutting voltage. It runs through 2 -100KΩ resistors to prevent arcing at the connector plug. Some controllers may use the raw voltage, and is dependent upon the impedance of the input. CandCNC* controller and Torchmate * do not use this voltage.

Pins 4 and 6 provide the divided arc voltage. This is selectable by adding a jumper on the CNC circuit board to create either 1/16 th or 1/50th of the raw arc voltage. It may be used by some controllers for torch height control (THC). Usually the 1/16 setting is preferred.

Pin 3 is what some controller manufactures refer to as “Ground” this is connected directly to the work piece lead, which is actually a positive polarity. If the controller has a pin for ground this is likely the pin to use.

NOTE: Do not connect anything directly to the output terminals or leads. Do not connect anything from the controller to the chassis of the cutter, especially a ground lead. Do not install any kind of converter or divider inside the machine.

*Everlast does not particularly endorse or recommend these brands and is not affiliated with them in anyway. They are mentioned as a common reference only. For specific recommendations regarding connection, contact the manufacturer of the CNC equipment/controllers.

TROUBLE:	CAUSE/SOLUTION
Machine will not turn on. No fan, no display.	Check cords and wiring in the receptacle. Check circuit breaker. Check plug condition.
Air Flows but arc does not start withing 2-3 seconds.	Check consumables for wear and tightness. Check fuse. Check Air Pressure. Sticky or slow spring/piston on torch blow back mechanism. Release trigger and try again.
Air Flows but arc does not start or spark when nozzle is rubbed on the metal.	Fuse blown. IGBT issue. PCB issue.
OK to cut light is not on. Will not start arc.	Increase air Pressure. Make sure air is connected.
Pilot arc will not light.	Fuse blown.
Pilot arc will not transfer and amps read approximately 25-27 amps while switch is held. (Arc barely cuts or only “scratches” the surface of the metal or cut is extremely slow on thin materials.	Check work clamp connection. Make sure rust is removed from work clamp contact area. Faulty Clamp. Arc continuity is not being sensed. If these steps do not correct the issue, contact Everlast.
Arc Sputters.	Inadequate air flow or air pressure. Improperly sized nozzle. Decrease size as amps are lowered. Increase air pressure to 73 psi while air is flowing through torch. Loose consumables. Check tightness.
Consumables are dirty, smutty looking upon inspection. Premature wear on consumables. Shortened consumable life.	Moisture, oil contamination of consumable. Wrong consumables. Poor quality aftermarket consumables.
Premature wear on consumables. Short consumable life. Uneven wear of consumables, melting of cup.	Moisture, oil contamination of consumable. Excessive pilot arc time. Improper cutting technique. Wrong piercing technique.
Arc will not start. Air will not flow. Machine runs.	Torch cup is loose, safety contact pins dirty or not making contact with cup face. Torch switch wire is loose. Problem with Central connector. Torch is not properly connected.
Over current/Duty cycle LED illuminates. Machine runs, but no output.	Duty cycle exceeded or Over current. Allow machine to cool. Reset main power switch after full cool down period. Make sure fan is not blocked. Check wiring.
Unstable Arc at lower amps.	Consumable orifice size is too large. Reduce orifice size.
Arc tries to start but irregular, dancing arc and/or arc melts through side of nozzle.	Missing swirl ring, or worn electrode or both. Check and replace. Make sure swirl ring is not cracked.
Arc will try to start if touched to the metal, but no air flow while switch is pressed.	Stuck or dirty solenoid valve. Contact Everlast.
Air flows continuously.	Place switch into “normal” or “cut” mode. Turn down post flow time. Solenoid is stuck. Contact Everlast.
Excessively Beveled Cut.	Worn consumables, too high of stand-off height.
Cup and/or nozzle is melting or cracking.	Improper cutting technique/excessive piercing.
Power input circuit breaker trips repeatedly.	Improperly sized circuit. Internal issue. Contact Everlast.
Arc “Blows Out” when ready to cut.	Too high of air pressure. Reduce to 72 psi.

