

Owner's Manual

POWERTEC

12-1/2" THICKNESS PLANER

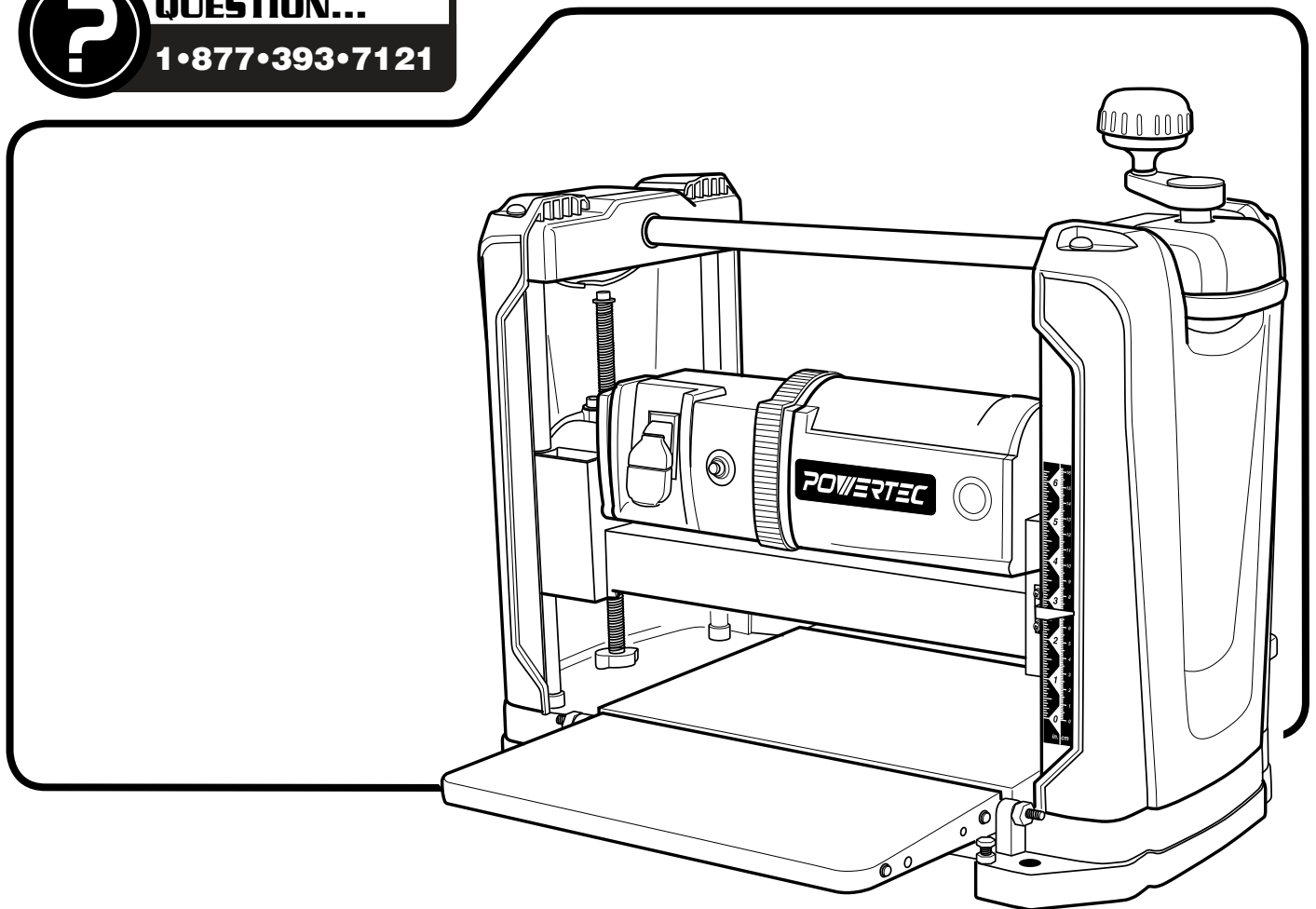

Visit us on the web at www.southerntechllc.com

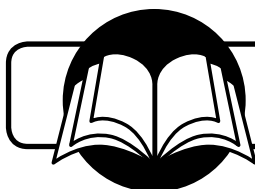

You will need this manual for safety instructions, operating procedures, and warranty. Put it and the original sales invoice in a safe, dry place for future reference.

TABLE OF CONTENTS

SECTION PAGE

SAFETY RULES 1

Work Preparation
Work Area Preparation
Tool Maintenance
Tool Operation

ASSEMBLY 2

Unpacking
Install Dust Chute
Install Elevation Crank Handle
Power Source
Grounding Instructions
Extension Cords
Electrical Connections

OPERATION 5

Safety Precautions
Rollercase Height Adjustment
Depth of Cut
ON/OFF Switch
Circuit Breaker
Before Operating the Planer
Operate the Planer

MAINTENANCE 8

Check and Replace the Blades
Inspect and Replace the Motor Brushes
Adjust Rollercase Level
Replace V-Belt
Clean and Lubrication

TROUBLESHOOTING 10

PARTS ILLUSTRATION & LIST 12

WARRANTY 14

PRODUCTION SPECIFICATIONS

Horsepower (Maximum Developed).....	2 HP
Voltage.....	120 V
Amperes.....	15 A
Hertz.....	60 Hz
Phase.....	Single
Motor RPM.....	17,500 RPM
Table Size.....	12-1/2"×9-5/16"
Blade Width.....	12mm
Maximum Depth of Cut.....	3/32"
Cuts per Minute.....	18,800

MOTOR SPECIFICATIONS

Planer is supplied with a 2 HP motor installed. The 120 Volt AC universal motor has the following specifications:

Horsepower (Maximum Developed)	2 HP
Voltage	120
Amperes	15
Hertz	60
Phase	Single
Cutterhead RPM	9,400

SAFETY RULES

1

⚠ WARNING

For your own safety, read and understand all warnings and operating instructions before using any tool or equipment.

⚠ WARNING

Some dust created by the operation of the power tool contains chemicals known to the State of California to cause cancer, birth defects or other reproductive harm. To reduce your exposure to these chemicals, work in a well ventilated area and work with approved safety equipment. Always wear OSHA/NIOSH approved, properly fitting face mask or respirator when using such tools.

⚠ WARNING

Failure to follow these rules may result in serious personal injury. Remember that being careless for even a fraction of a second can result in severe personal injury.

WORK PREPARATION

- Wear proper apparel. Do not wear loose clothing, gloves, neckties, rings, bracelets or other jewelry which may get caught in moving parts of the tool.
- Nonslip protective footwear is recommended.
- Wear protective hair covering to contain long hair.
- Wear eye and hearing protection. Always use safety glasses. Eye protection equipment should comply with ANSI Z87.1 standards. Hearing equipment should comply with ANSI S3.19 standards.
- Wear face mask or dust mask if operation is dusty.
- Be alert and think clearly. Never operate power tools when tired, intoxicated or when taking medications that cause drowsiness.

WORK AREA PREPARATION

- Keep work area clean. Cluttered work areas and benches invite accidents.
- Work area should be properly lighted.
- Do not use the machine in a dangerous environment. The use of power tools in damp or wet locations or in rain can cause shock or electrocution.
- Three-prong electrical plug should be plugged directly into properly grounded, three-prong receptacle.
- Use a proper extension cord. Make sure your extension cord is in good condition and should have a grounding prong and the three wires of extension cord should be of the correct gauge.
- Keep children and visitors away. Your shop is a potentially dangerous environment. Children and visitors can be injured.
- Make your workshop childproof with padlocks, master switches or remove switch keys to prevent any unintentional use of power tools.

TOOL MAINTENANCE

- Turn the machine "OFF", and disconnect the machine from the power source prior to inspection.
- Maintain all tools and machines in peak condition. Keep tools sharp and clean for best and safest performance.
- Follow instructions for lubricating and changing accessories.
- Check for damaged parts. Check for alignment of moving parts, binding, breakage, mounting and any other condition that may affect tool's operation.
- Poorly maintained tools and machines can further damage the tool or machine and/or cause injury.
- A guard or any other part that is damaged should be repaired or replaced. Do not perform makeshift repairs.

TOOL OPERATION

- Avoid accidental start-up. Make sure that the tool is in the "OFF" position before plugging in.
- Use the right tool for your job. Do not force your tool or attachment to do a job for which it was not designed.
- Disconnect tool when changing parts.
- Don't force the workpiece on the machine. Damage to the machine and/or injury may result.
- Never leave tool running unattended. Turn the power off and do not leave tool until it comes to a complete stop.
- Do not overreach. Loss of balance can make you fall into a working machine, causing injury.
- Never stand on tool. Injury could occur if the tool tips, or if you accidentally contact the cutting tool.
- Know your tool. Learn the tool's operation, application and specific limitations before using it.
- Use recommended accessories. Use of improper accessories may cause damage to the machine or injury to the user.
- Handle workpiece correctly. Keep hands away from moving parts.
- Turn tool off if it jams.

CAUTION: Think safety! Safety is a combination of operator common sense and alertness at all times when tool is being used.

⚠ WARNING

Do not attempt to operate tool until it is completely assembled according to the instructions.

UNPACKING

- Check for freight damage before opening the package. If freight damage is noticed, file a claim with the carrier immediately.
- Check to ensure all parts are accounted for. If any parts are missing, please contact the customer service center at 1-877-393-7121.
- This Planer comes mostly assembled. It requires some additional assembling, installation, and adjustment before use.
- Locate the following parts before assembling:

- A. Planer
- B. Elevation Crank Handle Assembly (including M5 bolt, flat washer and plug)
- C. Magnet (2)
- D. T Wrench

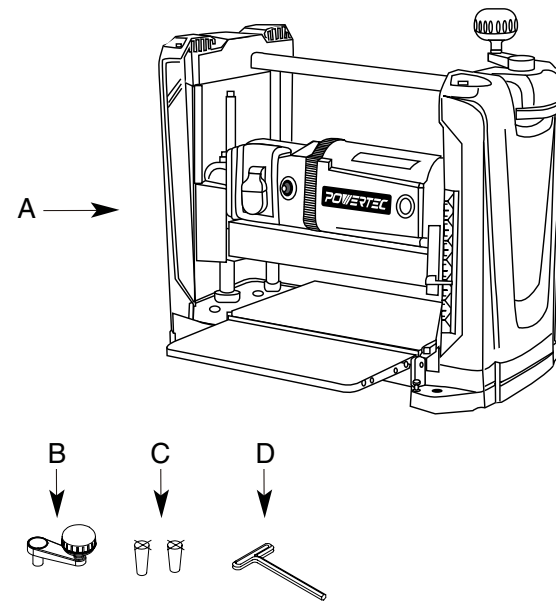
Figure 1 Unpacking**INSTALL ELEVATION CRANK HANDLE**

Refer to Figure 2 and 3

- The planer handle can be installed to the top-right of the planer.
- Insert handle onto elevation screw top.
- Secure handle with bolt and flat washer using the enclosed wrench.
- Insert plug into handle

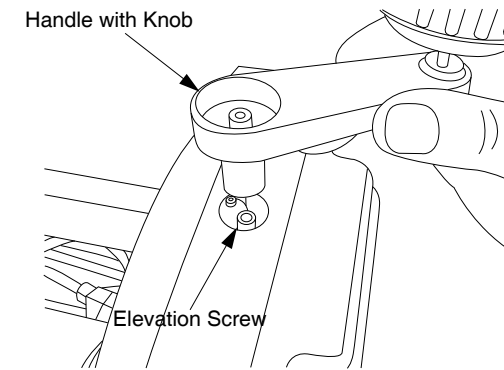
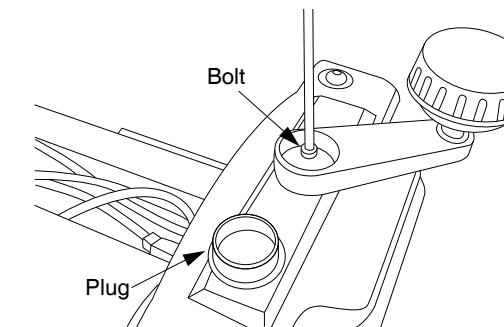
Figure 2 - Install Handle**Figure 3 - Secure Handle****WARNING**

Do not use the machine until it is completely assembled and you have read and understood the entire operating manuals.

- The machine must be installed in a well-lit area with correct power supply.
- There must be enough clearance for the moving workpiece during operation. There must be enough room for safe operation of the machine.

POWER SOURCE**WARNING**

Do not connect to the power source until the machine is completely assembled.

The machine is wired for 120 Volts, 60 Hz alternating current. Before connecting the machine to the power source, make sure the switch is in the "OFF" position. Running the unit on voltages which are not within range may cause overheating and motor burn-out. Heavy loads require that voltage at motor terminals be no less than the voltage specified on nameplate.

- Power supply to the motor is controlled by a locking rocker switch. Remove the key to prevent unauthorized use.

GROUNDING INSTRUCTIONS**WARNING**

Improper connection of equipment grounding conductor can result in the risk of electrical shock.

- The machine should be grounded while in use to protect operator from electrical shock.
- In the event of an electrical short circuit, grounding reduces the risk of electrical shock by providing an escape wire for the electricity.
- This machine is equipped with an approved 3-conductor cord rated at 120V and a 3-prong grounding type plug (Figure 4) for your protection against shock hazards.
- Grounding plug should be plugged directly into a properly installed and grounded 3-prong grounding-type receptacle, as shown (Figure 4).
- The plug must be plugged into an outlet that is properly installed and grounded in accordance with all local codes and ordinances.
- Check with a qualified electrician or service personnel if these instructions are not completely understood or if in doubt as to whether the tool is properly grounded.
- Do not modify plug provided. If it will not fit in outlet, have proper outlet installed by a qualified electrician. Use only 3-wire extension cords, that have 3-prong grounding type plugs and matching 3-conductor receptacles that accept the machine's plug, as show in Figure 4.

Figure 4 - 3-Prong Receptacle

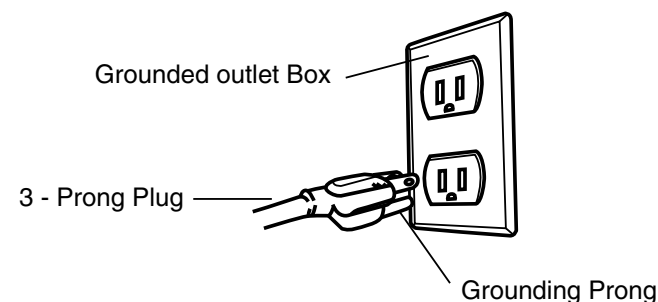
**WARNING**

Do not permit fingers to touch the terminals of plug when installing or removing from outlet.

- Inspect tool cords periodically, and if damaged, have repaired by an authorized service facility.
- The conductor with insulation having an outer surface that is green with or without yellow stripes is the equipment-grounding conductor. If repair or replacement of the electric cord or plug is necessary, do not connect the green (or green and yellow) wire to a live terminal.

A temporary 3-prong to 2-prong grounding adapter (see Figure 5) may be used to connect this plug to a matching 2-conductor receptacle as shown in figure 5. The temporary adapter should be used only until a properly grounded outlet can be installed by a qualified electrician.

Figure 5 - 2-Prong Receptacle

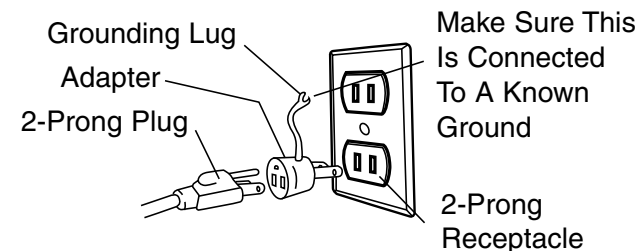

In Canada, the use of temporary adapter is not permitted by the Canadian Electric Code. Where permitted, the rigid green tab or terminal on the side of the adapter must be securely connected to a permanent electrical ground such as a properly grounded water pipe, a properly grounded outlet box or a properly grounded wire system.

- Many cover plate screws, water pipes and outlet boxes are not properly grounded. To ensure proper ground, grounding means must be tested by a qualified electrician.

EXTENSION CORDS

Use proper extension cords. Make sure the extension cord is in good condition. Use only 3-wire extension cords that have 3-prong grounding type plugs and 3-pole receptacles which accept the tool plug. When using an extension cord, make sure to use one heavy enough to carry the current of the machine. An undersized cord will cause a drop in the voltage, resulting in loss of power and overheating. Use the table to determine the minimum wire size (A.W.G.) extension cord.

Extension Cord Length

Wire Size	A.W.G.
Up to 25 ft.	18
25 to 50 ft.	16

NOTE: Using extension cords over 50 ft. long is not recommended.

ELECTRICAL CONNECTIONS**WARNING**

- Turn the switch off and disconnect the machine from power source before performing any repair or maintenance work.
- Some electrical wiring and connection work must be performed by a qualified electrician in accordance with local regulations.
- There is a green grounding wire fastened to the frame of the machine to provide shock protection. Do not disconnect the grounding wire from the frame.
- The motor is rated for used at 120 Volts.
- Connect this machine to 3-Conductor power outlet with appropriate rating only.
- Use only 3-pronged extension power cord with appropriate rating with this machine.
- When changing the power cord, use only 3-pronged power cord with appropriate rating.
- The power switch is a single pole rocker switch with locking mechanism. Remove the key when not in use to prevent accidents.

OPERATION**WARNING**

For our own safety, read the entire operating manual and safety instructions before using this tool.

SAFETY PRECAUTIONS

- Be aware of general power tool safety. Make sure all the safety rules are understood.
- Disconnect the machine from power source whenever adjusting or replacing any parts.
- Do not plug planer in unless switch is in the "OFF" position.
- Keep hands away from all moving parts.
- Wear eye protection or face shield during operation.
- Make sure all mobile parts move freely and are free from interference.
- Keep blades sharp, aligned and properly attached cutterhead.
- Properly secure the blades in the cutterhead.
- Never turn the machine "ON" with the workpiece contacting the cutterhead.
- Never make cuts deeper than 3/32" (2.4mm) to prevent kickback.
- Do not force cut. Slowing or stalling will overheat the motor.
- Do not perform planing on workpiece shorter than 15", narrower than 3/4", wider than 12 1/2" or less than 1/8" thick.
- Properly support long or wide workpieces.
- Do not use a workpiece that is warped, contains knots, or is embedded with foreign objects (nails, staples, etc) to prevent kickback.
- Do not feed a workpiece into the planer outfeed table.
- Do not allow anyone to stand or cross in line of cutterhead rotation. Kickback or thrown debris will travel in this direction.
- Turn switch off and disconnect power whenever planer is not in use.
- Keep planer maintained. Follow maintenance instructions.

ROLLERCASE HEIGHT ADJUSTMENT

Refer to Figure 6

- Roller case is the centerpiece of the planer machine. It contains motor, cutterhead with blades, infeed and outfeed rollers, dust collection assembly.
- The roller case can be moved up or down precisely by rotating the elevation crank handle on the top of planer. One complete turn of elevation crank handle is equivalent to 1/16" movement of roller case in either direction.

- There is an elevation scale at the front of right side panel. It has a pointer with English and Metric scale. The reading is the height of cutterhead from the table platform. Therefore, the elevation scale setting represents the approximate thickness of the workpiece after planing.
- Elevation scale is calibrated in factory and should have reasonable accuracy. For woodworking of precision, use of calipers after each planing is recommended.

Figure 6

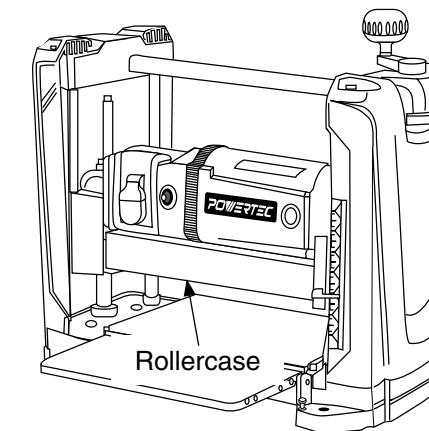
**DEPTH OF CUT**

Refer to Figure 6

- The depth-of-cut is the thickness of wood material removed from the surface of workpiece during each pass. The depth-of-cut is determined by the relative position of the roller case to the top of workpiece.
- To protect long use life of motor and cutterhead unit, the recommended maximum depth-of-cut are:
3/32" for workpiece up to 5" wide
1/16" for workpiece from 5" to 12 1/2" wide

ON/OFF SWITCH

Refer to Figure 7 and 8

The ON/OFF switch is located on the front of planer. To turn the machine ON, pull the switch to the up position. To turn the machine OFF, push the switch to the down position.

NOTE: When the machine is not in use, the machine should be locked in the "OFF" position to prevent unauthorized use.

- To lock the machine, turn the switch to the "OFF" position. Pull the key out. The switch cannot be turned on without the key.
- If the key is removed when the switch is at the "ON" position, the switch can be turned off but cannot be turned on again.
- To unlock, place the key into the slot on switch unit until it snaps.

Figure 7 – ON/OFF Switch

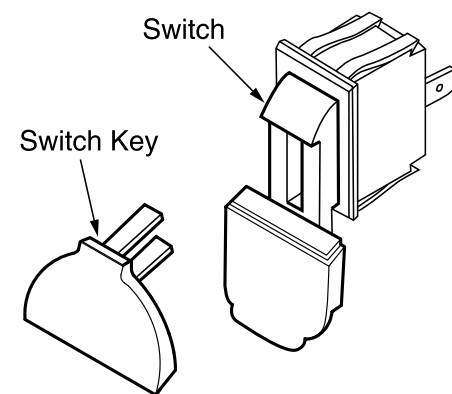
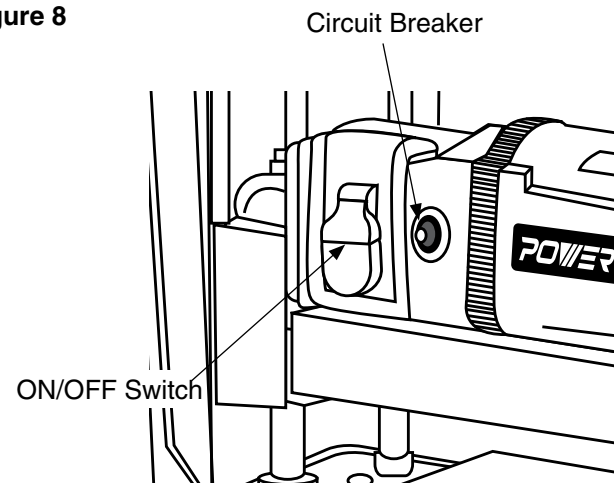

Figure 8



CIRCUIT BREAKER

Refer to Figure 8

- This machine has a circuit breaker installed next to the main power switch. The circuit breaker protects the motor unit by shutting off the power supply when excessive electric current is detected. If the circuit breaker is tripped, the machine will not power on.
- Before resetting the circuit breaker, check motor, switch, and line connection for short circuit or faulty components.
- To reset the circuit breaker, Turn the switch to "OFF"

position. Then press the circuit breaker reset button next to the main switch.

BEFORE OPERATING THE PLANER

- Understand the machine function and observe all the safety measurement.
- In general, the desired depth-of-cut and final thickness of workpiece are determined before planing. Since there is limit of maximum depth-of-cut, the workpiece may have to pass the machine several times before reach the desired final thickness.
- The roller case has to be lowered manually before each pass, if more than one pass is necessary.
- The planer machine setting involves readings of elevation scale and operation of the roller case elevation crank handle.
- The roller case elevation crank handle controls roller case position in height and determines the amount of wood material to be removed (depth-of-cut) in each pass. Thickness of the remaining workpiece, after planing (final thickness), is observed in elevation scale.
- In general, thin depth-of-cut produces better outcome: smooth surface, even thickness, less kickback, less snipe, even thickness, less wear on cutterhead and motor.
- Set thin depth-of-cut for hardwood, wide workpiece, and uneven surface.
- This planer machine is designed to process natural wood material only.
- Remove glue and any foreign objects from the workpiece before planing.
- Avoid wood stock with many or large knots.
- Avoid wood stock with excessive twisting, cupping, or bowing.
- If necessary, process one side with jointer machine first to obtain at least one flat surface before using the planer machine.
- For better outcome, plane both sides of wood board with 1/2 of depth removed from each side. This will produce two smooth surfaces with equal amount of moisture content. The board is less likely to warp when it dries naturally.
- Test cut with similar wood material for better accuracy.
- The Minimal length of workpiece that can be processed is 15". The minimal width is 3/4". The minimal thickness is 1/8". (This is not to be confused with depth-of-cut.)
- The maximal width of workpiece that can be processed is 12 1/2". The maximal thickness is 6".
- To protect long use life of motor and cutterhead unit, the recommended maximum depth-of-cut are:
3/32" for workpiece up to 5" wide
1/16" for workpiece from 5" to 12 1/2" wide
- Use additional roller stand for workpiece longer than 24".

OPERATE THE PLANER MACHINE

- Always use protective safety wear and observe safety rules.
- Never stand directly in the pathway of the workpiece, including infeed and outfeed, to avoid injury. The operator should stand on the side of the elevation crank handle.
- Feed the workpiece "WITH The Grain" as much as possible. That is, at the contact point, the grain points to the same direction as that of rotating cutterhead. For this planer machine, the grain direction on the top of workpiece should point toward the front of the machine.
- Place the workpiece on the infeed table. The surface to be planed should be faced up.
- With the planer properly set up, turn the machine on.
- Hold the workpiece firmly and advance toward the infeed roller slowly.

- Stop pushing or pulling the workpiece once it is engaged by the infeed roller.
- The infeed roller will move the workpiece automatically through the planer.
- For long workpiece, gently support the weight of the workpiece while it is moved into and out of the planer to stabilize the workpiece and decrease snipe.
- Move to the back of machine to receive the workpiece. Do not pull.
- Use the return roller on top of planer to help transport big workpiece back to infeed side.
- Use the entire width of the cutterhead to avoid uneven wear of knives.
- For precision woodworking, measure thickness with calipers after each planing.

WARNING

Turn the switch to the OFF position and disconnect the machine from power source before any maintenance.

CHECK AND REPLACE THE BLADES

Refer to Figure 9 and 10

- Locate the blade cover on the back of planer. Loosen and remove thumb screws from blade guard.
- Identify the cutterhead inside. Watch for TWO sharp blades on the cutterhead.
- Without touching the blades, carefully turn the cutterhead until it stops by the self-engaging latch.
- Use T Wrench to remove 6 bolts on the blade assembly.
- Attach 2 provided magnets to the gib and carefully remove it.
- Attach 2 provided magnets to the blades and carefully remove it.
- Check to see if the blade is dull, worn, nicked, torn, and uneven. These can result in poor performance such as fuzzy grain, chipped grain, raised grain, raised edge, and uneven cut.
- Replace with new blades in pairs only. Never mix new blade with old blade on the cutterhead. Never mix blades with different degrees of wear. Never use a blade where unbalanced wear from side to side is present.
- To replace with the new blade, use the 2 provided magnets to transfer the blade onto the cutterhead. Position the blade so it sits securely on the two pins.
- Use the 2 provided magnets to transfer the gib onto the blade. Position the gib so the 6 holes are aligned with the holes on the cutterhead.
- Tighten and secure with 6 bolts.
- To access the other blade assembly, gently pull and hold the latch on the side of cutterhead to release it. Once the cutterhead rotates, release the latch.
- Without touching the blades, carefully turn the cutterhead until it stops the self-engaging latch.
- Repeat the same procedure to check and replace the other blade.
- Replace the blade cover and secure with the two thumb screws.

Figure 9

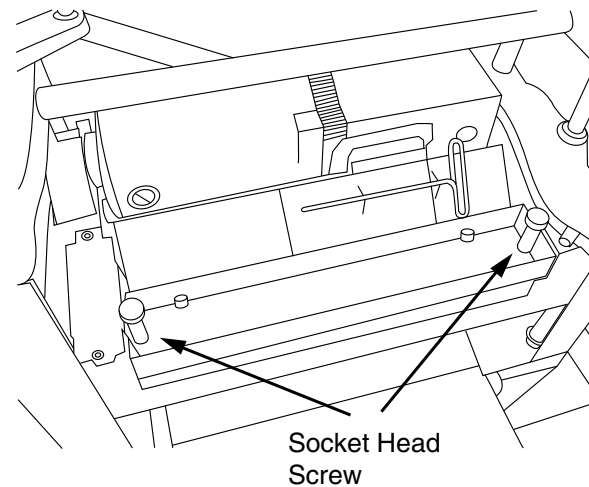
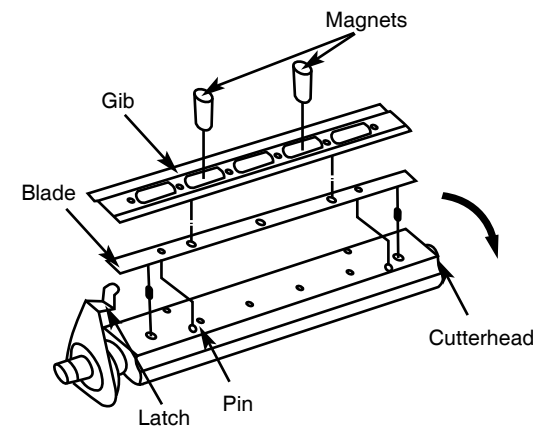

Figure 10

**INSPECT AND REPLACE THE MOTOR BRUSHES**

- Turn the switch to the "OFF" position and disconnect the planer machine from the power source.
- Inspect the motor brushes after every 100 hours of use. Brush life varies, depending on the motor loads.
- Replace the motor brushes in set (two brushes) only. Replace with new parts only.
- To inspect motor brushes, unscrew brush caps on the sides of motor. There are two caps, one on each side of motor.
- Remove brush assembly from motor.
- Replace motor brushes if the length of carbon has been worn to less than 3/8", or if the springs are worn, or if the motor does not run smoothly.
- Replace with new motor brush assembly.
- Replace the brush cap and tighten the screw.
- Repeat the same procedure on the other side of motor.

ADJUST ROLLERCASE LEVEL

Refer to Parts Illustration

The rollercase level is checked in factory and should work properly. However, it can become out of alignment during shipping and handling.

- If the rollercase is not level with the base, the depth-of-cut will not be even from side to side. The end result is tapered cut where the thickness on one side is different from the other side. This can result from uneven wear of the blade as well. Check to see blades are in good working order.
- Test run with two test pieces on right and left ends of the planer to determine the amount needs to be corrected.
- Turn planer off and disconnect from power source. Carefully place the planer on its back.
- Clamp vise plier (not provided) on the left side of shaft (fix spacing) next to the gear.
- Remove retaining ring and disengage right gear from the top gear.
- Slowly rotate handle to raise or lower rollercase. Rollercase will move by 0.006" with every turn of the gear by one tooth. Move rollercase to the required distance to offset the taper.
- Re-engage and remove vise plier.
- Sit the planer upright carefully.
- Test run the planer to check the rollercase level adjustment.
- Repeat the procedures if further adjustment is necessary.

REPLACE V-BELT

Refer to Parts Illustration

Inadequate tension in the V-belt will cause the belt to slip from the motor pulley or drive pulley. A loose belt from must be replaced.

- Turn planer off and unplug from power source.
- Loosen and remove screws on right cap. Remove panel.
- Remove old belt by walking the belt from motor and drive pulleys alternatively. Gently pull the belt outward while turning the pulleys at the same time.
- Replace with new belt. Walk the belt on the pulleys in the reverse manner as when removing the belt.
- Make sure belt is evenly seated all the way on the motor and drive pulley grooves.
- Replace and secure right panel.

CLEAN AND LUBRICATION

- Vacuum the planer machine to remove wood chips, saw dust, and debris.
- Use a cleaning solution (not included) to remove resin and grease residue.
- Check and empty dust collection bag.
- Remove saw dust, wood chips, and grease from chains and gears.
- The bearings in motor and cutterhead units are permanently sealed in factory and should require no further lubrication.
- Three components require regular lubrication: rollercase elevation screws (2x), the columns (4x), and the feed roller chain drive. Remove the top and both side panels to access these components.
- Remove old grease residues, with minerals spirits if necessary, then apply a coat of light grade multi-purpose grease (not included.)
- Chain drive should be cleaned before lubrication. Use spray oil (not included) to lubricate the chain. The chain should be wiped dry after the lubricant has had enough time to penetrate the links.
- The work table and extension table can be coated with very thin lubricating wax (not included) to protect the surface from rust and to facilitate smooth feed during operation.

SYMPTON	POSSIBLE CAUSE(S)	SOLUTIONS
Motor will not start	<ol style="list-style-type: none"> 1. Low voltage 2. Short circuit in line cord or plug 3. Short circuit in motor 4. Open circuit or loose connection in motor 5. Incorrect fuses or circuit breakers 6. Defective switch 7. Motor overload results in circuit breaker tripped 	<ol style="list-style-type: none"> 1. Check power supply for proper voltage 2. Inspect line cord and plug for faulty insulation or shorted connection 3. Inspect connection on motor 4. Inspect connection on motor 5. Replace with correct fuses or circuit breakers 6. Replace switch 7. Turn the machine off and reset overload protection.
Motor stalls or fails to reach full speed	<ol style="list-style-type: none"> 1. Power overload 2. Low voltage from power supply 3. Undersized line cord 4. Motor overload 5. Short circuit or loose connection in motor 6. Incorrect fuses or circuit breakers 7. Wood chips clogged 	<ol style="list-style-type: none"> 1. Reduce workload on the power supply 2. Check power supply for proper voltage 3. Use line cord of adequate size or reduce length of wiring 4. Reduce load on motor 5. Inspect the connection in motor for loose or shorted connection 6. Replace with correct fuses or circuit breakers 7. Inspect chip blower assembly and fan belt. Remove excessive wood chips
Motor overheats	<ol style="list-style-type: none"> 1. Motor overloaded 2. Excessive dust build-up results in decreased air circulation 	<ol style="list-style-type: none"> 1. Reduce load on motor. Turn off the machine until motor cools down 2. Remove dust build-up
Frequent tripping of circuit breaker	<ol style="list-style-type: none"> 1. Motor overload 2. Inadequate capacity of circuit breaker 3. Circuit overload 4. Blades are dull 	<ol style="list-style-type: none"> 1. Reduce load on motor 2. Replace with correct circuit breaker 3. Reduce circuit load 4. Sharpen or replace blades
Snipe	<ol style="list-style-type: none"> 1. Inadequate support of workpiece 2. Blades are dull 3. Uneven force on cutterhead 4. Roller case is not level with planer base 5. Workpiece is not butted properly 	<ol style="list-style-type: none"> 1. Support long workpiece with additional platform 2. Replace blades 3. Push workpiece gently during operation 4. Adjust table and roller case level properly 5. Butt end to end each workpiece as it passes through planer
Surface not smooth	<ol style="list-style-type: none"> 1. Blades are dull 2. Fuzzy grain due to high moisture content in wood 3. Torn grain due to blades cutting against grain 4. The cut is too deep 	<ol style="list-style-type: none"> 1. Replace blades 2. Use dry wood 3. Change direction and feed workpiece along grain 4. Decrease depth of cut
Uneven thickness from side to side	Roller case is not positioned level with planer base	Adjust table and roller case level properly

SYMPTON	POSSIBLE CAUSE(S)	SOLUTIONS
Difficulties in adjusting roller case elevation	<ol style="list-style-type: none"> 1. Worn elevation screws 2. Dirty elevation screws or columns 3. Dirty chains or sprockets 4. Roller case is not positioned level with planer base 5. Friction between roller case and covers 	<ol style="list-style-type: none"> 1. Release roller case lock 2. Replace elevation screws 3. Clean and lubricate elevation screws and columns 4. Clean and lubricate chains and sprockets 5. Adjust table and roller case level properly 6. Clean and adjust roller case
Wood thickness does not match depth of cut setting	Indicator is not set correctly	Adjust and tighten indicator properly
Chain jumping	<ol style="list-style-type: none"> 1. Worn chains 2. Worn Sprockets 	<ol style="list-style-type: none"> 1. Replace chains 2. Replace sprockets
Belt slipping	Belt is loose	Replace V-belt
Excessive fan noise	<ol style="list-style-type: none"> 1. Loose fan assembly 2. Large wood chips stuck in fan housing 	<ol style="list-style-type: none"> 1. Inspect fan assembly and tighten fan screws 2. Turn machine off, remove blade guard, and clean the chamber

Figure 11

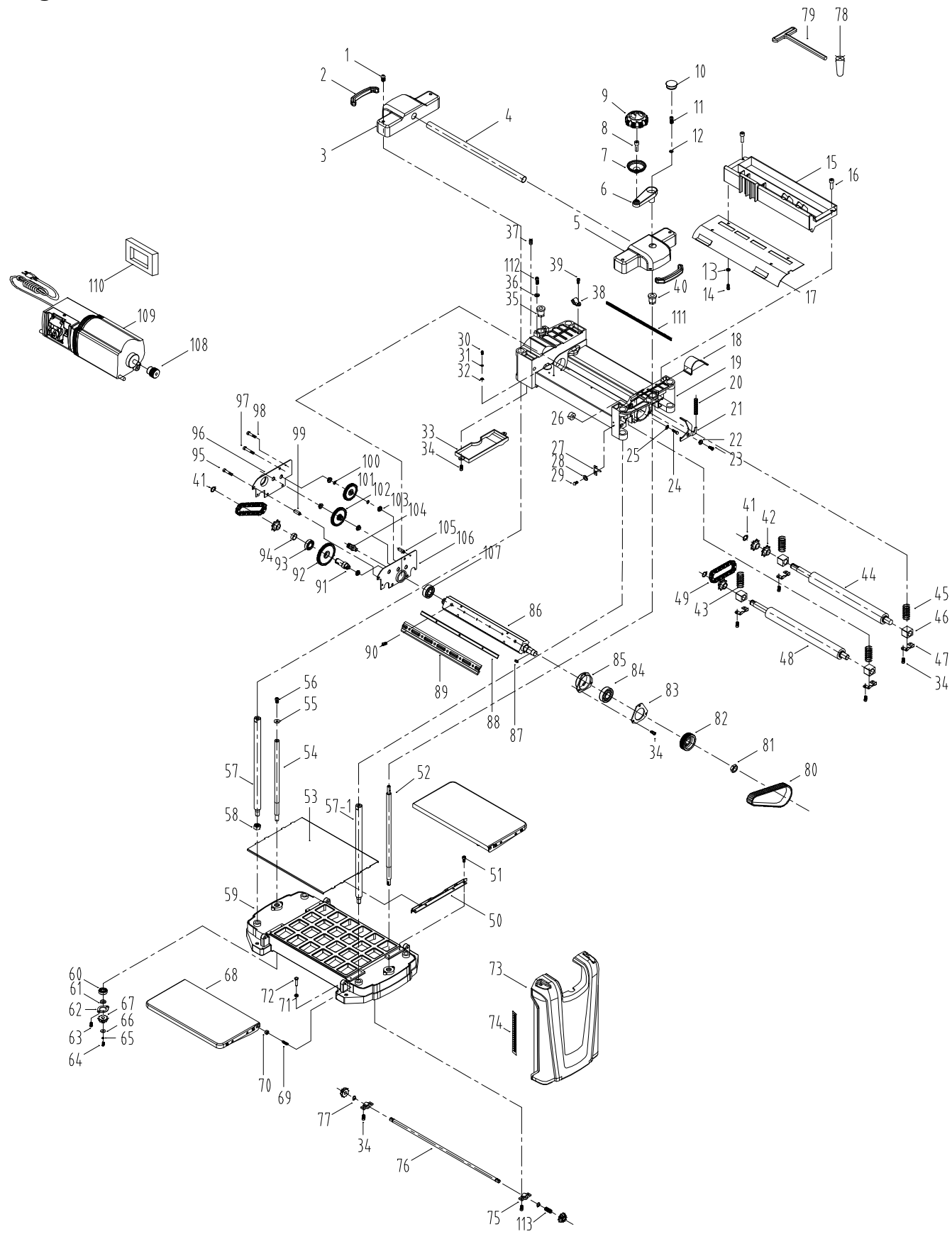

Key No.	Part No.	Description	Specification	Qty	Key No.	Part No.	Description	Specification	Qty
1	PL1250001	PAN HEAD SCREW	M8*16	4	59	PL1251035	BASE		1
2	PL1250002	PORTABLE SHEATH		2	60	PL1250102	BEARING	6000ZZ	2
3	PL1250003	LEFT CAP		1	61	PL1250105	SPACER		2
4	PL1250004	ROLLER	20x2.0Tx392L	1	62	PL1250103	RETAINER		2
5	PL1250005	RIGHT CAP		1	63	PL1251036	PAN HEAD SCREW	M5 x 12	4
6	PL1250004.6	CRANK ARM		1	64	PL1250109	SOCKET HEAD SCREW	M4 x 12	2
7	PL1250004.5	HANDLE		1	65	PL1250108	SPRING WASHER	Ø4	2
8	PL1250004.4	HANDLE SHAFT		1	66	PL1250107	FLAT WASHER	Ø4	2
9	PL1250004.3	HANDLE CAP		1	67	PL1250106	GEAR		4
10	PL1250004.1	PLUG		1	68	PL1251037	EXTEND TABLE ASSEMBLY		2
11	PL1250006	SOCKET HEAD SCREW	M5*20	1	69	PL1251038	ADJUST SCREW		4
12	PL1250007	WASHER	Ø5	1	70	PL1251039	HEX NUT	M10	4
13	PL1250008	WASHER	Ø5	4	71	PL1250099	HEX NUT	M6	4
14	PL1250012	TAPPING SCREW	ST4.8x10L	4	72	PL1250098	HEX BOLT	M6 x 20	4
15	PL1251009	DUST HOOD		1	73	PL1251040	SIDE COVER		2
16	PL1251010	SOCKET HEAD SCREW	M6 x 14	2	74	PL1250122	SCALE	22 x 181	1
17	PL1251012	DUST CHUTE		1	75	PL1250117	SUPPORT		2
18	PL1251013	BELT GUARD		1	76	PL1251041	SHAFT		1
19	PL1250046	CARRIAGE FRAME		1	77	PL1250120	EXTEND RET RING	Ø10	2
20	PL1250064	SPRING		1	78	PL1250125	MAGNET		1
21	PL1250065	CUTTERHEAD LOCK PLATE		1	79	PL1250126	HEX WRENCH	M4x130x70	1
22	PL1250066	SPACER		1	80	PL1250062	BELT	135J6	1
23	PL1250067	SOCKET HEAD SCREW	M5 x 16	1	81	PL1251042	HEX NUT		1
24	PL1251014	HEX BOLT	M8 x 20	1	82	PL1250061	PULLEY		1
25	PL1251015	FLAT WASHER	Ø8	1	83	PL1251043	BEARING COVER		1
26	PL1251016	SPACER		1	84	PL1251044	BEARING	6204	1
27	PL1251017	POINTER		1	85	PL1251045	BEARING SEAT		1
28	PL1251018	FLAT WASHER	Ø3	2	86	PL1251046	CUTTERHEAD		1
29	PL1251019	CROSS HEAD SCREW	M3 x 6	2	87	PL1250056	KEY	A5 x 12	1
30	PL1251020	CROSS HEAD SCREW	M5 x 8	2	88	PL1250053	BLADE		2
31	PL1251021	SPRING WASHER	Ø5	2	89	PL1250052	GIB		2
32	PL1250048	SERRATED WASHER	Ø5.3xØ10	2	90	PL1250057	PAN HEAD SCREW	M6*16(12.9)	12
33	PL1251022	GEARBOX COVER		1	91	PL1250026	SHAFT		1
34	PL1251023	SOCKET HEAD SCREW	M5 x 12	16	92	PL1250027	GEAR	70T	1
35	PL1250088	ELEVATING NUT (L.H.)		1	93	PL1250025	BEARING	6002-2Z	1
36	PL1250090	FLAT WASHER	Ø6.3 x 15 x 2T	4	94	PL1250022	SPACER		1
37	PL1250040	SET SCREW	M5 x 10	1	95	PL1250023	SOCKET HEAD SCREW	M5 x 30	1
38	PL1250039	CORD CLAMP	UC-1.5	1	96	PL1251047	OUTSIDE COVER		1
39	PL1250038	CROSS HEAD SCREW	M5 x 10	1	97	PL1250019	SOCKET HEAD SCREW	M5 x 35	3
40	PL1250091	ELEVATING NUT (R.H.)		1	98	PL1251048	SOCKET HEAD SCREW	M5 x 27	2
41	PL1250080	EXTEND RET RING	Ø15.7	3	99	PL1250031	SPACER B		4
42	PL1250021	SPROCKET		4	100	PL1250029	GEAR	52T+12T	1
43	PL1251024	SPRING (INFEED)		2	101	PL1251049	WASHER	Ø8 x Ø14 x 0.1	2
44	PL1251025	OUTFEED ROLLER		1	102	PL1250028	GEAR	58T+12T	2
45	PL1251026	SPRING (OUTFEED)		2	103	PL1250030	BUSHING		1
46	PL1251027	BEARING BLOCK		4	104	PL1250032	PINION		5
47	PL1251028	RETAINER		4	105	PL1250034	SPACER A		1
48	PL1251029	INFEED ROLLER		1	106	PL1251050	INSIDE COVER		1
49	PL1250081	CHAIN	#410-26	2	107	PL1250033	BEARING	6203-2Z	1
50	PL1251030	GUIDE		2	108	PL1251051	MOTOR PULLEY		1
51	PL1251031	SOCKET HEAD SCREW	M5 x 10	8	109	PL1251052	MOTOR		1
52	PL1251032	ELEVATING SCREW (R.H.)		1	110	PL125068.2	SPONGE	140 x 60 x 90	1
53	PL1251033	PLATEN		1	111	PL1250016	SPONGE	320 x 10 x 8	3.5
54	PL1250093	ELEVATING SCREW (L.H.)		1	112	PL1250089	SOCKET HEAD SCREW	M6 x P1 x 16L	4
55	PL1251034	FLAT WASHER	Ø6	1	113	PL1251053	SPRING		1
56	PL1250086	SOCKET HEAD SCREW	M6 x 10	1					
57	PL1250092	COLUMN		3					
57-1	PL1250092-1	VICE COLUMN		1					
58	PL1250100	HEX NUT	M12	4					

Thank you for investing in a **POWERTEC** power tool. These products have been made to demanding, high-quality standards and are guaranteed for domestic use against manufacturing faults for a period of 12 months from the date of purchase.

This guarantee does not affect your statutory rights. In case of any malfunction of your tool (failure, missing part, etc.), please contact one of our service technician at our service line at **1-877-393-7121** from 9 AM to 5 PM, Monday to Friday, Central time. **Southern Technologies, LLC** reserves the right to repair or replace the defective tool, at its discretion.

Normal wear and tear, including accessory wear, is not covered under guarantee. The product is guaranteed for 12 months if used for normal trade purposes. Any guarantee is invalid if the product has been overloaded or subject to neglect, improper use or an attempted repair other than by an authorized agent. Heavy-duty, daily professional or hire usage are not guaranteed. Due to continuous product improvement, we reserve the right to change the product specification without prior notice.

SOUTHERN TECHNOLOGIES LLC. BENCH TOP AND STATIONARY POWER TOOL LIMITED 1 YEAR WARRANTY AND 30-DAY SATISFACTION GUARANTEE POLICY

This product is manufactured by **Southern Technologies LLC.** under a trademark license from **Southern Technologies LLC.** All warranty communications should be directed to **Southern Technologies LLC.** 206 Terrace Dr. Mundelein, IL 60060, Attn: **Southern Technologies Service Bench Top and Stationary Power Tool** technical service at (toll free) 1-877-393-7121.

30- DAY SATISFACTION GUARANTEE POLICY

During the first 30 days after the date of purchase, if you are dissatisfied with the performance of this **Southern Technologies** tool for any reason you may return the tool to the Retailer from which it was purchased for a full refund or exchange. To receive a replacement tool you must present proof of purchase and return all original equipment packaged with the original product. The replacement tool will be covered by the limited warranty for the balance of the one year warranty period.

WHAT IS COVERED UNDER THE LIMITED ONE YEAR WARRANTY

This warranty covers all defects in workmanship or materials in this **Southern Technologies** tool for a one year period from the date of purchase. This warranty is specific to this tool.

HOW TO OBTAIN SERVICE

To obtain service for this **Southern Technologies** tool you must return it, freight prepaid, to an authorized **Southern Technologies** service center for bench top and stationary power tools. You may obtain the location of the authorized service center nearest you by calling (toll free) 1-877-393-7121 or by logging on to the **Southern Technologies** website at www.southerntechllc.com. When requesting warranty service, you must present the proof of purchase documentation, which includes a date of purchase. The authorized service center will repair any faulty workmanship, and either repair or replace any defective part, at our option at no charge to you.

WHAT IS NOT COVERED

This warranty applies only to the original purchaser at retail and may not be transferred. This warranty only covers defects arising under normal usage and does not cover any malfunction, failure or defect resulting from misuse, abuse, neglect, alteration, modification or repair by other than an authorized service center for **Southern Technologies** bench top and stationary power tools. Warranty excludes: Consumable Items i.e. Saw Blades, Knives, Belts and Disc, Cooling blocks etc.

SOUTHERN TECHNOLOGIES LLC., MAKES NO WARRANTIES, REPRESENTATIONS OR PROMISES AS TO THE QUALITY OR PERFORMANCE OF ITS POWER TOOLS OTHER THAN THOSE SPECIFICALLY STATED IN THIS WARRANTY.

ADDITIONAL LIMITATIONS

To the extent permitted by applicable law, all implied warranties, including warranties of MERCHANTABILITY or FITNESS FOR A PARTICULAR PURPOSE, are disclaimed. Any implied warranties, including warranties of merchantability or fitness for a particular purpose, that cannot be disclaimed under state law are limited to one year from the date of purchase. **Southern Technologies LLC.** is not responsible for direct, indirect, incidental or consequential damages. Some states do not allow limitations on how long an implied warranty lasts and/or do not allow the exclusion or limitation of incidental or consequential damages, so the above limitations may not apply to you. This warranty gives you specific legal rights, and you may also have other rights which vary from state to state.

NOTE

POWERTEC[®]

Southern Technologies, LLC
206 Terrace Drive
Mundelein, Illinois 60060