

First Alert[®]

INDOOR WEATHER STATION WITH PROJECTION CLOCK



USER MANUAL SFA2200

**PLEASE READ THIS USER MANUAL COMPLETELY BEFORE
OPERATING THIS UNIT AND RETAIN IT FOR FUTURE REFERENCE**

IMPORTANT SAFETY INSTRUCTIONS

When used in the directed manner, this unit has been designed and manufactured to ensure your personal safety. However, improper use can result in potential electrical shock or fire hazards. Please read all safety and operating instructions carefully before installation and use, and keep these instructions handy for future reference. Take special note of all warnings listed in these instructions and on the unit.

1. Read these instructions – All the safety and operating instructions should be read before the appliance is operated.
2. Keep these instructions – The safety and operating instructions should be kept for future reference.
3. Heed all warnings – All warnings on the appliance and in the operating instructions should be adhered to.
4. Follow all instructions – All operation and use instructions should be followed.
5. Do not use this apparatus near water – The appliance should not be used near water; for example, near a bath tub, washbowl, kitchen sink, laundry tub, in a wet basement, or near a swimming pool.
6. Clean only with dry cloth – The appliance should be cleaned only as recommended by the manufacturer.
7. Do not install near any heat sources such as radiators, heat registers, stoves, or other apparatus (including amplifiers) that produce heat.
8. Only use attachments / accessories specified by the manufacturer.
9. Refer all servicing to qualified service personnel. Servicing is required when the apparatus has been damaged in any way, such as power-supply cord or plug is damaged, liquid has been spilled or objects have fallen into the apparatus, the apparatus has been exposed to rain or moisture, does not operate normally, or has been dropped.
10. This appliance shall not be exposed to dripping or splashing water and that no object filled with liquids such as vases shall be placed on the apparatus.
11. Power Sources – The appliance should be connected to a power supply only of the type described in the operating instructions or as marked on the appliance. Do not overload wall outlet.
12. Danger of explosion if battery is incorrectly replaced. Replace only with the same or equivalent type.
13. Do not attempt to dismantle, open or repair this product yourself. If a fault occurs, seek advice from your local qualified service technician or contact the distributor via the telephone number at the back of this instruction manual.
14. Caution marking and nameplate are located on back of product.

COMPLIANCE WITH FCC REGULATIONS

This device complies with Part 15 of the FCC Rules. Operation is subject to the following two conditions:

- (1) this device may not cause harmful interference, and
- (2) this device must accept any interference received, including interference that may cause undesired operation.

NOTE: This equipment has been tested and found to comply with the limits for a Class B digital device, pursuant to Part 15 of the FCC Rules. These limits are designed to provide reasonable protection against harmful interference in a residential installation. This equipment generates, uses and can radiate radio frequency energy and, if not installed and used in accordance with the instructions, may cause harmful interference to radio communications. However, there is no guarantee that interference will not occur in a particular installation. If this equipment does cause harmful interference to radio or television reception, which can be determined by turning the equipment off and on, the user is encouraged to try to correct the interference by one or more of the following measures:

- Reorient or relocate the receiving antenna.
- Increase the separation between the equipment and receiver.
- Connect the equipment into an outlet on a circuit different from that to which the receiver is connected.
- Consult the dealer or an experienced radio/TV technician for help.

CAUTION: Changes or modifications not expressly approved by the party responsible for compliance could void the user's authority to operate the equipment.

SPECIAL NOTE

This model is equipped with non-skid rubber 'feet' to prevent the product from moving when you operate the controls. These 'feet' are made from non-migrating rubber material specially formulated to avoid leaving any marks or stains on your furniture. However certain types of oil based furniture polishes, wood preservatives, or cleaning sprays may cause the rubber 'feet' to soften, and leave marks or a rubber residue on the furniture. To prevent any damage to your furniture we strongly recommend that you purchase small self-adhesive felt pads, available at hardware stores and home improvement centers everywhere, and apply these pads to the bottom of the rubber 'feet' before you place the product on fine wooden furniture.

LOCATION OF CONTROLS

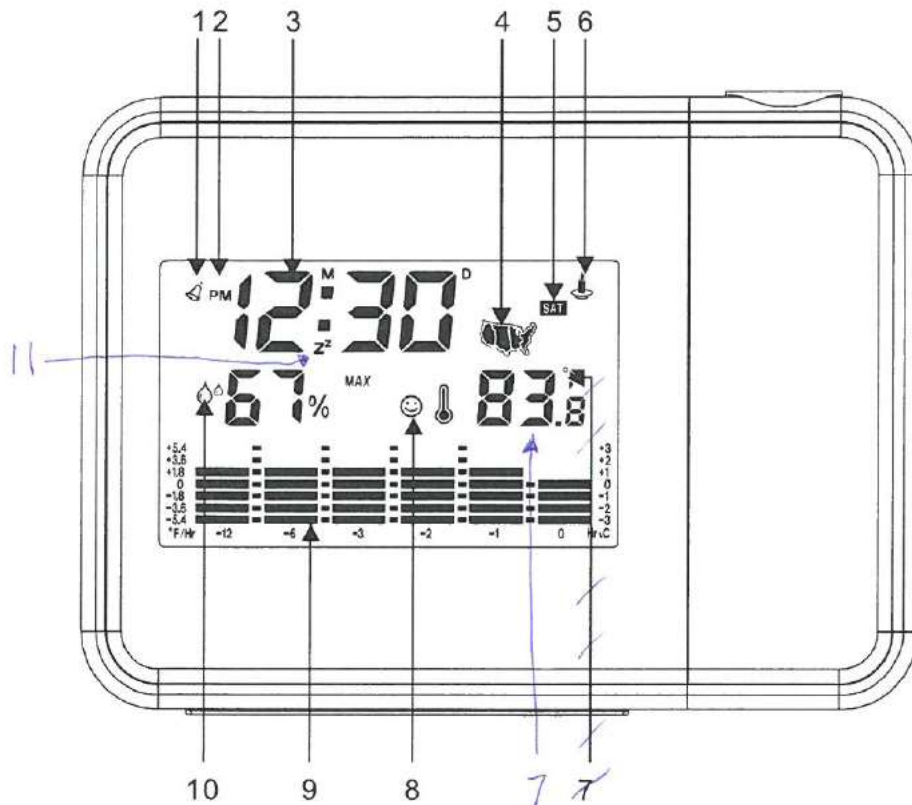

1. Alarm ON/OFF Indicator
2. PM Time Indicator
3. Multi-Function Display
4. Time Zone Map
5. Day of the Week Indicator
6. Special Day Reminder
7. Temperature Reading
8. Comfort Level Indicator
9. Past 12 hour Temperature Trend Indicator
10. Humidity Reading
11. Snooze Indicator

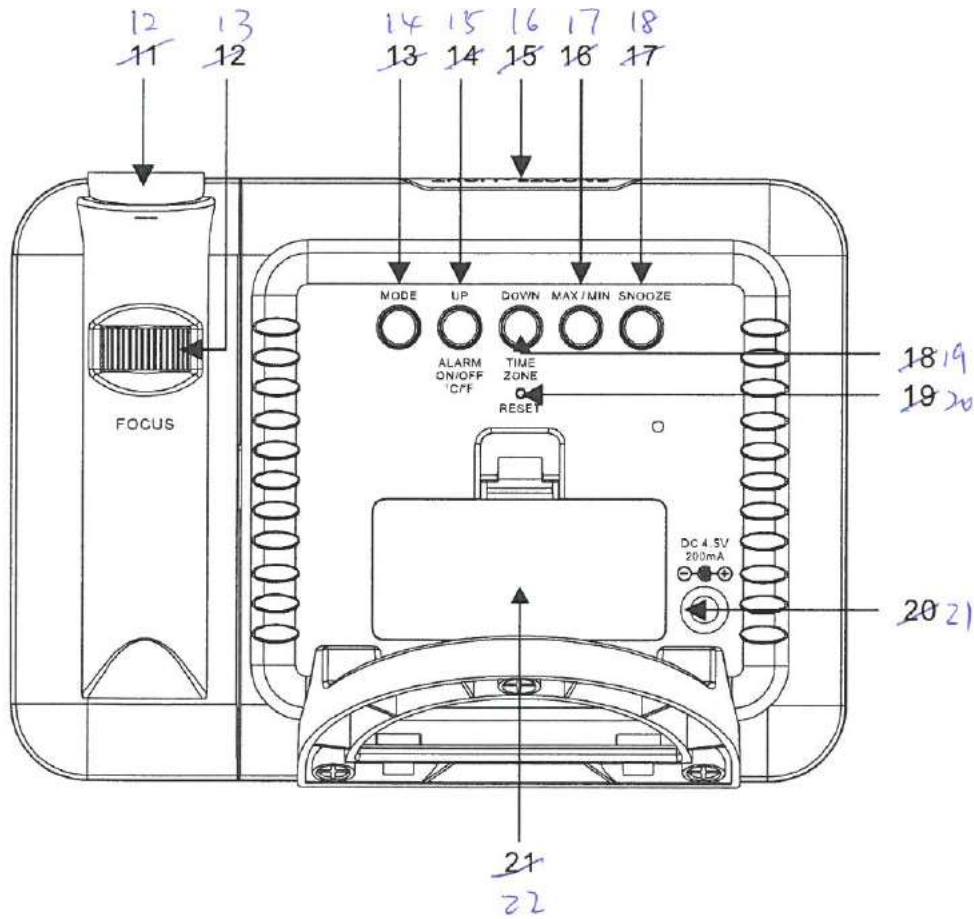

- 12. Projector
- 13. Projector Focus Adjust Knob
- 14. MODE Button
- 15. Adjust UP; ALARM ON/OFF; °C /°F Button
- 16. SNOOZE/LIGHT Button
- 17. Maximum/Minimum Temperature Button
- 18. SNOOZE Button
- 19. Adjust DOWN/Time Zone button
- 20. RESET Button
- 21. DC-IN Jack
- 22. Battery Door

POWER SOURCE

This unit operates using the included AC-DC Adaptor or on 2 X AAA batteries (not included)

AC POWER OPERATION

An AC-DC Adaptor with the output 4.5V DC 200mA (included) is required for operating the main unit in AC power mode.

- 1.) To connect the AC-DC Adaptor to the unit, firmly and securely insert the DC plug of the adaptor into the DC Jack located on the left hand side of the back of the unit.
- 2.) Plug the AC-DC Adaptor plug into a household AC outlet that supplies 120V AC ~ 60Hz.

Connecting this system to any other power source may cause damage to the system.

NOTE: When the AC-DC adaptor is connected to the DC Jack, the batteries are automatically disconnected.

BATTERY OPERATION

1. Open the Battery Door on the back of the main unit.
2. Following the polarity (+ and -) diagrams shown inside the battery compartment, insert 2 'AAA' (UM-4) batteries (not included).

Note: For optimum performance, alkaline-type batteries are recommended.

3. Replace the Battery Door.

IMPORTANT: Be sure that the batteries are installed correctly. Wrong polarity may damage the unit.

BATTERY NOTE AND CARE

- Danger of explosion if the battery is replaced incorrectly. Replace only with the same or equivalent type.
- Do not mix old and new batteries.
- Do not mix alkaline, standard (carbon-zinc) or rechargeable (nickel-cadmium) batteries.
- If the unit is not to be used for an extended period of time, remove the battery. Any old or leaking battery can cause damage to the unit and may void the warranty.
- Do not dispose of batteries in fire, batteries may explode or leak.
- Do not try to recharge batteries not intended to be recharged; they can overheat, rupture and leak(Follow battery manufacturer's directions).
- Only an adult should replace the batteries

CLOCK SETTING

When the unit is in clock display mode:

Setting the Time Zone

The unit default is Pacific time (P). Tap the TIME ZONE button on the back repeatedly to select another time zone if necessary. The time zone will change in the following order when you press the TIME ZONE button.

Pacific Time (P) → Mountain Time (M) → Central Time (C) → Eastern Time (E)



12/24 Hour format

1. The unit default is 12 hour format. Press and hold the MODE button for 3 seconds; 12 hour format (H 12) will appear on display and flash.
2. Tap the UP/DOWN button to change clock setting display to 24 hour format (H 24) if necessary.

Setting the Clock

3. Tap the MODE button to confirm, the hour digits will flash to prompt for input.
4. Tap the Adjust UP/DOWN button repeatedly to set the hour.

Note: Make sure the hour is set so that the **PM** indicator is displayed correctly.

5. Tap the MODE button after the hour is set, the Minute digits flash to prompting for input.
6. Tap the Adjust UP/DOWN button repeatedly to set the minute value. Press and hold the buttons to speed up the forward or reverse scanning of the digits.
7. Tap the MODE button again to finish clock setting.

Note: If the unit was reset, you need to set the clock again.

CALENDAR SETTING

When the unit is in clock display mode:

1. Tap the MODE button once to enter the calendar setting mode. Month and Date digit shows on display.
2. When the Month and Date show on the display, press and hold the MODE button for 3 seconds, the Year digits will flash to prompt for input.
3. Tap the Adjust UP/DOWN button repeatedly to set the year.
4. Tap the MODE button after the year is set, the Month digits flash to prompt for input.
5. Tap the Adjust UP/DOWN button repeatedly to set the month.
6. Tap the MODE button after the month is set, the Date digits flash to prompt for input.
7. Tap the Adjust UP/DOWN button repeatedly to set the date. Press and hold the buttons to speed up the forward or reverse scanning of the digits.
8. Tap the MODE button to finish the setting. Tap the MODE button 3 times or wait for few seconds to exit calendar setting mode.



ALARM SETTING

Setting the Alarm Time

1. In clock display mode, tap the MODE button twice to enter the Alarm setting mode, the alarm indicator  and time 12:00 appear on the display.
2. Press and hold the MODE button for 3 seconds, the Hour digits will flash.
3. Tap the Adjust UP/DOWN button repeatedly to set the hour value. Press and hold the buttons to speed up the forward or reverse scanning of the digits.
Note: Make sure the hour is set so that the **PM** indicator is displayed correctly.
4. Tap the MODE button after the hour is set, the Minute digits flash to prompt for input.
5. Tap the Adjust UP/DOWN button repeatedly to set the minute value. Press and hold the button to speed up the forward or reverse scanning of the digits.
6. Tap the MODE button after minute is set, Alarm melody type "00" flashing to prompt for input. There are total 13 kinds of alarm melody (00-12) available for selection.
7. Tap the Adjust UP/DOWN button repeatedly to select the alarm melody you desired.
8. Tap the MODE button to finish the setting. Tap the MODE button twice again or wait for few seconds to exit alarm setting mode.
9. Alarm will sound for 2 minutes when set time comes. Tap the MODE button once to turn off the alarm until next day.

Turning the Alarm ON/OFF





In clock display mode,

- Tap the ALARM ON/OFF button repeatedly in alarm OFF mode until the alarm icon  appears on display to turn on the alarm.
- Tap the ALARM ON/OFF button repeatedly in alarm ON mode until the alarm icon  disappear from display to turn off the alarm

SNOOZE

- When the alarm sounds, it can be temporarily stopped by pressing the SNOOZE/LIGHT button on top panel or SNOOZE button on back. Snooze indicator **z^z** appears in display and flashing with Alarm indicator  together.
- The alarm will be delayed for 8 minutes and then come again.
- This manual snooze operation can be repeated again and again while alarm sounding.

SPECIAL DAY REMINDER SETTING

1. In clock display mode, tap the MODE button three times to enter the special day reminder setting mode. The Month and Date of reminder indicator  will appear in display.
Note: Make sure you are in special day setting mode, and not in calendar mode.
2. Press and hold the MODE button for 3 seconds, the reminder month digit flashes. Tap the Adjust UP/ DOWN button repeatedly to set your reminder month.
3. Tap the MODE button to confirm, the date digit flash. Tap the Adjust UP/ DOWN button repeatedly to set your reminder date.
4. Tap the MODE button to confirm, the hour digits flash. Tap the Adjust UP/ DOWN button repeatedly to set the hour.
Note: Make sure the hour is set so that the **PM** indicator is displayed correctly.
5. Tap the MODE button to confirm, the minute digits flash. Tap the Adjust UP/ DOWN button repeatedly to set the minute.
6. Tap the MODE button to finish the setting. Special Day reminder indicator  will show on the display.
7. The Special Day melody will play for 2 minutes when set date comes if not interrupted, the reminder indicator  will be flashing on the display.
8. Press any button to stop the melody immediately. It will sound again next year on the same day set.
Note: The Snooze has no effect on the special day reminder.
9. To cancel the special day reminder, tap the ALARM ON/OFF repeatedly until the special day reminder indicator  goes off on the display.

INDOOR TEMPERATURE OPERATION

INDOOR WEATHER MEASUREMENT

- NOTE:** 1.) The main unit display backlight will remain lit when using the AC power adaptor.
- 2.) When using battery power, the backlight will turn off automatically to save battery power. Press the LIGHT/SNOOZE button once, and the backlight will turn on for 7 seconds. Pressing other buttons on the front panel will not turn on the backlight.

Viewing the Time Zone

In clock display mode, tap the TIME ZONE button repeatedly to view the time in different time zones.

Changing the Temperature Display format

In clock display mode, press and hold the °C /°F button on back panel of the main unit to change the temperature display degrees format from Celsius (°C) to Fahrenheit (°F) mode.

Indoor Weather Measurement

The indoor temperature and humidity is displayed in the Temperature Window on the main unit display.

Checking & Deleting the Max/Min Temperature Record

1. Tap the MAX/MIN button on back panel once to check the maximum temperature and humidity record. Tap it twice to check the minimum record. Tap it again to exit.
2. Maximum and minimum temperature and humidity records will be deleted automatically at 12:00 AM everyday.

Comfortable level Indicators

The three comfortable weather icons below represent the current comfort levels (Dry, Comfort and Wet) of the room the SFA2200 is placed in.

1. No matter what the temperature is, when the humidity is under 40%, the display will show the DRY icon.
2. When temperature is between 68°F (20°C) and 77°F (25°C), and when humidity is between 40% and 70%, the display will show the COMFORT icon.
3. No matter what the temperature is, when the humidity is higher than 70%, the display will show the WET icon.



DRY



COMFORT



WET

NOTE: 1.) When temperature is between 68°F (20°C) and 77°F (25°C), and the humidity is between 40% and 70%, no icon will be displayed.

Temperature Trend of past 12 hours

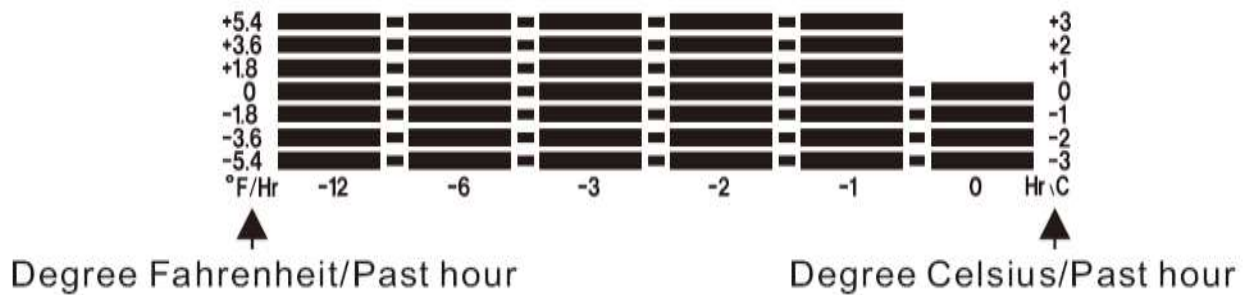

Dynamic BAR graph trend of indoor temperature for the past 12 hours

This unit is equipped with a dynamic temperature trend feature for the past 12 hours. It moves from right to left to indicate the temperature changes by comparing the past hour temperature to the current temperature. Maximum range is up to +/- 5.8 °F (+/- 3 °C) at past 1, 2, 3, 6 and 12 hours.

How to read temperature trend

1. Horizontal scale of 0, -1, -2, -3, -6 & -12 mean current time (0), past 1, 2, 3, 6 & 12 hour respectively.
2. Vertical Scale of +/- 5.8, 3.6, 1.8, 0 degree (+/- 3, 2, 1, 0 degree °C) mean temperature changes compared to current temperature.
3. The unit will detect temperature trends automatically and needs at least one hour before it can start displaying the temperature changes. It's recommended to begin reading the trend after the unit is on and working for 12 hours or longer.
4. As time passes, the display will show the temperature rising or falling trend by turning the bars ON/OFF automatically based on past 12 hour temperature readings.

- Note:**
- 1.) One lighting bar scale = 1.8 °F (1°C).
 - 2.) If the temperature change exceeds +/-3°C, a full BAR graph or 1 BAR graph will be displayed.
 - 3.) The temperature trend is calculated by changes in the temperature and is indicative only. The calculation can be affected by many things including where the unit is placed.
 - 4.) The unit is for indoor use only. There are no guarantees for the accuracy when

using this unit for forecasting outdoor weather conditions.

USING THE PROJECTOR

Rotate the projector to project the time onto a dark wall or ceiling within 2.3 – 6.6 feet (0.7 - 2 meters) away from the projector, the projected time will be displayed on the wall or ceiling in the following format.

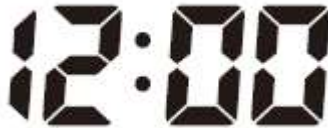

1. The projector stays on when the main unit is powered by the AC adaptor.
2. The projector will be off when the main unit is powered by batteries. Pressing the “SNOOZE/LIGHT” button will momentarily turn on the display back light and the projection for 7 seconds.
3. Rotate the Projector angle to adjust where the time is projected.
4. Adjust the FOCUS control knob of projector to sharpen the projected time.

NOTE: The projector can be rotated $\pm 90^\circ$.

CARE AND MAINTENANCE

1. Do not subject the unit to excessive force, shock, dust or extreme temperature.
2. Do not tamper the internal components of the unit.
3. Clean your unit with a damp (never wet) cloth. Solvent or detergent should never be used.
4. Avoid leaving your unit in direct sunlight or in hot, humid or dusty places.
5. Keep your unit away from heating appliances and sources of electrical noise such as fluorescent lamps or motors.

CAUTION: Never allow any water or other liquids to get inside the unit while cleaning.

Resetting the Unit

If the unit experiences a power surge or electric shock, it is possible that the internal micro-controller may lock up and the unit will not respond to any commands from the back panel controls. In this event, use a straightened paper clip, toothpick or similar objects to press the RESET button located on the back of the unit (see the below figure). The reset operation clears the system memory and all of your previous settings will be erased.

CAUTION: DO NOT USE A SHARP OR POINTED OBJECT TO PRESS THE RESET BUTTON. IT MAY DAMAGE THE RESET SWITCH INSIDE THE UNIT.

©2014 BRK Brands Inc. All rights reserved. First Alert® is a registered trademark of the First Alert Trust.



At Spectra, environmental and social responsibility is a core value of our business. We are dedicated to continuous implementation of responsible initiatives with an aim to conserve and maintain the environment through responsible recycling.

Please visit us at <http://www.spectraintl.com/green.htm> for more information on Spectra's green initiatives or to find a recycler in your area.

**1 YEAR LIMITED WARRANTY AND SERVICE
VALID IN THE U.S.A ONLY**

This product is manufactured, distributed or sold by SPECTRA MERCHANDISING INTERNATIONAL, INC., official licensee for this product. All right, title and interest to use the "First Alert" logo trademarks and the "First Alert" trade dress are exclusively licensed by BRK Brands, Inc. and are used under license from BRK Brands, Inc.. Please contact SPECTRA's Service Department for questions/comments, warranty, support, or service related to this product.

SPECTRA MERCHANDISING INTERNATIONAL, INC. warrants that this product 1) is free from defects in materials and workmanship and 2) conforms to its specifications for a period of 1 year from the date of original customer purchase and provided the product is utilized within the U.S.A. This warranty is not assignable or transferable. Our obligation under this warranty is the repair or replacement of the defective unit or any part thereof, except batteries, when it is returned to the SPECTRA Service Department, accompanied by proof of the date of original consumer purchase, such as a duplicated copy of a sales receipt.

You must pay all shipping charges required to ship the product to SPECTRA for warranty service. If the product is repaired or replaced under warranty, the return charges will be at SPECTRA's expense. There are no other express warranties other than those stated herein.

This warranty is valid only in accordance with the conditions set forth below:

1. The warranty applies to the SPECTRA product only while:
 - a. It remains in the possession of the original purchaser and proof of purchase is demonstrated
 - b. It has not been subjected to accident, misuse, abuse, improper service, usage outside the descriptions and warnings covered within the owner's manual or non-SPECTRA approved modifications
 - c. Claims are made within the warranty period
2. This warranty does not cover damage or equipment failure caused by electrical wiring not in compliance with electrical codes or SPECTRA owner's manual specifications, or failure to

provide reasonable care and necessary maintenance as outlined in the owner's manual.

3. Warranty of all SPECTRA products applies to residential use only and is void when products are used in a nonresidential environment or installed outside the United States.

This warranty gives you specific legal rights, and you may also have other rights which vary from state to state. TO OBTAIN SERVICE please remove all batteries (if any) and pack the unit carefully and send it prepaid by insured parcel post or UPS to SPECTRA at the address shown below. IF THE UNIT IS RETURNED WITHIN THE WARRANTY PERIOD shown above, please include a proof of purchase (dated cash register receipt) so that we may establish your eligibility for warranty service and repair of the unit without cost. Also include a note with a description explaining how the unit is defective. A customer service representative may need to contact you regarding the status of your repair, so include your name, address, phone number and e-mail address to speed the process.

IF THE UNIT IS OUTSIDE THE WARRANTY PERIOD, please include a check for \$8.00 to cover the cost of repair, handling and return postage. All out of warranty returns must be sent prepaid.

It is recommended that you contact SPECTRA first at 1-800-777-5331 or by e-mail at custserv@spectraintl.com for updated information on the unit requiring service. In some cases the model you have may be discontinued and SPECTRA reserves the right to offer alternative options for repair or replacement.

SPECTRA MERCHANDISING INTERNATIONAL, INC.
4230 North Normandy Avenue,
Chicago, IL60634, USA.
1-800-777-5331

To register your product, visit the link below on the website to enter your information.
<http://www.spectraintl.com/wform.htm>

0614

Printed in China