

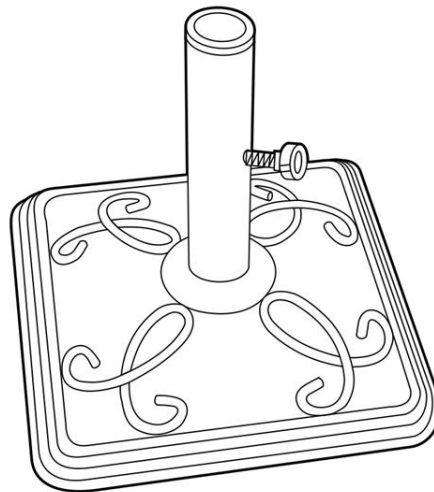

Live life Comfortably.™



USE AND CARE GUIDE

Sears Peyton Umbrella Base

Product Code: D71 M80908

UPC Code: 7 22938 07959 9

Date of Purchase: __ / __ / __

La-Z-Boy® is a registered trademark of La-Z-Boy Incorporated and is used under license to BJI, Inc.

© 2015 La-Z-Boy Incorporated.

Thank you for your purchase

THANK YOU FOR YOUR PURCHASE!

We are pleased that you have chosen Sears for your outdoor furniture purchase. We hope that you enjoy the unmatched quality, comfort, and style of your new patio set. Every piece is meticulously considered all the way down to the smallest details, exclusively for you, by our world class design team, We know you have a choice when it comes to your patio furniture needs, so from our team to yours, thank you for letting us be a part of your outdoors.

Table of Contents

Table of Contents.....	2
Safety Information	3
Warranty	3
What is covered	3
What is not covered	3
Care and Maintenance	4
Pre-Assembly	5
Planning Assembly	5
Hardware Included	5
Package Contents.....	6
Assembly Instruction	7
Customer Service	9

Safety Information

THIS IS NOT A FREE-STANDING UMBRELLA BASE. THIS BASE MUST BE USED UNDER A MATCHING TABLE.



DANGER: Do not allow children to play with plastic wraps or small parts to prevent potential choking hazard.



CAUTION: Read all the instructions before assembly. Failure to do so may result in faulty assembly and potential injury!

NOTICE: As a safety precaution, when umbrella is not in use please crank down and take completely out of the base and store in a safe location.

Warranty

THIS IS A RESIDENTIAL WARRANTY AND DOES NOT APPLY FOR COMMERCIAL USE.

1 YEAR WARRANTY FOR FRAME.

WHAT IS COVERED

We warrant the frame to be free of manufacturing defects to the original purchaser for 1 year.

WHAT IS NOT COVERED

It remains the customer's responsibility for freight and packaging charges to and from our service center.

This warranty does not cover commercial use, hardware, acts of nature, fire, freezing and abusive use.

Discoloration or fading of the finish or fabrics as a result of chemicals or spills is not covered.

Glass table top breakage and corrosion or rusting of hardware are not covered.

In addition, purchase parts are not covered under this warranty.

Proof of purchase (dated register receipt) is required for warranty claims.

Warranty (continued)

We reserve the right to make substitutions with similar merchandise, if the model in question is no longer in production.

For a copy of our full limited warranty, please contact our customer service team below.

Contact the Customer Service Team at 1-866-391-4868 or visit www.bjifurniture.com.

Care and Maintenance

- Do not allow water to build up in frames. This will cause corrosion and possible freezing damage in cold climates.
- Use a mild soap and water for normal cleaning. DO NOT use janitorial or alcohol based cleaners. Some cleaners may be marked as natural, but some ingredients can cause discoloration or have adverse reaction to your finish.
- Rinse with clean water and dry with a soft, absorbent cloth towel.
- Cushions, slings, and/or an umbrella may be cleaned by hand with a solution of soap and water with a clean water rinse. Never machine wash as this will result in shrinking or damage. After cleaning, tip on end and allow to drip dry. Never use a commercial or home dryer to tumble dry fabric goods.
- Treat frames with liquid wax for maximum protection against UV rays and / or salty, damp air.
- Umbrella should be closed when not in use. Umbrella should be removed and stored in the event of wind, rain, hail, sleet, snow, or any other inclement weather. To prevent damage to your table, always use an umbrella base with your umbrella. Store indoors during winter months.
- Use and operation: To prolong the life of your outdoor furniture, cover when not in use. Store indoors during winter months.

Pre-Assembly

PLANNING ASSEMBLY

PLEASE READ COMPLETE USE AND CARE GUIDE PRIOR TO ASSEMBLY!

Identify all parts packed in the carton against the parts list. Remove all protective materials and place the parts on a nonabrasive surface to avoid scratching. It takes about 5 minutes for one person to complete all the assembly.



NOTE: Seek assistance to assemble bulky or heavy items.

HARDWARE INCLUDED



NOTE: Hardware not shown to actual size.



Part	Description	Quantity
AA	M6*30mm hex bolt	2
BB	M6 Washer	2
CC	Hex wrench	1

Pre-Assembly (continued)

PACKAGE CONTENTS

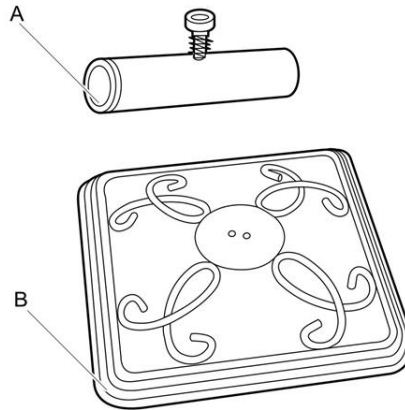

Part	Description	Quantity
A	Support pole with umbrella locking knob (pre-assembled)	1
B	Umbrella base	1

Safety Information

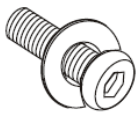

- EVERY BOLT NEEDS TO BE USED WITH A WASHER.
- DO NOT FULLY TIGHTEN BOLT UNTIL INDICATED IN **STEP 1**.

Assembly Instruction

1 Attaching the supporting pole

- Attach the support pole (A) to the base (B) using hex bolts (AA) and M6 washer (BB).
- Tighten completely until all bolts are in place.

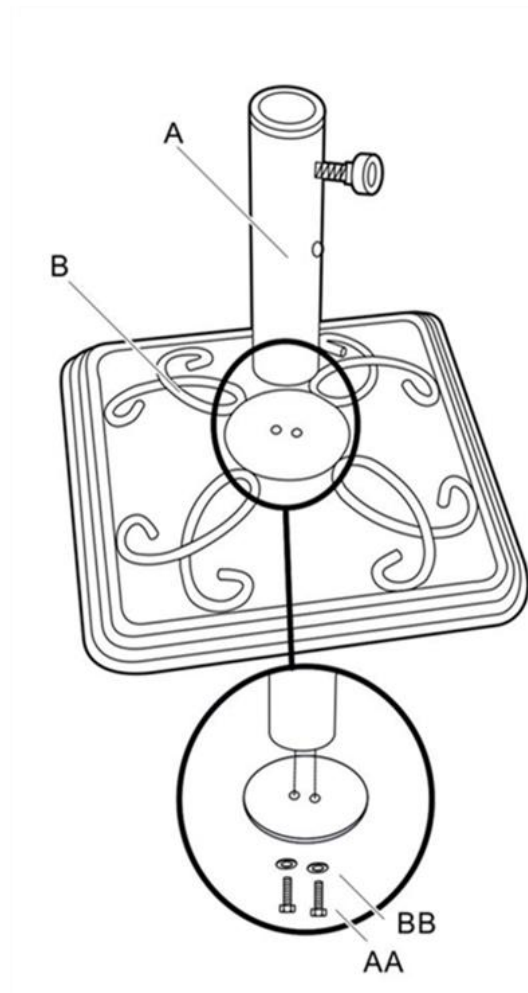

Assembly Instruction (continued)

2 Using with the umbrella

- Insert the umbrella through table top into the umbrella base and secure the umbrella with locking knob.
- Umbrella base is ready for your enjoyment.

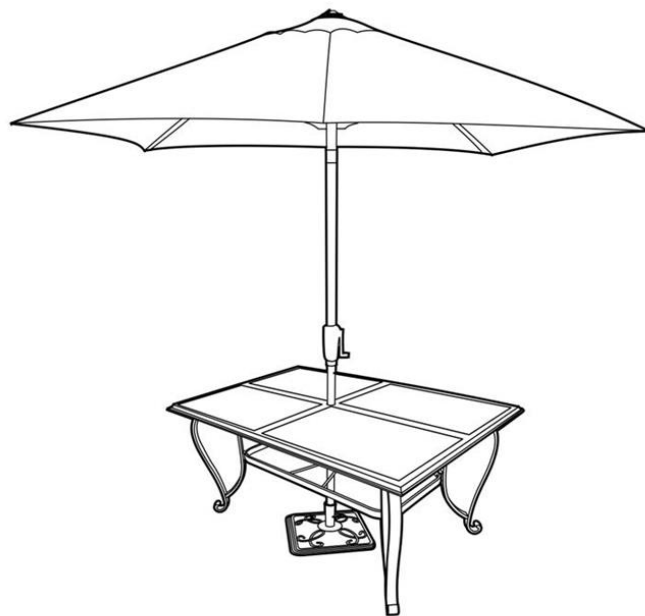

sears

Please refer to part number when reordering

Questions, problems, missing parts? Before returning to the store,
call our Customer Service

8 a.m. - 5 p.m., EST, Monday-Thursday

8 a.m. – 4 p.m., EST, Friday

1-866-391-4868

Made in/ Hecho en CHINA

Distributed by Sears, Roebuck and Co., Hoffman Estates, IL60179

See our extensive assortment of outdoor living products on-line

at www.sears.com and www.kmart.com

Retain this manual for future use.