

USE & CARE GUIDE

Solid 9Ft Umbrella - Yellow

KSN: 08769153-1

UPC Code: 749241315244

Date of purchase: ____/ ____/ ____

Thank you for your purchase

Thank you for your purchase!

We are pleased that you have chosen Kmart for your outdoor furniture purchase. We hope that you enjoy the unmatched quality, comfort, and style of your new patio set. Every piece is meticulously considered all the way down to the smallest details, exclusively for you, by our world class design team. We know you have a choice when it comes to your patio furniture needs, so from our team to yours, thank you for letting us be a part of your outdoors.

Table of contents

Table of Contents	2
Safety Information	3
Set Up your Umbrella Properly	3
Examine your Umbrella	3
Warranty	3
Excluded	3
Service Center	3
Care and Maintenance	4
Pre-Assembly	5
Package Contents	5
Assembly Instructions	6
Customer Service	8

Safety Information

SET UP YOUR UMBRELLA PROPERLY

- Please read and understand this entire manual before attempt to assemble, operate, or install the product.
- If any part is missing or damaged. Do not attempt to assemble the product.
- Do not use the structure as support.
- Keep instructions for future use.

EXAMINE YOUR UMBRELLA

- Examine occasionally to ensure there are no loose parts. If loose parts are found, they should be retightened immediately.

Warranty

1 YEAR WARRANTY FOR FRAME AND FABRIC

Limited warranty is applicable on parts only. Warranty extends solely to the original purchaser who must offer original sales receipt for record.

WHAT IS COVERED

Limited parts warranty covers original purchaser from date of purchase for one year. Warranty ensures umbrella fabric cover and umbrella frame will be free from manufacturing defects.

WHAT IS NOT COVERED

Product used for commercial, contract, or other non-residential purposes, or damage due to acts of nature, vandalism, misuse, or improper assembly is not covered. Corrosion or rusting of hardware is not covered. Warranty is to the original purchaser and is non-transferable. Any replacement of warranted items will be in the original style and color, or a similar style and color if the original is unavailable or has been discontinued.

SERVICE CENTER

The purchaser must contact our customer service center directly if this product is found to be defect in material or workmanship. The manufacturer, as its option, will repair or replace the defectives parts.

Please contact us via 1-800-961-9838, 9AM-5PM, Pacific Time Zone, Monday-Friday, or customerservice@bondvast.com

Care and Maintenance

- For cleaning, use a mild detergent solution and rinse with water. Do not use acetone abrasive or others special detergents to clean and air dry only.
- Due to the nature of aluminum, surface oxidation (rusting) will occur if this protective coating is scratched. This is a natural process. To minimize this condition, it is recommended that care be taken when assembling and handling the product in order to prevent the paint from being scratched.

Pre-Assembly

PLANNING ASSEMBLY

To prevent damage, place all parts on a soft surface during assembly.

Do not leave it unattended if not fully assembled even if bolted to the ground.

Pre-Assembly

Part content

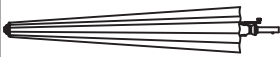
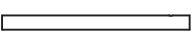
PART	DESCRIPTION	PICTURE	QTY.
A	Umbrella		1
B	Bottom Tube		1

Assembly Instructions

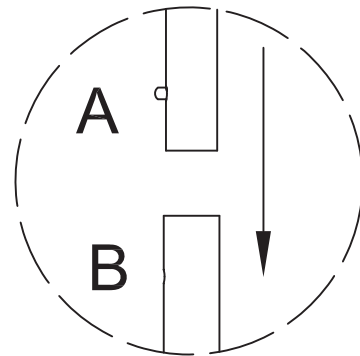
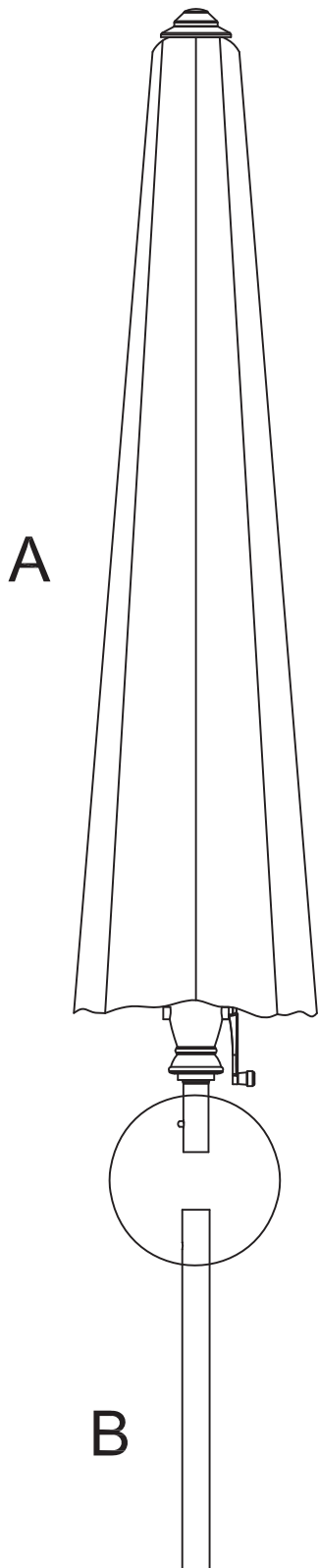

Step 1:
Insert umbrella (A)
into bottom tube (B).
Then secure bottom tube to
umbrella base.
Umbrella base sold separately.

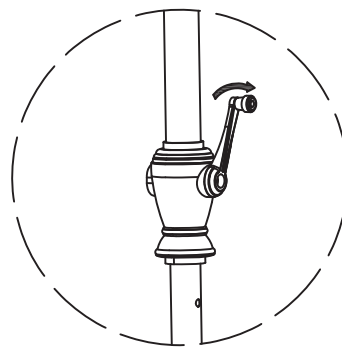

Step 2:
Turn the crank to make
the umbrella canopy to
full extension.

Assembly Instructions

Step 3:

Press the button on the upper portion of the umbrella tube to tilt.



Warning:

To avoid damage to your table: An umbrella base must be used at all time. The umbrella should be removed and stored in the event of wind, rain, hail, sleet, snow, or any other inclement weather.



BOND VAST INDUSTRIAL LIMITED



No. 174 Ding Tan Pi Tan Vill Lutsao Hsiang, Chla Yi Hsien, Tai Wan, ROC

FAX: 886-5-3651 522

CUSTOMER SERVICE HOT LINE: 1-800-961-9838

SERVICE HOURS: MONDAY - FRIDAY 9:00AM - 5:00PM (PACIFIC TIME)

E-MAIL: CUSTOMERSERVICE@BONDVAST.COM



Please refer to part numbers when reordering

For questions or comments about product:

Email: customerservice@bondvast.com or Call toll-free: 1-800-961-9838

Made in / Hecho en CHINA for Kmart Corporation, Hoffman Estates, IL 60179

See our extensive assortment of outdoor living products
on-line at ww.sears.com and www.kmart.com