

MASON GREEN™

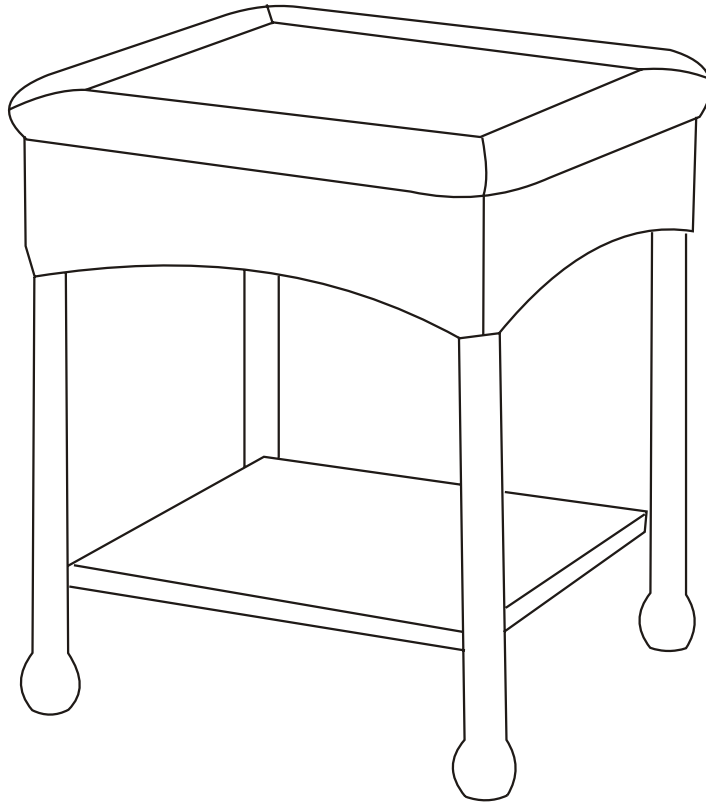

USE AND CARE GUIDE

CORAL SPRINGS SIDE TABLE

Product Code: D71 M20884

KSN: 0-08879693-3

UPC Code: 0-28776-324076

Date of Purchase: ____/____/____

Thank you for your purchase

Thank you for your purchase!

We are pleased that you have chosen Sears for your outdoor furniture purchase. We hope that you enjoy the unmatched quality, comfort, and style of your new patio set. Every piece is meticulously considered all the way down to the smallest details, exclusively for you, by our world class design team. We know you have a choice when it comes to your patio furniture needs, so from our team to yours, thank you for letting us be a part of your outdoors.

Table of Contents

Table of Contents.....	2
Safety Information.....	3
Set Up Your Furniture Properly.....	3
Examine Your Furniture.....	3
Warranty.....	3
What is Covered.....	3
What is Not Covered.....	3
Care and Maintenance.....	4
Pre-Assembly.....	5
Planning Assembly.....	5
Hardware Included.....	5
Observe Weight Limits.....	5
Package Contents.....	6
Assembly Instructions.....	7
Customer Service.....	11

Safety Information

SET UP YOUR FURNITURE PROPERLY

- Ensure that all parts are assembled properly and fully tightened as per instructions.
- When placing in the desired location, ensure that all legs are resting on the same surface. You may adjust the legs levelers as required to ensure that the item stands in a stable position.

EXAMINE YOUR FURNITURE

- Examine occasionally to ensure that there are no loose parts. If loose parts are found, they must be retightened fully before further use.

Warranty

1 YEAR WARRANTY FOR FRAME, RESIN WEAVE AND CUSHIONS

WHAT IS COVERED

We warrant to the original purchaser for one year, from the date of purchase, that the frame, resin weave and cushions will be free from manufacturing defects. This warrant also covers peeling, crackling, blistering, discoloration, or fading for this one year period.

WHAT IS NOT COVERED

It remains the customer's responsibility for freight and packaging charges to and from our service center. This warranty does not cover commercial use, acts of nature, fire, freezing, and abusive use. Discoloration or fading of the finish or fabrics as a result of chemicals or spills is not covered. Glass tabletop breakage and corrosion or rusting of hardware are not covered. In addition, purchased parts are not covered under this warranty. Proof of purchase (dated register receipt) is required for warranty claims. We reserve the right to make substitutions with similar merchandise, if the model is no longer in production. Warranty is to the original purchaser and is not transferable. As some states do not allow exclusions or limitations on an implied warranty, the above exclusions and limitations may not apply. This warranty gives you specific rights, and you may also have other rights, which vary from state to state.

WARRANTY

This limited warranty is extended to the original purchaser and applies to defects in material and workmanship of your patio furniture, provided your furniture is maintained with care and used only for personal, residential purposes.

Resin wicker is warranted to be free from defects in material or workmanship for a period of one (1) year.

Warranty

Cushions are covered for a period of one (1) year against defects in material or workmanship.

Frames are warranted to be free from defects in material or workmanship for a period of one (1) year.

Exclusions: Items used for commercial, contract, or other non-residential purposes, or items damaged due to acts of nature, vandalism, misuse, or improper assembly is not covered. Discoloration and fading of the finish or fabrics as a result of chemicals or spills are not covered. Glass table top breakage and corrosion or rusting of hardware is not covered. If, within the stated warranty period, this product is found to be defective in material or workmanship, the purchaser must contact the customer service department at 1-800-327-2978. The manufacturer, at its option, will repair or replace the defectives parts. Proof of purchase (date register receipt) is required for warranty claims. It remains the customer's responsibility to pay for freight and packing charges to and from the service center. Warranty is to the original purchaser and is non-transferable. Any replacement of warranted items will be in the original style and color, or a similar style and color if the original is unavailable or has been discontinued. As some states do not allow exclusions or limitations on an implied warranty, the above exclusions and limitations may not apply. This warranty gives you specific rights, and you may also have other rights, which vary from state to state.

Care instructions: Protecting furniture from the elements, when not in use is highly recommended. Wipe frame With a lightly damp cloth and dry completely, do not use bleach or solvents. Wash cushions with mild solution of soap and water, rinse thoroughly. Do not machine wash.

Customer service 1-800-327-2978

Care and Maintenance

- ❑ Wash the frame with a mild solution of soap and water, rinse with clean water, and dry thoroughly.
- ❑ Cushions may also be cleaned by hand with a mild solution of soap and water. Rinse the cushion cover thoroughly and allow to drip dry. The back cushion and pillow should be spot cleaned with a soft cloth. Do not machine wash or tumble dry, as cushions may shrink. Do not use bleach or solvents on fabrics. Never use cleaners that contain acid or abrasive materials.
- ❑ Use and operation: To improve the lifespan of this furniture, cover when not use and store in a dry place in the off season.

Pre-Assembly

PLANNING ASSEMBLY

To prevent damage, place all parts on a soft surface during assembly. Remove all protective caps before beginning assembly. It takes about 15 minutes for one person to complete all the assembly.

OBSERVE WEIGHT LIMITS

The recommended weight limits for the following product is listed below:

- Table: 50 lbs



CAUTION: If you overload your furniture, injuries can occur.

HARDWARE INCLUDED



NOTED: Hardware not shown to actual size.

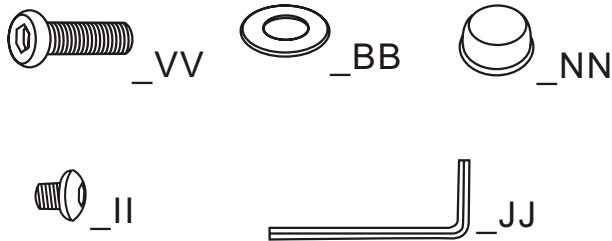

Part	Description	Size	QTY.
VV	BOLTS	(Φ 8x16mm)	4
BB	WASHERS	(Φ 8mm)	4
NN	CAPS FOR BOLTS	(Φ 8mm)	8
II	BOLTS	(Φ 8x12mm)	4
JJ	ALLEN WRENCH	(5mm)	1

Pre-Assembly(continued)

Package Contents

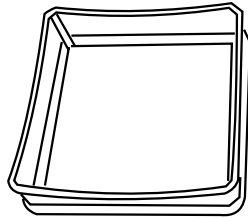

A

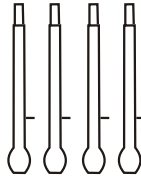

B

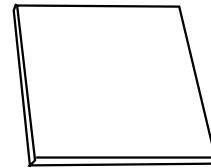

C

PART	DESCRIPTION	QUANTITY
A	TABLE TOP	1
B	LEGS	4
C	LOWER SHELF	1



Safety Information

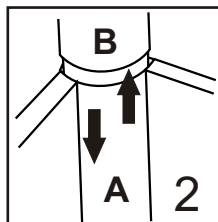
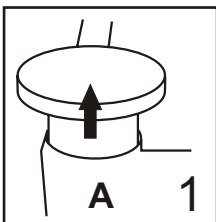

- 1.REMOVE THE PLASTIC PROTECTIVE CAPS BEFORE ASSEMBLY.**
- 2. YOU MAY NEED TO MAKE ADJUSTMENTS TO THE FOUR LEGS ENSURE THAT THE TABLE IS LEVEL.**

Assembly Instructions

1 Attaching the leg to the top

- PUT THE LEGS "B" METAL SIDE INTO THE FOUR HOLES OF TOP "A".
- ATTENTION: THE LEGS "B" MUST BE PUT AS ILLUSTRATED.
- FASTEN WITH BOLTS "II" AND TIGHTEN.

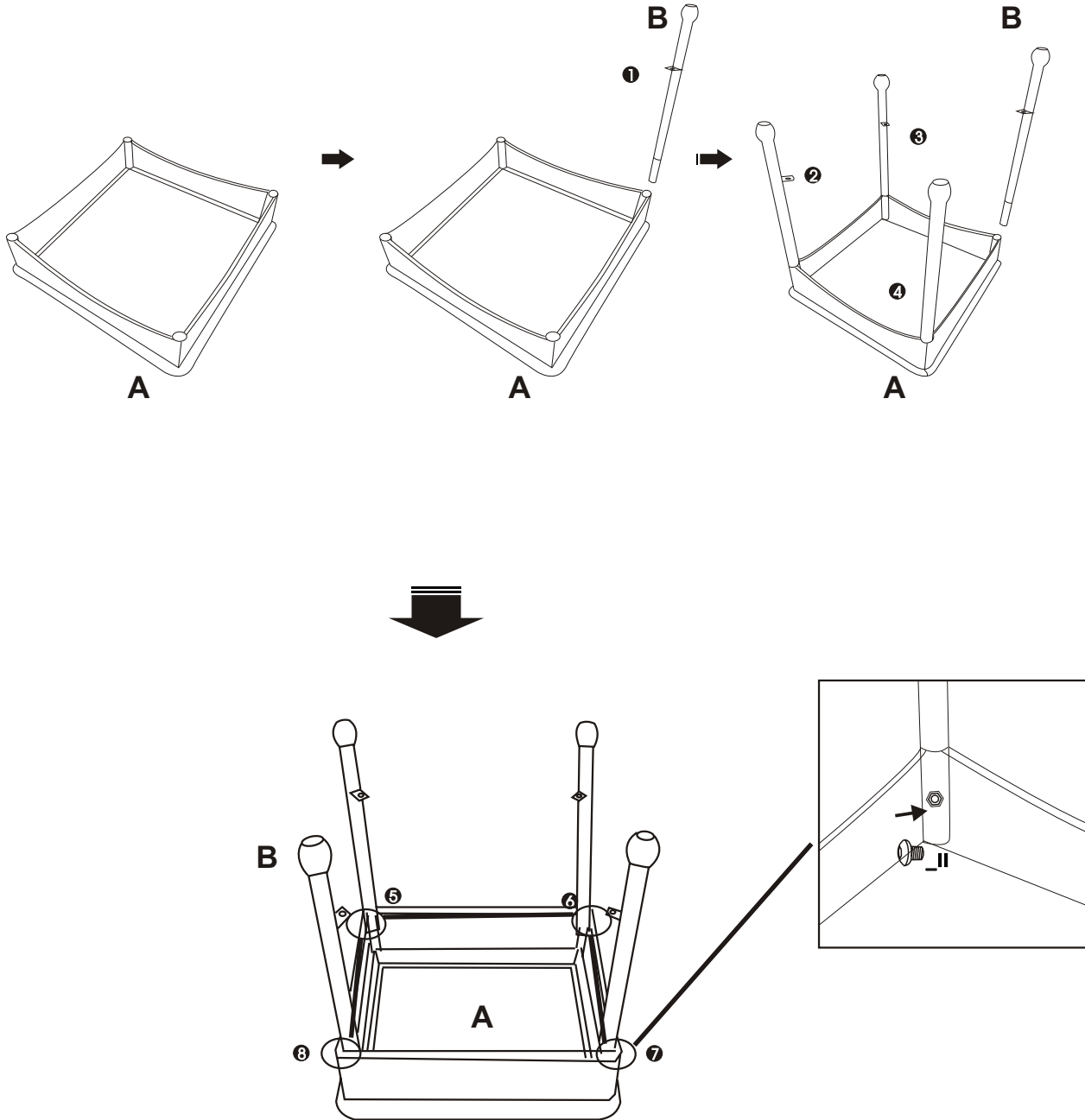

2 Attaching the shelf

- FIX THE HOLES ON SHELF "C" AND LEGS "B" GOING THROUGH THE BRACKET HOLES ON "B", TIGHTEN WITH BOLTS "VV" . HALFWAY USING ALLEN WRENCH "JJ".

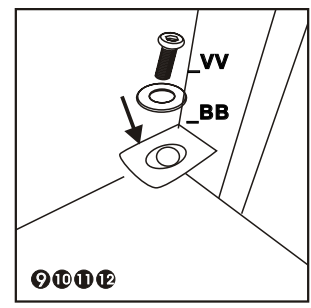
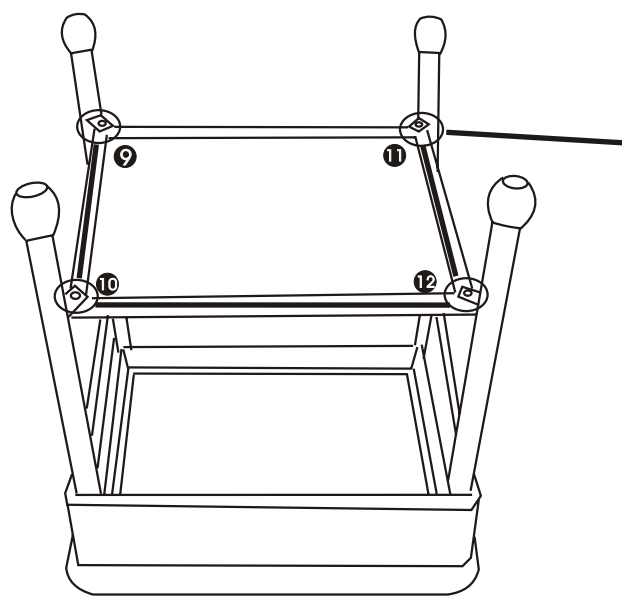
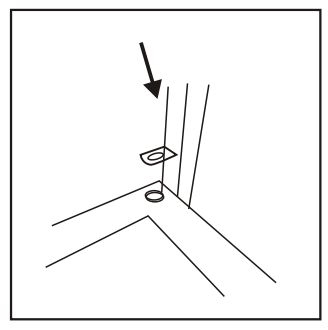
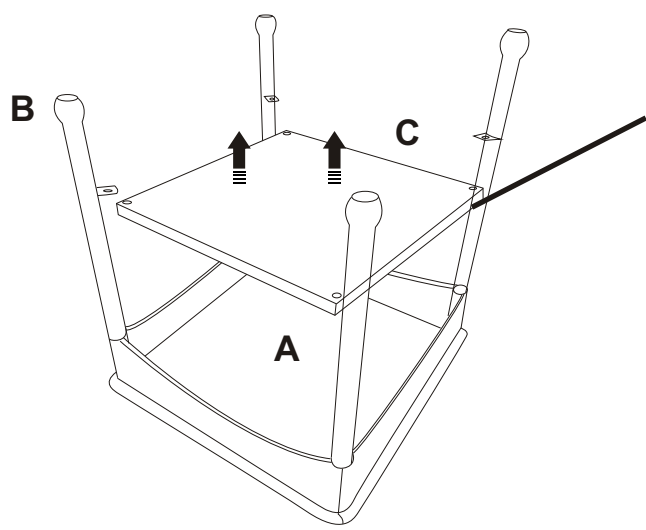

3 Adding the caps

- ❑ CHECK AND MAKE ADJUSTMENT AS NEEDED, FULLY TIGHTEN ALL THE BOLTS WITH ALLEN WRENCH "JJ" .
- ❑ COVER ALL THE BOLTS WITH CAPS "NN".

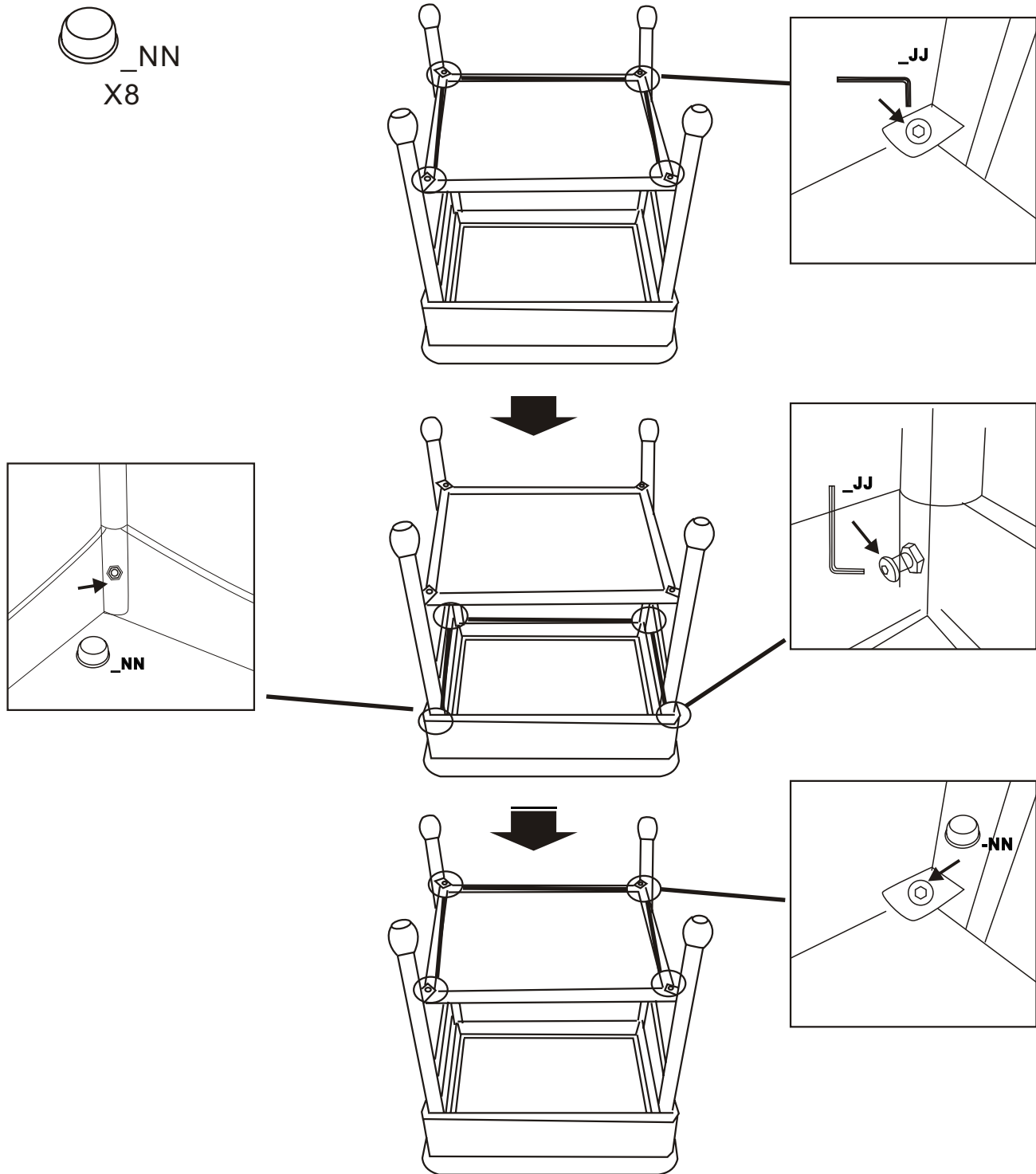
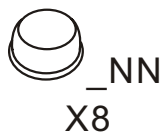

4 Now is ready for your enjoyment

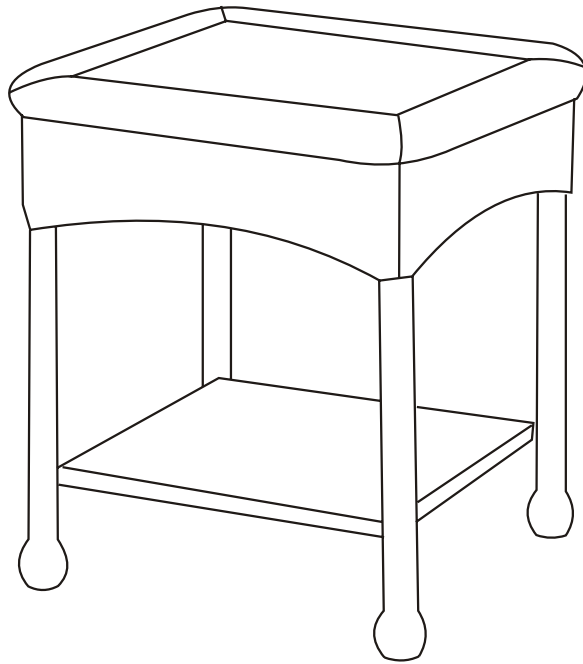

GRAND BASKET CO. INC.
GRAND FAR EAST MANUFACTURING CO., LTD.



HOME OFFICE: 53-06 GRAND AVENUE, MASPETH, NY 11378
FAX: (718) 417-0910
CUSTOMER SERVICE HOT LINE: 1-800-327-2978
SERVICE HOURS: MONDAY-FRIDAY 9:00AM-4:30PM (EST)
E-MAIL: info@grandbasketco.com

sears

Please refer to part numbers when reordering

For questions or comments about product:

Email: info@grandbasketco.com or Call toll-free: 1-800-327-2978

Made in / Hecho en CHINA

Distributed by Sears, Roebuck and Co., Hoffman Estates, IL 60179

sears.com

See our extensive assortment of outdoor living products
on-line at www.sears.com and www.kmart.com