

USE AND CARE GUIDE

Brighton Dining Chairs

Product Code: 0-08786770-1

UPC Code: 095457151207

Date of Purchase: ____/____/____

Thank you for your purchase

Thank you for your purchase!

We are pleased that you have chosen Kmart for your outdoor furniture purchase. We hope that you enjoy the unmatched quality, comfort, and style of your new patio set. Every piece is meticulously considered all the way down to the smallest details, exclusively for you, by our world class design team. We know you have a choice when it comes to your patio furniture needs, so from our team to yours, thank you for letting us be a part of your outdoors.

Table of Contents

Table of Contents	2
Safety Information	3
Set Up Your Furniture Properly.....	3
Examine your furniture.....	3
Warranty	3
What is Covered.....	4
What is Not Covered.....	4
Care and Maintenance	4
Pre-Assembly.....	5
Planning Assembly.....	5
Hardware Included.....	5
Observe weight Limits.....	5
Package Contents.....	6
Assembly Instructions	
Chair.....	7
Swivel Chair.....	9-11
Ottoman.....	13-14
Side Table.....	16-18
Customer Service.....	19

Safety Information

SET UP YOUR FURNITURE PROPERLY

- Ensure that all parts are assembled properly and fully tightened as per the instructions.
- When placing in the desired location, ensure that all legs are resting on the same surface. You may adjust the legs levelers as required to ensure that the item stands in a rigid position.

EXAMINE YOUR FURNITURE

- Examine occasionally to ensure that there are no loose parts. If loose parts are found, they must be retightened fully before additional use.

Warranty

1 YEAR WARRANTY FOR FRAME, RESIN WEAVE AND CUSHIONS

WHAT IS COVERED

We warrant to the original purchaser for one year, from the date of purchase, that the frame, resin weave and cushions will be free from manufacturing defects. This warranty also covers peeling, crackling, blistering, discoloration, or fading for this one year period.

WHAT IS NOT COVERED

It remains the customer's responsibility for freight and packaging charges to and from our service center. This warranty does not cover commercial use, acts of nature, fire, freezing, and abusive use. Discoloration or fading of the finish or fabrics as a result of chemicals or spills is not covered. Glass tabletop breakage and corrosion or rusting of hardware are not covered. In addition, purchased parts are not covered under this warranty. Proof of purchase (dated register receipt) is required for warranty claims. We reserve the right to make substitutions with similar merchandise, if the model is no longer in production. Warranty is to the original purchaser and is not transferable. As some states do not allow exclusions or limitations on an implied warranty, the above exclusions and limitations may not apply. This warranty gives you specific rights, and you may also have other rights, which vary from state to state.

WARRANTY

This limited warranty is extended to the original purchaser and applies to defects in material and workmanship of your patio furniture, provided your furniture is maintained with care and used only for personal, residential purposes.

Resin wicker is warranted to be free from defects in material or workmanship for a period of one (1) year.

Warranty

Cushions are covered for a period of one (1) year against defects in material or workmanship.

Frames are warranted to be free from defects in material or workmanship for a period of one (1) year.

Exclusions: items used for commercial, contract, or other nonresidential purposes, or items damaged due to acts of nature, vandalism, misuse, or improper assembly is not covered. Discoloration and fading of the finish or fabrics as a result of chemicals or spills are not covered. Glass table top breakage and corrosion or rusting of hardware are not covered. If within the stated warranty period, this product is found to be defective in material or workmanship, the purchaser must contact the manufacturer's customer service department. The manufacturer, at its option, will repair or replace the defectives parts. Proof of purchase (date register receipt) is required for warranty claims. It remains the customer's responsibility to pay for freight and packing charges to and from the service center. Warranty is to the original purchaser and is nontransferable.

Any replacement of warranted items will be in the original style and color, or a similar style and color if the original is unavailable or has been discontinued. As some states do not allow exclusions or limitations on an implied warranty, the above exclusions and limitations may not apply. This warranty gives you specific rights, and you may also have other rights, which vary from state to state.

Care instructions: protecting furniture from the elements, when not in use is highly recommended. Wipe frame with a lightly damp cloth and dry completely, do not use bleach or solvents. Wash cushions with mild solution of soap and water, rinse thoroughly. Do not machine wash.

Customer service 1-800-585-9969

Care and Maintenance

- Wash the frame with a mild solution of soap and water, rinse with clean water and dry thoroughly.
- Cushions may also be cleaned by hand with a mild solution of soap and water. Rinse the cushion cover thoroughly and allow to drip dry. The back cushion and pillow should be spot cleaned with a soft cloth. Do not machine wash or tumble dry as cushions may shrink. Do not use bleach or solvents on fabrics. Never use cleaners that contain acid or abrasive materials.
- Use and operation: To improve the lifespan of this furniture, cover when not use and store in a dry place in the off season.

Pre-Assembly

PLANNING ASSEMBLY

To prevent damage, place all parts on a soft surface during assembly. Remove all protective caps before beginning assembly. It takes about 90 minutes for two person to complete all the assembly.

OBSERVE WEIGHT LIMITS

The recommended weight limits for the following products are listed below:

- Dining Chair: 250 lbs
- Swivel Chair: 250 lbs
- Ottoman: 150 lbs
- Side Table: 40 lbs



CAUTION: If you overload your furniture, injuries can occur.

HARDWARE INCLUDED



NOTED: Hardware not shown to actual size.

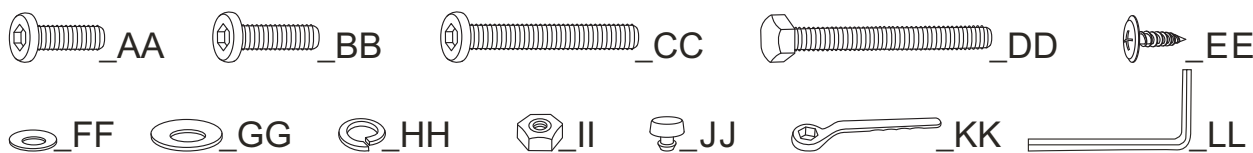

Part	Description	Size	QTY.
AA	BOLTS	(Φ 6.35x14mm)	24
BB	BOLTS	(Φ 6.35x16mm)	8
CC	BOLTS	(Φ 6.35x30mm)	48
DD	HEXAGONAL BOLTS	(Φ 8x38mm)	8
EE	SCREWS	(4x12mm)	4
FF	SMALL WASHERS	(Φ 13mm)	80
GG	BIG WASHERS	(Φ 22mm)	8
HH	SPRING WASHERS	(Φ 14mm)	8
II	NUTS	(Φ 6.2mm)	8
JJ	PUSH PINS	(5mm)	4
KK	WRENCH	(4mm)	2
LL	ALLEN WRENCH	(4mm)	1

Package Contents

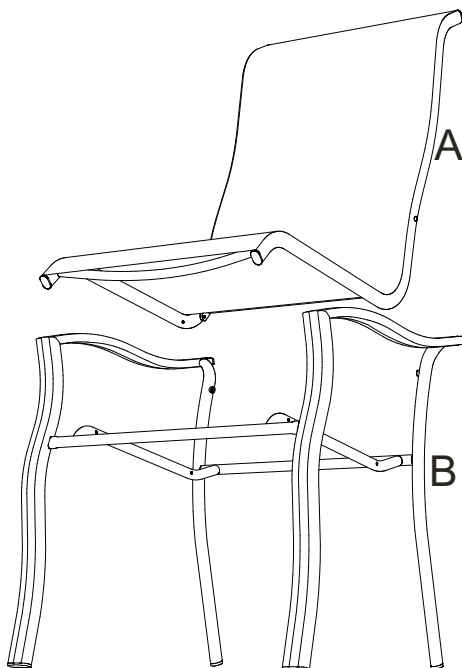

PART	DESCRIPTION	QUANTITY
A	SEAT BACK	4
B	CHAIR BASE	4



Safety Information

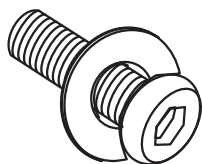

1. EVERY BOLT NEEDS TO BE USED WITH A WASHER.
2. DO NOT FULLY TIGHTEN BOLTS UNTIL INDICATED IN STEP 1.

Assembly Instructions

1 Attaching chair base to chair seat back

- ATTACH THE CHAIR BASE "B" TO SEAT BACK "A" BY USING SIX 30MM BOLTS "CC" AND SIX SMALL WASHERS "FF", TIGHTEN HALF THE WAY USING ALLEN WRENCH "LL".

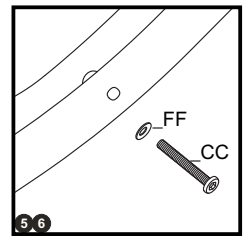
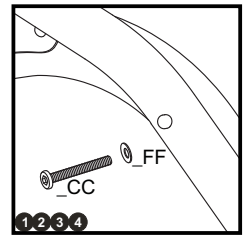
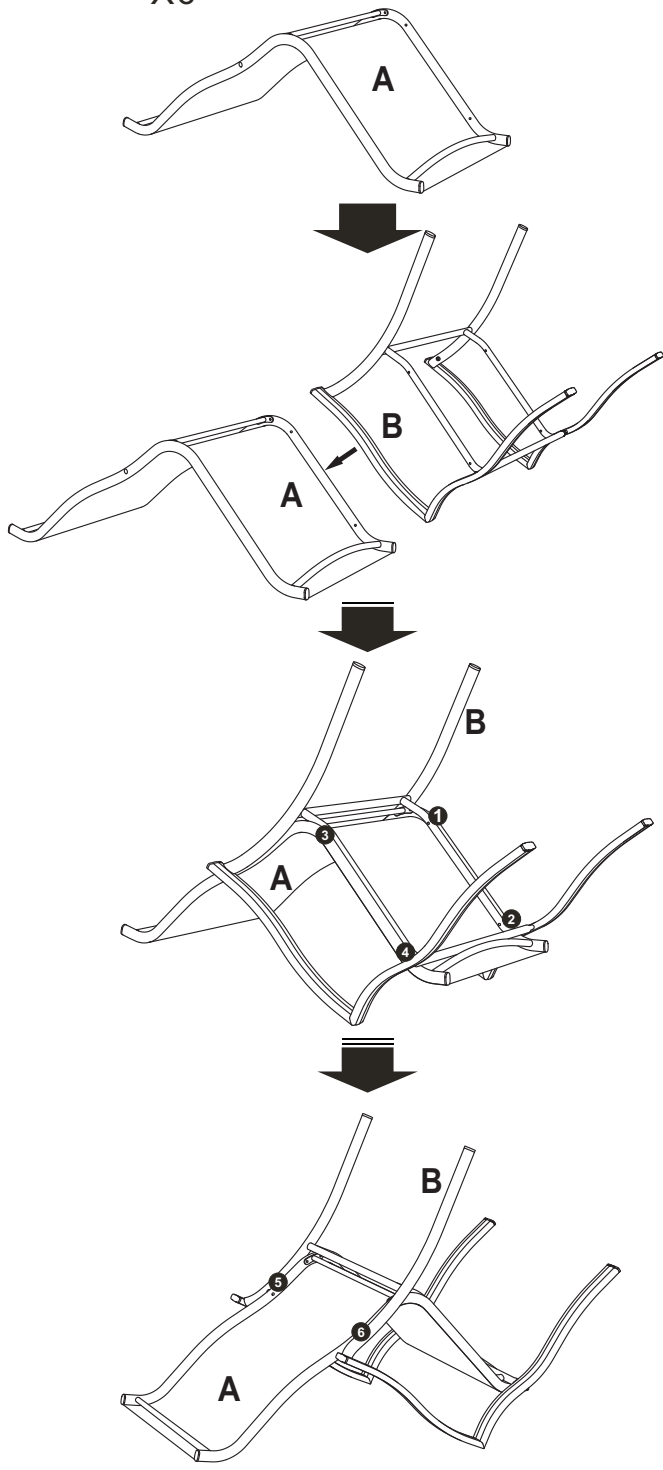
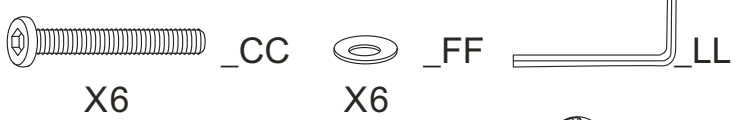

Pre-Assembly (continued)

Package Contents

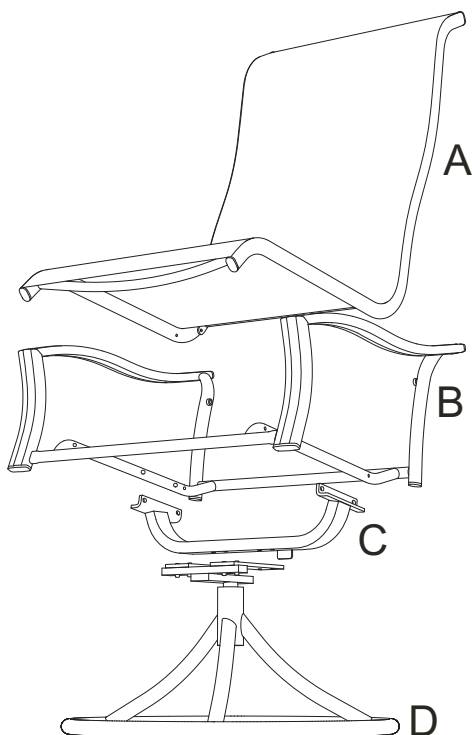

PART	DESCRIPTION	QUANTITY
A	SEAT BACK	2
B	SEAT FRAME	2
C	U SUPPORT	2
D	CHAIR BASE	2



Safety Information

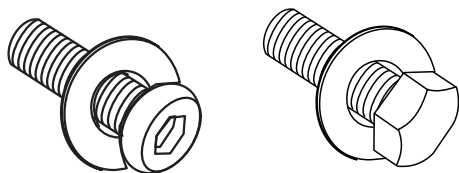

1. EVERY BOLT NEEDS TO BE USED WITH A WASHER.
2. DO NOT FULLY TIGHTEN BOLTS UNTIL INDICATED IN STEP 3.

Assembly Instructions

1 Attaching chair seat frame

- ATTACH THE SEAT FRAME "B" TO SEAT BACK "A" BY USING SIX 30MM BOLTS "CC" AND SIX SMALL WASHERS "FF", TIGHTEN HALF THE WAY USING ALLEN WRENCH "LL" .

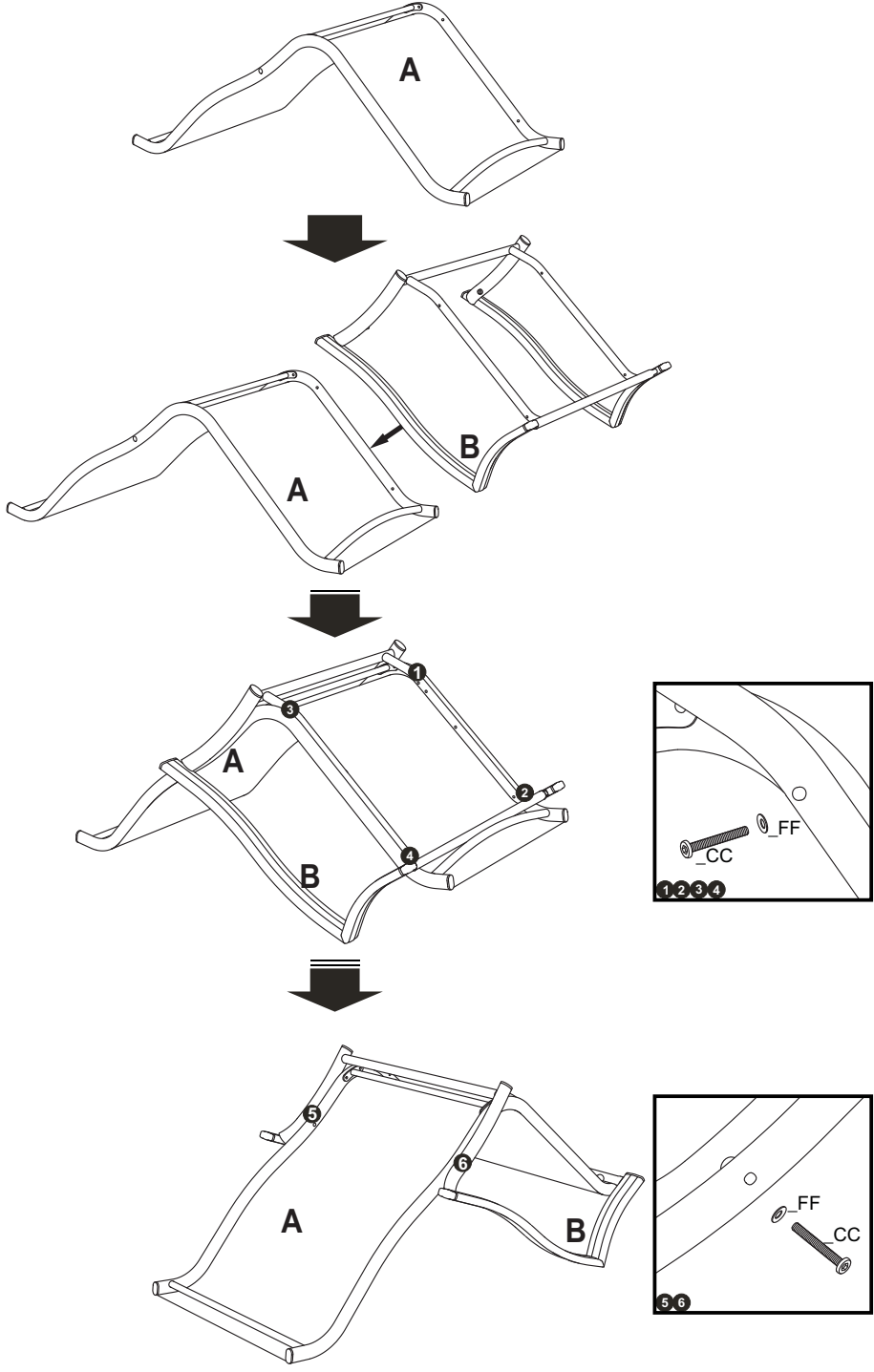
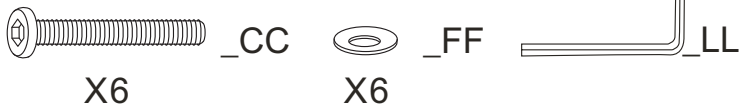

Assembly Instructions

2 Attaching the u support

- ATTACH U SUPPORT "C" TO THE SEAT FRAME "B" BY USING FOUR 16MM BOLTS "BB" AND FOUR SMALL WASHERS "FF", TIGHTEN HALF THE WAY USING ALLEN WRENCH "LL".

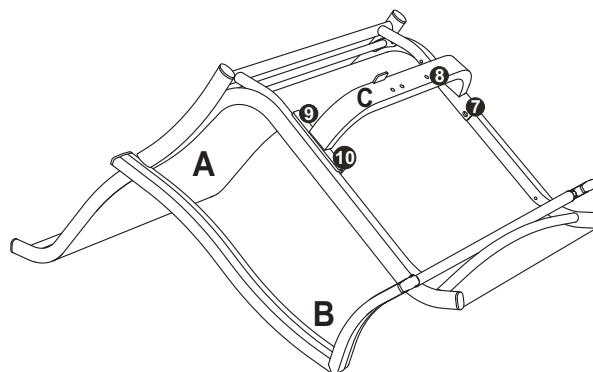
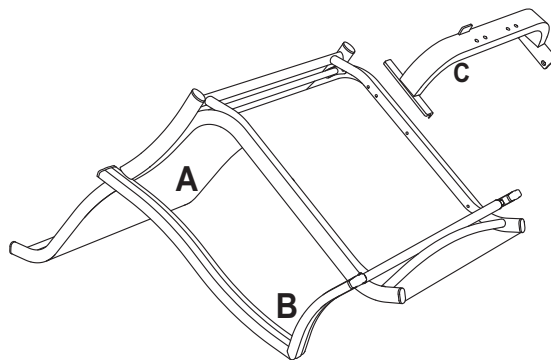
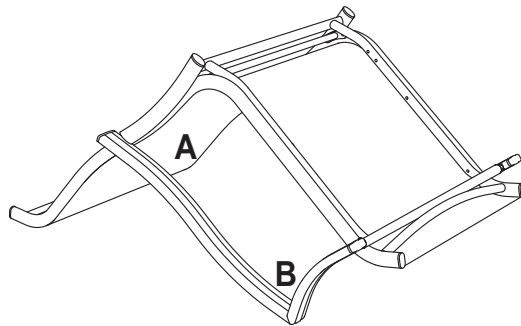
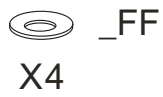
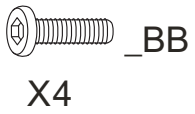

Assembly Instructions

3 Attaching the chair base

- ATTACH CHAIR BASE "D" TO THE U SUPPORT "C" BY USING FOUR 38MM HEXAGONAL BOLTS "DD", FOUR BIG WASHERS "GG", FOUR SPRING WASHERS "HH" AND FOUR NUTS "II". USING THE WRENCH "KK" FULLY TIGHTEN ALL THE BOLTS AND NUTS.

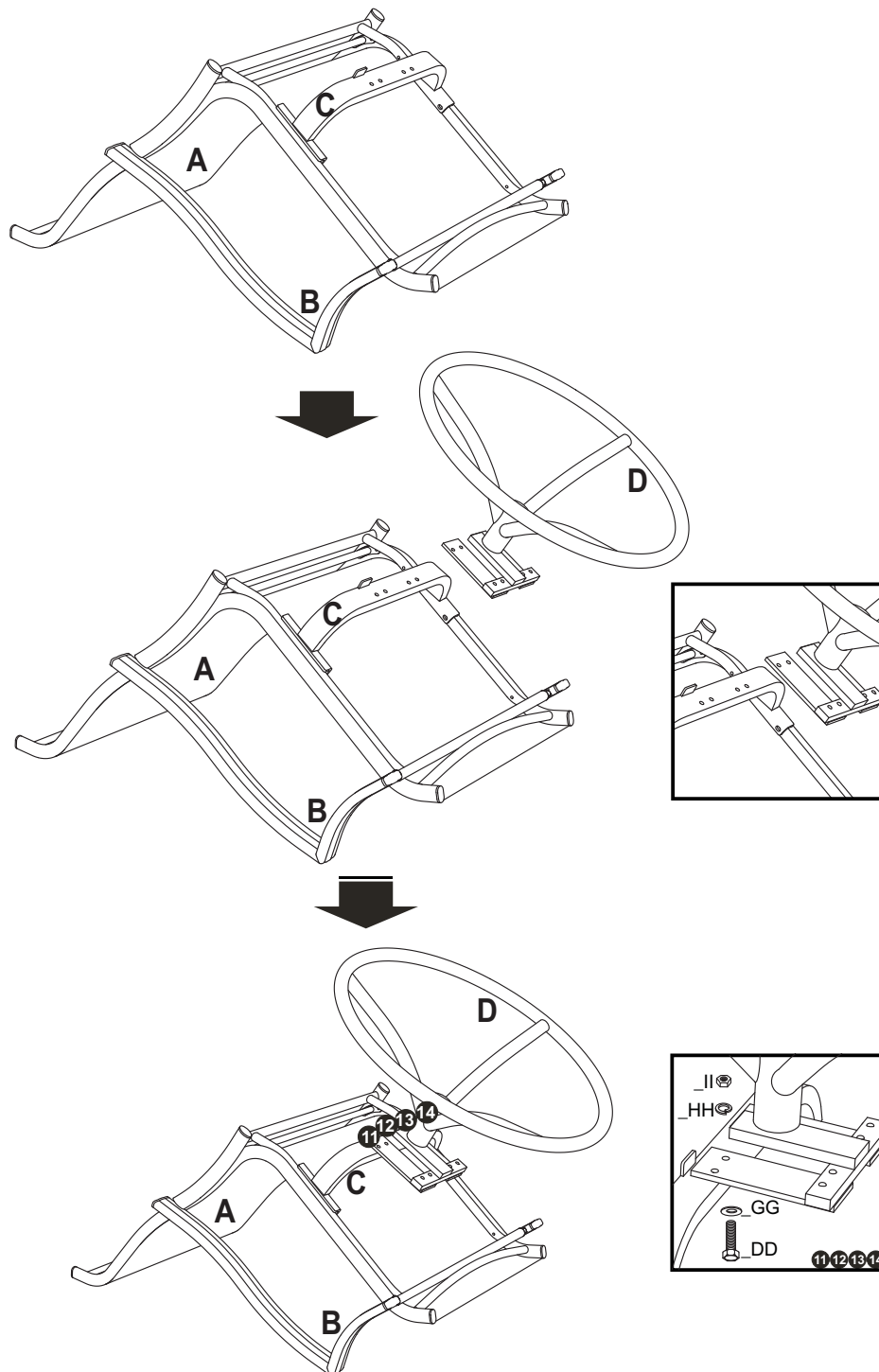
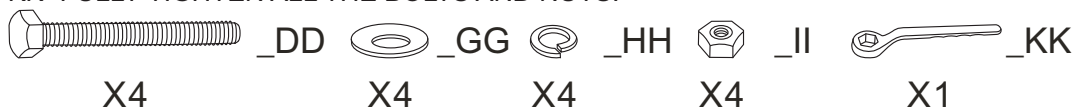

Package Contents

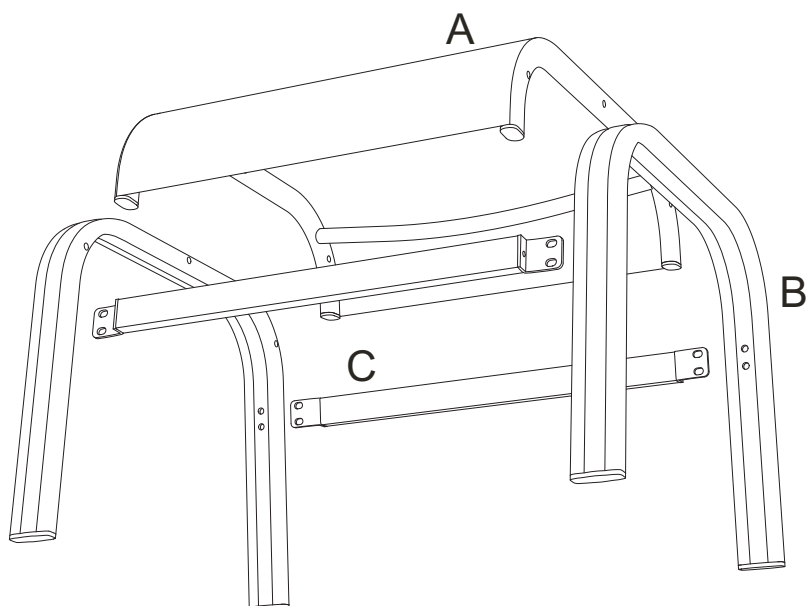

PART	DESCRIPTION	QUANTITY
A	OTTOMAN TOP	2
B	THE LEGS	4
C	CROSS BARS	4



Safety Information

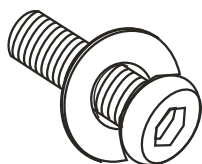

1. EVERY BOLT NEEDS TO BE USED WITH A WASHER.
2. DO NOT FULLY TIGHTEN BOLTS UNTIL INDICATED IN STEP 2.

Assembly Instructions

1 Attaching the legs

- ATTACH THE LEGS "B" TO OTTOMAN TOP "A" BY USING SIX 30MM BOLTS "CC" AND SIX SMALL WASHERS "FF", TIGHTEN HALF THE WAY USING ALLEN WRENCH "LL".

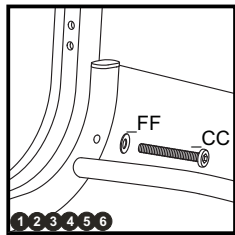
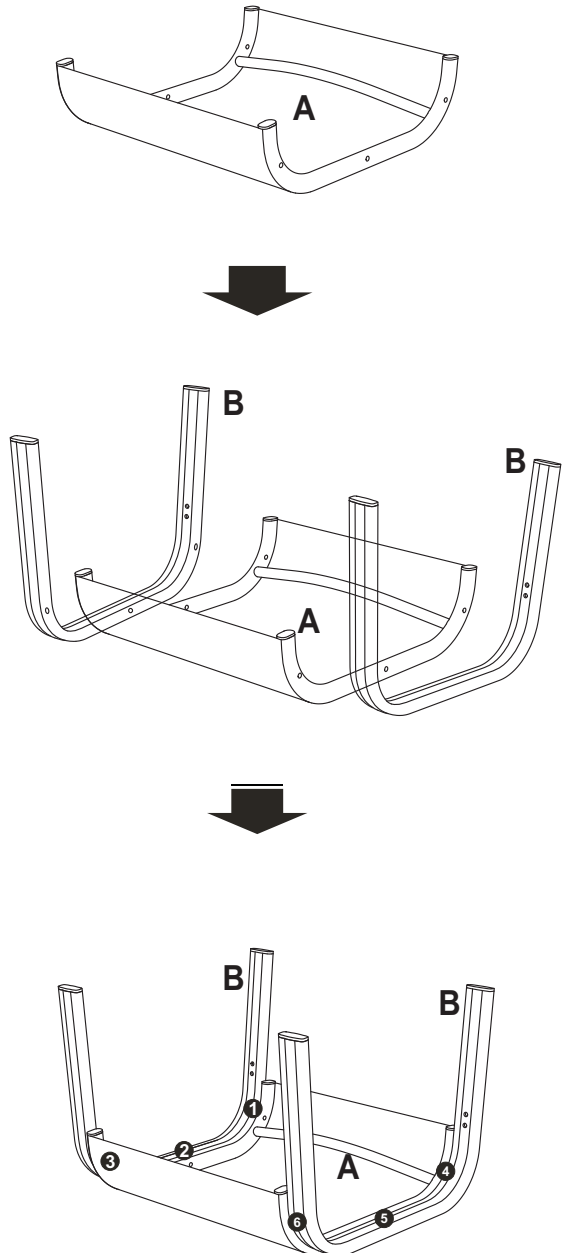
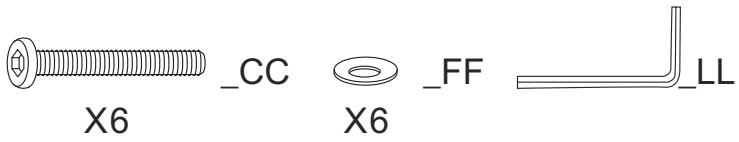

Assembly Instructions

2 Attaching the cross bars

- ATTACH CROSS BARS "C" TO THE LEGS "B" BY USING EIGHT 14MM BOLTS "AA" AND EIGHT SMALL WASHERS "FF", USING THE ALLEN WRENCH "LL" FULLY TIGHTEN ALL THE BOLTS.

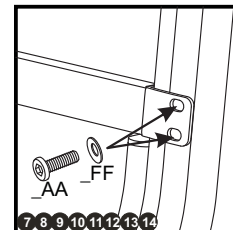
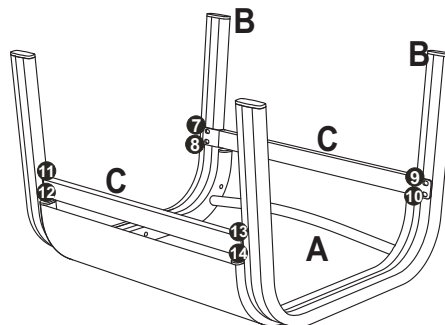
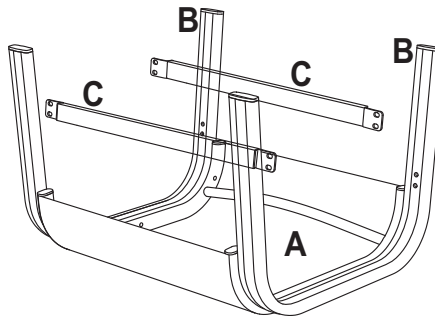
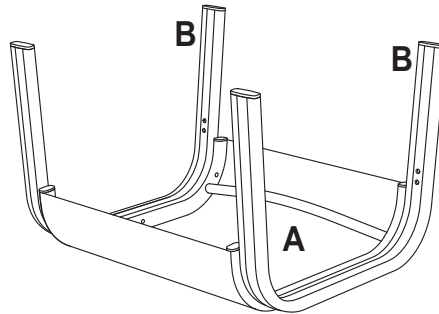
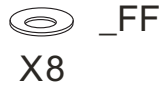
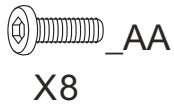

Package Contents

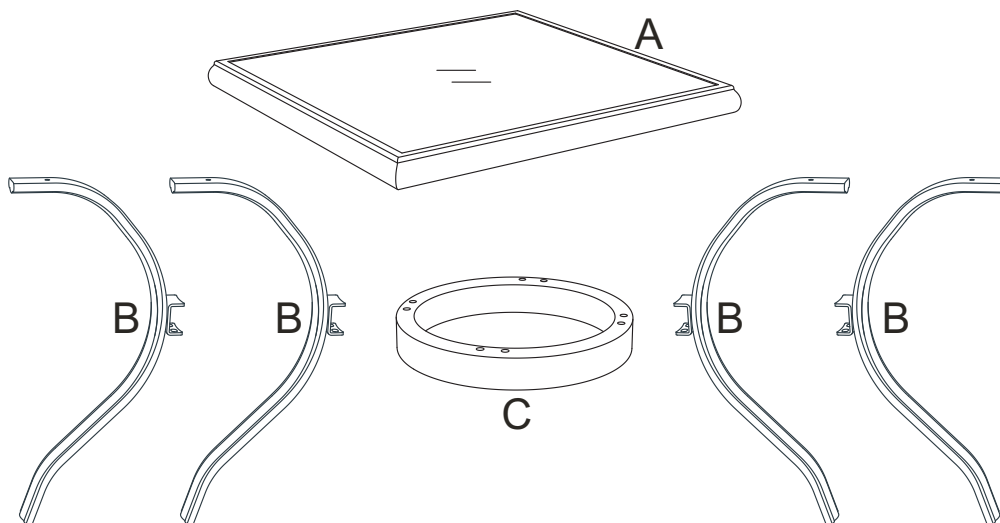

PART	DESCRIPTION	QUANTITY
A	THE TOP OF TABLE	1
B	THE LEG OF TABLE	4
C	THE SUPPORT OF TABLE	1



Safety Information

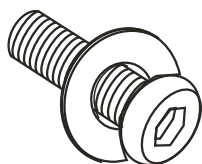

1. EVERY BOLT NEEDS TO BE USED WITH A WASHER.
2. DO NOT FULLY TIGHTEN BOLTS UNTIL INDICATED IN STEP 3.

Assembly Instructions

1 Insert the push pins

- INSET FOUR PUSH PINS "JJ" INTO THE HOLES ON LEGS "B".

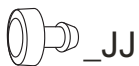

X4

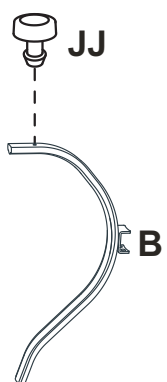

Assembly Instructions

2 Attaching the legs

□ ATTACH FOUR LEGS “ B ” TO THE TABLE TOP “ A ” BY USING FOUR 12MM SCREWS “ EE ”.

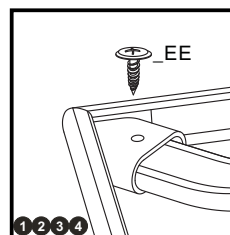
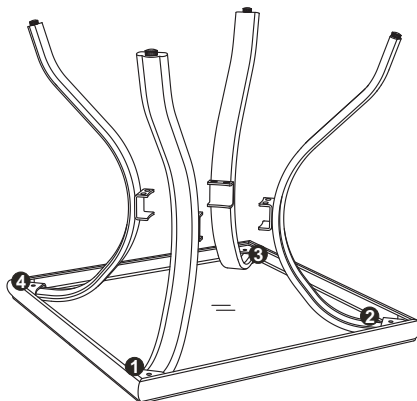
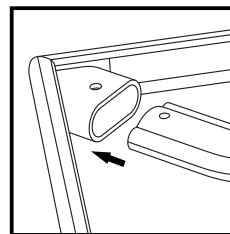
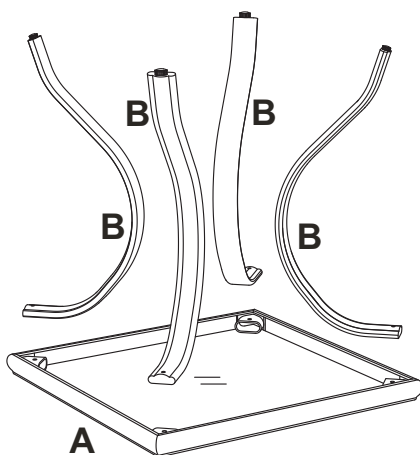
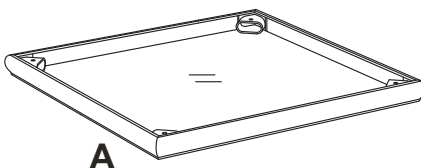
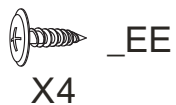

Assembly Instructions

3 Attaching the table support

- ATTACH THE TABLE SUPPORT “C” TO THE LEGS “B” BY USING EIGHT 14MM BOLTS “AA” AND EIGHT SMALL WASHERS “FF”, USING THE ALLEN WRENCH “LL” FULLY TIGHTEN ALL THE BOLTS.
- TURN THE TABLE OVER TO UPRIGHT POSITION.
- THE TABLE IS READY TO USE.

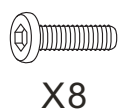

_AA

X8



_FF

X8



_LL

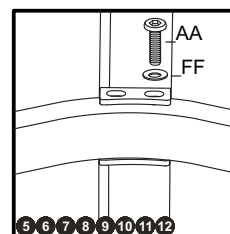
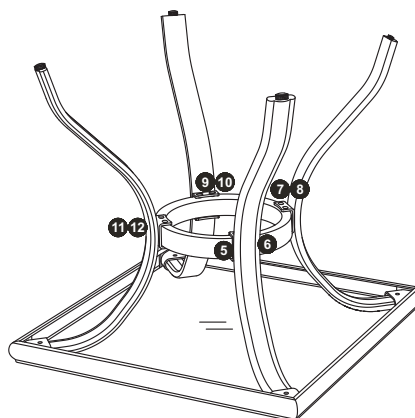
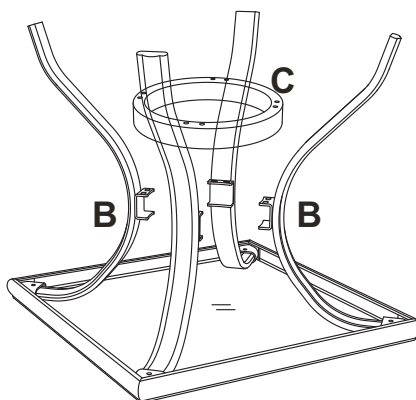
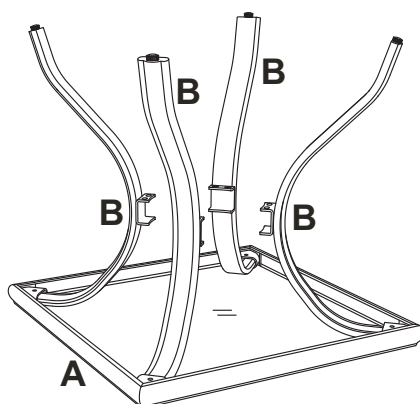



SHINCREST PTE.,LTD.
TSY Services, LLC.



HOME OFFICE: 13033 Arctic Circle, Santa Fe Springs, CA 90670
FAX: (562)376-8364
CUSTOMER SERVICE HOT LINE: 1-800-585-9969
SERVICE HOURS: MONDAY - FRIDAY 8:30 AM - 4:30 PM (EST)
E-MAIL: service@tsyservices.com



Please refer to part numbers when reordering

For questions or comments about product:

Email: service@tsyservices.com or Call toll-free: 1-800-585-9969

Made in / Hecho en CHINA for Kmart Corporation, Hoffman Estates, IL 60179

See our extensive assortment of outdoor living products
on-line at www.sears.com and www.kmart.com