

POWERPRO

T E C H N O L O G Y™

OPERATOR'S MANUAL

4 Gallon Twin Tank Air Compressor

Model # 22040



⚠ IMPORTANT:

Your new tool has been engineered and manufactured to the PowerPro Technology® high standards for dependability, ease of operation, and operator safety. Properly cared for, it will give you years of rugged, trouble-free performance.

Pay close attention to the Rules for Safe Operation, Warnings, and Cautions. If you use your tool properly and only for what it is intended, you will enjoy years of safe, reliable service.

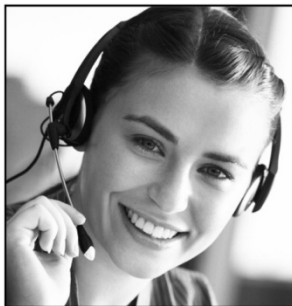

**Product questions or technical support?
Please feel free to contact us!**



WenProducts.com



800- 232-1195 M-F 8:00-5:00 CST



techsupport@wenproducts.com

AIR COMPRESSOR IDENTIFICATION

For information and questions contact customer service at 1-800-232-1195. Please fill out the information below and have it accessible prior to calling. For the Serial Number refer to the specifications sticker on your Air Compressor.

DATE OF PURCHASE: _____

PURCHASED FROM: _____

ITEM #: _____

SERIAL NUMBER: _____

TABLE OF CONTENTS

Specifications	3
Important Safety Instructions.....	4
General Safety Instructions.....	4-6
Air Compressor Safety Information	6-7
Electrical Instructions.....	7-9
Components.....	10
Assembly Instructions.....	11
Operation.....	12-13
Maintenance.....	13-15
Troubleshooting.....	15
Service.....	16
Exploded View.....	17
Parts List.....	18
Warranty.....	19

SPECIFICATIONS

4 Gallon Twin Tank Air Compressor

Item #:	22040
Motor:	120V, 60Hz, 13 Amps
Pressure Range:	85–125 psi
Air Flow:	4.2 CFM @ 40 psi 3.2 CFM @ 90 psi
Air Outlet Size:	1/4" NPT
Tank Capacity:	4 Gallons
Weight:	52 lbs.

IMPORTANT SAFETY INSTRUCTIONS

1. The purpose of safety symbols is to attract your attention to possible dangers. The safety symbols, and the explanations with them, deserve your careful attention and understanding. The safety warnings do not by themselves eliminate any danger. The instructions or warnings they give are not substitutes for proper accident prevention measures.



WARNING: This is the safety alert symbol. It is used to alert you to potential personal injury hazards. Obey all safety messages that follow this symbol to avoid possible injury or death.

Note: Advises you of information or instructions vital to the operation or maintenance of the equipment.

2. Servicing requires extreme care and knowledge and should be performed only by a qualified service technician. For service we suggest you return the tool/equipment to Power Pro for repair. When servicing, use only identical Power Pro replacement parts.
3. **READ ALL INSTRUCTIONS BEFORE USING YOUR AIR COMPRESSOR.**
4. Failure to follow all instructions listed below may result in electrical shock, fire and/or serious personal injury.



WARNING: Do not attempt to operate this tool/equipment until you have read thoroughly and understand completely all instructions, safety rules, contained in this manual. Failure to comply can result in accidents involving fire, electric shock, or serious personal injury. Save this Operator's Manual and review frequently for continuing safe operation and instructing others who may use this tool/equipment.

5. Safe operation of this tool/equipment requires that you read and understand this Operator's Manual and all labels affixed to the tool/equipment. Safety is a combination of common sense, staying alert and knowing how your tool/equipment works.

GENERAL SAFETY INSTRUCTIONS

WARNING: Read all safety warnings and instructions. Failure to follow the warnings and instructions may result in electric shock, fire and/or serious injury.

SAVE ALL WARNINGS AND INSTRUCTIONS FOR FUTURE REFERENCE.

Work Area Safety

1. Keep work area clean and well lit. Cluttered or dark areas invite accidents.
2. Do not operate your Air Compressor in explosive atmospheres, such as in the presence of flammable liquids, gases or dust. Air Compressor motors produce sparks which may ignite the dust or fumes.
3. Keep children and bystanders away from an operating Air Compressor.

Electrical Safety

1. Air Compressor plugs must match the outlet. Never modify the plug in any way. Do not use any adapter plugs with grounded Air Compressors. Standard plugs and matching outlets will reduce the risk of electric shock.
2. Do not expose your Air Compressor to rain or wet conditions. Water entering your Air Compressor will increase the risk of electric shock.
3. Do not abuse the cord. Never use the cord for unplugging your Air Compressor. Keep the cord away from heat, oil, sharp edges or moving parts. Damaged or entangled cords increase the risk of electric shock.

Personal Safety

1. Stay alert, watch what you are doing and use common sense when operating your Air Compressor. Do not use your Air Compressor while you are tired or under the influence of drugs, alcohol or medication. A moment of inattentiveness while operating your Air Compressor may result in serious personal injury.
2. Use protective safety equipment. Always wear ANSI-approved eye protection during setup and use.
3. Prevent unintentional starting. Ensure the switch is in the OFF position before connecting to power source or moving your Air Compressor.

Air Compressor Use and Care

1. Do not use your Air Compressor if the switch does not turn ON and OFF. An Air Compressor that cannot be controlled with the switch is dangerous and must be repaired.
2. Disconnect the plug from the power source before making any adjustments, changing accessories, or storing your Air Compressor. This preventive safety measure reduces the risk of starting your Air Compressor accidentally.
3. Store your Air Compressor out of the reach of children and do not allow people unfamiliar with your Air Compressor or these instructions to operate it. An Air Compressor is dangerous in the hands of untrained users.

4. Maintain your Air Compressor. Keep your Air Compressor clean for maximum performance. Follow the instructions for lubricating and changing accessories. Keep your Air Compressor dry, clean and free from oil and grease. Check for misalignment or binding of moving parts, breakage of parts and any other condition that may affect your Air Compressor's operation. If damaged, have your Air Compressor repaired professionally before use. Many accidents are caused by a poorly maintained Air Compressor.
5. Use your Air Compressor in accordance with these instructions, taking into account the working conditions and the work to be performed. Use of your Air Compressor for operations different from those intended could result in a hazardous situation.

Service

Have your Air Compressor serviced by a qualified professional repair person using only identical replacement parts. This will ensure that the safety of your Air Compressor is maintained.

AIR COMPRESSOR SAFETY INFORMATION

1. RISK OF FIRE OR EXPLOSION – Do not spray flammable liquid in a confined area or towards a hot surface. The spray area must be well-ventilated. Do not smoke while spraying or spray where spark or flame is present.
2. ARCING PARTS – Keep your Air Compressor at least 20 feet away from explosive vapors, such as when spraying with a spray gun.
3. RISK OF BURSTING – Do not adjust regulator higher than marked maximum pressure of attached pneumatic tool/equipment.
4. RISK OF INJURY – Do not direct air stream at people or animals.
5. Do not use to supply breathing air.
6. Do not leave your Air Compressor unattended for an extended period while plugged in. Unplug your Air Compressor after use.
7. Keep your Air Compressor well-ventilated and do not cover during use.
8. Drain tank daily or after use. Internal rust causes tank failure and explosion.
9. Your Air Compressor's cylinder head and air lines get hot during operation. Do not touch or allow children nearby during or immediately following operation.
10. Do not use the air hose to move your Air Compressor.
11. Release the pressure in the storage tank before moving.
12. The use of accessories or attachments not recommended by the manufacturer may result in bodily injury.
13. All air line components, including hoses, pipe, connectors, and filters must be rated for a minimum working pressure of 150% of the maximum system pressure.
14. Industrial applications must follow OSHA guidelines.

15. This product is not a toy. Keep it out of reach from children.
16. People with pacemakers should consult their physician(s) before use. Electromagnetic fields in close proximity to heart pacemaker could cause pacemaker interference or pacemaker failure.



WARNING: The brass components of this product contain lead, a chemical known to the State of California to cause birth defects (or other reproductive harm). (California Health & Safety code 25249.5, et seq.)

17. The warnings, precautions, and instructions discussed in this Operator's Manual cannot cover all possible conditions and situations that may occur. It must be understood by the operator that common sense and caution are factors which cannot be built into this product, but must be supplied by the operator.

ELECTRIC INSTRUCTIONS

Grounding Instructions

1. IN THE EVENT OF A MALFUNCTION OR BREAKDOWN, grounding provides the path of least resistance for electric current and reduces the risk of electric shock. This tool/equipment is equipped with an electric cord that has an equipment grounding conductor and a grounding plug. The plug **MUST** be plugged into a matching outlet that is properly installed and grounded in accordance with ALL local codes and ordinances.
2. **DO NOT MODIFY THE PLUG PROVIDED.** If it will not fit the outlet, have the proper outlet installed by an electrician.
3. **IMPROPER CONNECTION** of the equipment grounding conductor can result in electric shock. The conductor with the green insulation (with or without yellow stripes) is the equipment grounding conductor. If repair or replacement of the electric cord or plug is necessary, **DO NOT** connect the equipment grounding conductor to a live terminal. **CHECK** with a licensed electrician or service personnel if you do not completely understand the grounding instructions, or if you are not sure if the tool/equipment is properly grounded.
4. **USE ONLY THREE WIRE EXTENSION CORDS** with have 3-prong plugs and 3-prong outlets that accept the tool/equipment's plug. Repair or replace damaged or worn cords immediately.
5. **CAUTION:** In all cases, make certain the outlet is properly grounded. If you are not sure if it is, have a licensed electrician check the outlet.



WARNING: This tool/equipment is for indoor use only. Do not expose to rain or use in damp locations.

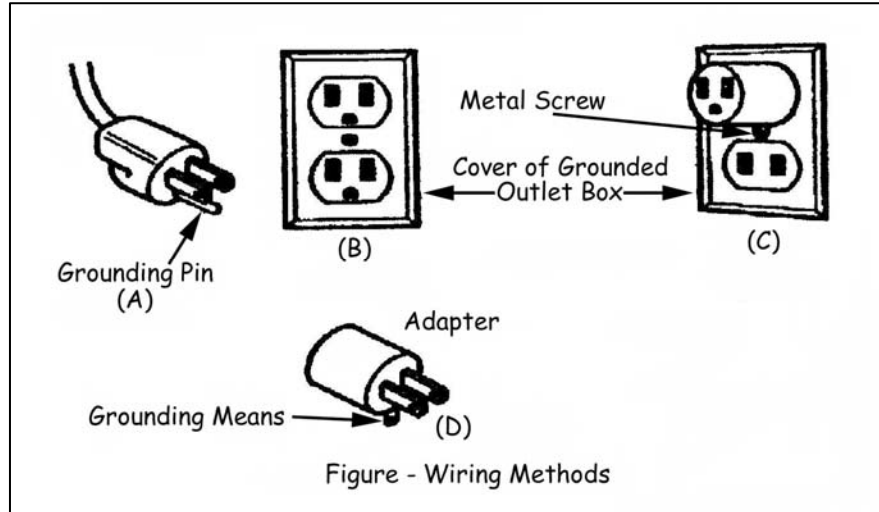

Fig. 1

1. Tools/equipment with three wire grounding plugs (Fig. 1, A) are intended for use on a circuit that has an outlet that looks like the one illustrated (Fig. 1, B).
2. A temporary adapter (Fig. 1, B & C) may be used to connect this plug to a 2-pole receptacle (Fig. 1, B) if a properly grounded outlet is not available.
3. The temporary adapter should be used only until a properly grounded outlet can be installed by a qualified electrician.
4. The green colored rigid ear, lug, etc. extending from the adapter must be connected to a permanent ground such as a properly grounded outlet box (Fig. 1, D).

Extension Cord Guidelines

Make sure your extension cord is in good condition. When using an extension cord, be sure to use one heavy enough to carry the current your product will draw. An undersized cord will cause a drop in line voltage resulting in loss of power and overheating. The table below shows the correct size to be used according to cord length and nameplate ampere rating. If in doubt, use the next heavier gauge. The smaller the gauge number, the heavier the cord.

Minimum Gauge for Extension Cords (AWG)
(When using 120 V only)

Ampere Rating		Total Length of Cord in feet			
More Than	Not More Than	25	50	100	150
0	6	18	16	16	14
6	10	18	16	14	12
10	12	16	16	14	12
12	16	14	12	Not Recommended	

1. Be sure your extension cord is properly wired and in good condition. Always replace a damaged extension cord or have it repaired by a qualified person before using it.
2. Protect your extension cords from sharp objects, excessive heat and damp or wet areas.
3. Use a separate electrical circuit for your tools/equipment. This circuit must not be less than a #12 wire and should be protected with a 20 Amp time-delayed fuse.
4. Before connecting the motor to the power line, make sure the switch is in the OFF position and the electric current is rated the same as the current stamped on the motor nameplate. Running at a lower voltage will damage the motor.

COMPONENTS

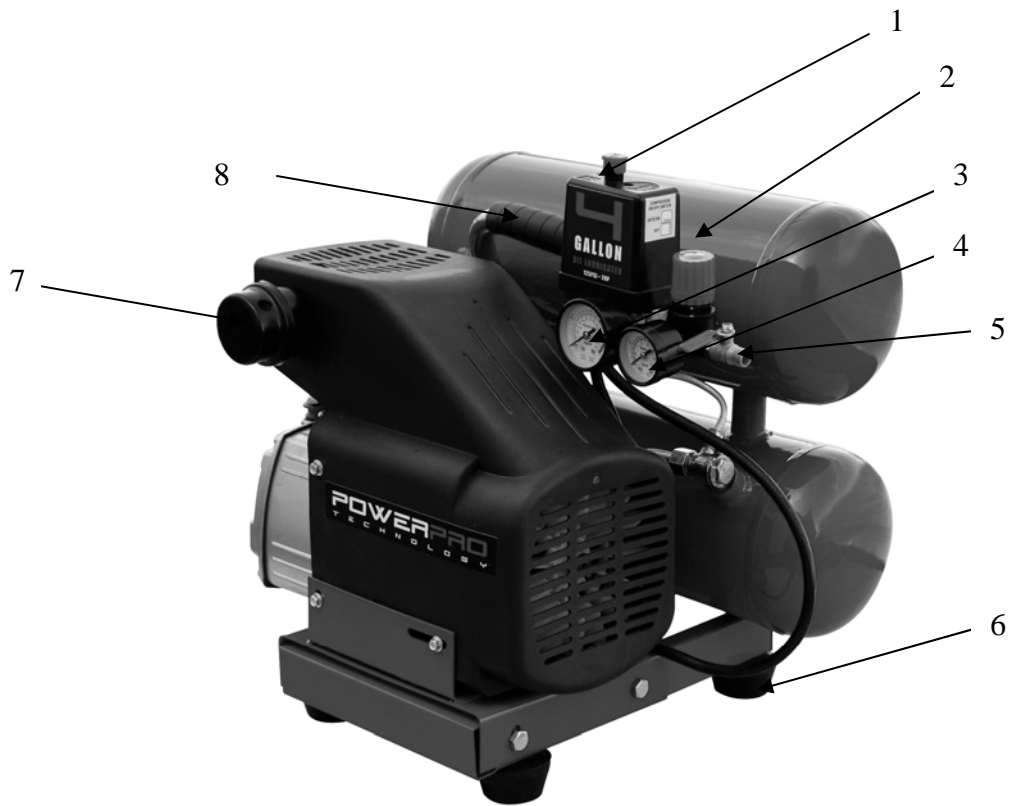

1 – ON/OFF Switch
3 – Tank Pressure Gauge
5 – Air Flow Valve
7 – Air Filter

2 – Air Regulator
4 – Air Regulator Gauge
6 – Rubber Foot
8 – Carrying Handle

ASSEMBLY INSTRUCTIONS

Unpacking

1. When unpacking, make sure that the machine is intact and undamaged.
2. Please check that the following items are included with your Air Compressor.
 - Oil Bottle
 - Air Filter
 - Oil Breather Cap
3. If any parts are missing or broken, please call our customer services at 1-800-232-1195.
4. Your Air Compressor requires minimum assembly. Remove the parts from the carton.

Air Filter Installation (Fig. 3)

This Air Compressor is shipped with a plastic plug in the air filter hole. Before operating this unit, remove the plug and connect the air filter (Fig 3).



Fig.3

Add Oil and Install Oil Breather Cap (Fig. 4 & 5)

1. Your Air Compressor ships without oil in the Crankcase.

Note: BEFORE STARTING YOU AIR COMPRESSOR YOU MUST ADD OIL TO THE CRANKCASE AS DESCRIBED BELOW.

2. Place your Air Compressor on level ground.
3. Remove the Oil Shipping Plug from the Oil Fill Hole located on the top of the Crankcase cover at the rear of the Air Compressor (Fig. 4).
4. Slowly pour the oil into the Oil Fill Hole until the oil level rises to the center of the red dot on the Oil Sight Glass (Fig. 5).
5. Install the Oil Breather Cap into the Oil Fill Hole.



Fig. 4

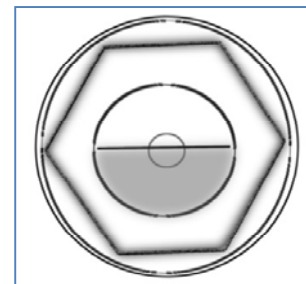

Fig. 5

OPERATION

BEFORE OPERATING YOUR NEW AIR COMPRESSOR complete the following steps.

1. Check that all nuts and bolts are secure.
2. Make sure the oil has been properly added to your Air Compressor.
3. Place your Air Compressor on a firm, level surface in a clean, dry, well ventilated area.
4. Your Air Compressor should be located 12 to 18 inches from walls or any other obstruction which would interfere with airflow. Your Air Compressor should be located in a temperature controlled area between 32°F and 95°F.
5. Do not place rags, containers or other material on top of your Air Compressor.

Power Source Connection

Your Air Compressor is designed to operate on a properly grounded 120 volt, 60HZ, single phase, alternating current (AC) power source with a fused 20 Amp time delayed fuse or circuit breaker. It is recommended that a qualified electrician verify the ACTUAL VOLTAGE at the receptacle into which the unit will be plugged and confirm that the receptacle is properly fused and grounded. The use of the proper circuit size can eliminate nuisance circuit breaker tripping while operating your Air Compressor. For electrical details see pages 7–9.

Initial Start-Up Procedures

1. Open the Air Tank Drain Valve to permit air to escape, preventing air pressure buildup in the Air Tank.
2. Run the compressor for a minimum of 20 minutes in this “no-load” position to lubricate the piston.
3. Close Air Tank Drain Valve. Your compressor is ready for use.
4. See pneumatic tool/equipment instructions for instructions on how to connect the tool/equipment to your Air Compressor.

Depending on the CFM draw of the tool/equipment being operated, your new Air Compressor can be used for operating paint sprayers, air tools/equipment, grease guns, airbrushes, caulking guns, abrasive blasters, tire & plastic toy inflation, spraying weed killer and insecticides, etc. Proper adjustment of the Air Pressure Regulator is necessary for all of these operations. Refer to the air pressure specifications provided with the tool/equipment you are using.

General Overview

1. To compress air, the piston moves up and down in the cylinder. On the down stroke air is drawn in through the valve inlet. The discharge valve remains closed. On the upstroke of the piston air is compressed.
2. The inlet valve closes and air is forced out through the discharge valve, through the Check Valve, and into the Air Tank.
3. Working air is not available until the compressor has raised the tank pressure above that required at the air service connection.
4. The air inlet filter openings must be kept clear of obstructions, which could reduce air delivery of the compressor.

Air Pressure Adjustment

1. Your Air Compressor is supplied with an Air Pressure Regulator. This Regulator adjusts the air pressure.
2. To increase air pressure, turn the Air Regulator clockwise.
3. To decrease air pressure, turn the Air Regulator counterclockwise.
4. The Air Regulator gauge will show the current pressure selected.

MAINTENANCE

Daily (or before each use)

1. Check oil level.
2. Check for any unusual noise or vibration.
3. Be sure all nuts and bolts are tight.

Weekly

1. Clean breather hole on Oil Breather Cap.
2. Drain water from the Air Tank through the Drain Valve.
3. Keep Air Filter clean at all times. Do not operate your Air Compressor with the air filter removed.
4. A dirty Air Filter will not allow your Air Compressor to operate at full capacity. Before you use your Air Compressor, check the Air Filter to be sure it is clean. If it is dirty replace the filter element.

Monthly

Inspect the air system for leaks by applying soapy water to all joints. Tighten these joints if leaks are discovered.

6 Months (or after 250 hours of operation - whichever comes first)

Change Air Compressor Oil.

Note: Change the oil more often if your Air Compressor is used near paint spraying operations or in dusty environments.

Checking the Air Compressor Oil

1. Place your Air Compressor on a level surface. The oil level should be at the red dot on the Oil Sight Glass.
2. If oil level is low, remove Oil Breather Cap and add enough oil to bring the oil level to the red dot on the Oil Sight Glass.

Changing the Air Compressor Oil

Note: This compressor uses only SAE 5W-30 motor oil.

1. Remove the Oil Sight Glass by turning counterclockwise with wrench.

Note: Oil will begin to drain as the Oil Sight Glass is loosened. Make sure a funnel and oil pan are in place BEFORE loosening the Oil Sight Glass.

2. Once the Oil Sight Glass is removed, tilt your Air Compressor forwards to allow all the oil to drain out of the Crankcase.
3. Once the oil is drained, replace the Oil Sight Glass and securely tighten in place with a wrench. Be careful not to over tighten the Oil Sight Glass, as this could damage the rubber seal.
4. Place your Air Compressor on level surface.
5. Remove the Oil Breather Cap.
6. Slowly pour the oil into the oil fill hole, until the oil level rises to the center of the red dot on the Oil Sight Glass.
7. Install the Oil Breather Cap into the oil fill hole.
8. Always inspect Air Compressor before use, and make sure it is in good working condition. Use compressed air to clean the machine where possible.
9. Check the power cable to make sure it is intact and free from cracks, bare wires etc.

10. Avoid using solvents when cleaning plastic parts, most plastics are susceptible to damage from the various types of commercial solvents.

TROUBLESHOOTING

Problem	Cause	Solution
Air compressor will not start.	Thermal overload.	Allow to cool and push the reset button located in the crankcase close to the air filter.
	Blown fuse or circuit breaker tripped.	Replace or reset fuse/circuit breaker.
	Loose electrical connections.	Check wiring connections.
Low pressure	Restricted air filter.	Replace air filter.
	Defective check valve.	Replace check valve.
	Air leak in safety valve.	Check valve by pulling on ring. If condition persists, replace valve.
Safety valve releasing.	Defective pressure switch.	Replace pressure switch.
Oil discharge in air compressor.	Too much oil in crankcase.	Drain crankcase and refill to proper level on oil sight glass.
	Air compressor overheated.	Reduce air pressure regulation.
	Restricted oil breather cap.	Clean or replace oil breather cap.

If trouble persists please call our customer service 1-800-232-1195, M-F 8-5 CST.

SERVICE

1. Mechanical and/or electrical tool/equipment service is to be performed only by professional qualified repair personnel. Service performed by unqualified personnel may result in a risk of injury.
2. When servicing a tool/equipment, use only identical replacement parts. Use of unauthorized parts or failure to follow maintenance instructions may create a risk of electrical shock or injury.

NOTE: If any parts are damaged or missing, do not attempt to plug in the power cord and turn the switch on until the damaged or missing parts are obtained and are installed correctly.

EXPLODED VIEW

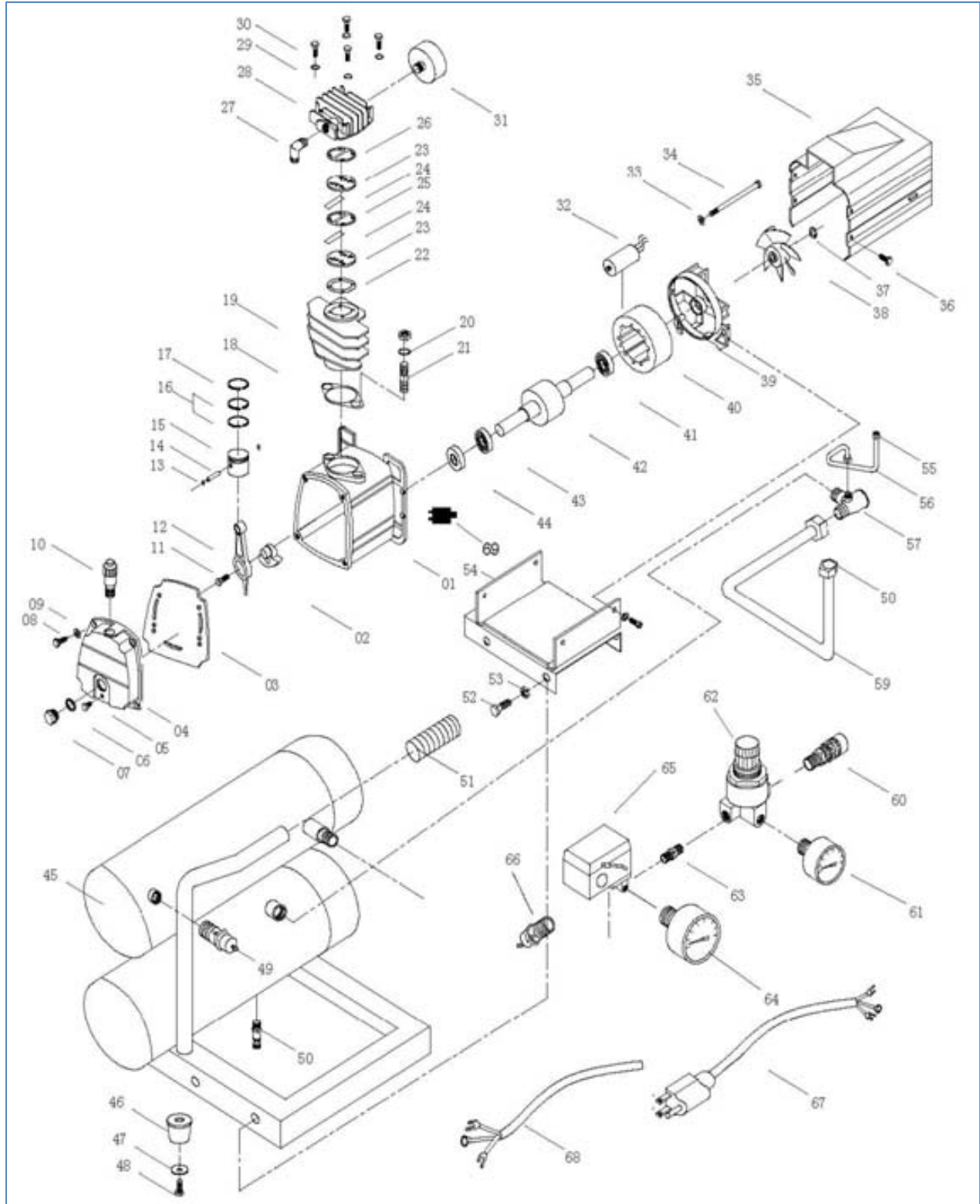

PARTS LIST

Part #	Stock #	Description
1	22040-001	Crankcase
2	22040-002	Crank Shaft
3	22040-003	Gasket
4	22040-004	Crankcase Cover
5	22040-005	Bolt
6	22040-006	O-ring
7	22040-007	Oil Sight Glass
8	22040-008	Bolt
9	22040-009	Washer
10	22040-010	Oil Breather Cap
11	22040-011	Bolt
12	22040-012	Connecting Rod
13	22040-013	Circle Clip
14	22040-014	Piston Pin
15	22040-015	Piston
16	22040-016	Piston Oil Ring
17	22040-017	Piston Ring
18	22040-018	Gasket
19	22040-019	Cylinder
20	22040-020	Washer
21	22040-021	Bolt
22	22040-022	Valve Gasket
23	22040-023	Valve
24	22040-024	Valve Plate
25	22040-025	Gasket
26	22040-026	Cylinder Head Gasket
27	22040-027	Elbow Connector
28	22040-028	Cylinder Head
29	22040-029	Washer
30	22040-030	Bolt
31	22040-031	Air Filter
32	22040-032	Capacitor
33	22040-033	Washer
34	22040-034	Bolt
35	22040-035	Motor Cover

Part #	Stock #	Description
36	22040-036	Bolt
37	22040-037	Circle Clip
38	22040-038	Fan
39	22040-039	Motor Back Cover
40	22040-040	Stator
41	22040-041	Bearing
42	22040-042	Rotor
43	22040-043	Bearing
44	22040-044	Oil Seal
45	22040-045	Air Tank Assembly
46	22040-046	Rubber Foot
47	22040-047	Washer
48	22040-048	Bolt
49	22040-049	Safety Valve
50	22040-050	Drain Valve
51	22040-051	Handle Grip
52	22040-052	Bolt
53	22040-053	Nut
54	22040-054	Base
55	22040-055	Unloading Nut
56	22040-056	Unloading Pipe
57	22040-057	Check Valve
58	22040-058	Exhaust Pipe Nut
59	22040-059	Exhaust Pipe
60	22040-060	Air flow Valve
61	22040-061	Air Regulator Gauge
62	22040-062	Regulator
63	22040-063	Connector
64	22040-064	Tank Pressure Gauge
65	22040-065	Pressure Switch
66	22040-066	Safety Valve
67	22040-067	Power Cord
68	22040-068	Wire Cable
69	22040-069	Overload Reset

ONE (1) YEAR LIMITED WARRANTY

Remember to save your receipt and to accurately fill out and mail your product registration card. You must provide proof of purchase for all warranty work.

POWER PRO products are warranted to be free from defects in materials and workmanship for a period of one (1) year from date of original purchase. Products used for Commercial or Rental use have a warranty period of 90 days from date of original purchase. Keep purchase receipt and mail in the product registration card for proof of purchase.

POWER PRO will repair or replace, at its discretion, any part that is proven to be defective in materials or workmanship under normal use during the one (1) year warranty period. Warranty repairs or replacements will be made without charge for parts or labor. Parts replaced during warranty repairs will be considered as part of the original product and will have the same warranty period as the original product.

To exercise the warranty, **DO NOT RETURN TO RETAILER**. Instead, call the toll free Customer Service number: **(800) 232-1195** and you will be instructed on where to take the products for warranty service. Take the products and proof of purchase (your receipt) to the repair facility recommended by the Customer Service Representative.

All transportation costs under warranty, including return to the factory if necessary, are to be borne by the purchaser and prepaid by the purchaser. The term “purchaser” means the person for whom the product is originally purchased. This warranty is non-transferable. The warranty does not extend to products damaged or affected by fuel contamination, accidents, neglect, misuse, unauthorized alterations, use in an application for which the product was not designed and any other modifications or abuse.

POWER PRO is not liable for any indirect, incidental or consequential damages from the sale or use of this product. Any implied warranties are limited to one (1) year as stated in this written limited warranty. Some states do not allow the exclusion or limitation of incidental or consequential damages. Some states do not allow limitation on the length of an implied warranty. This warranty gives you specific legal rights, and you may have other rights that vary from state to state.

