

OPERATOR'S MANUAL

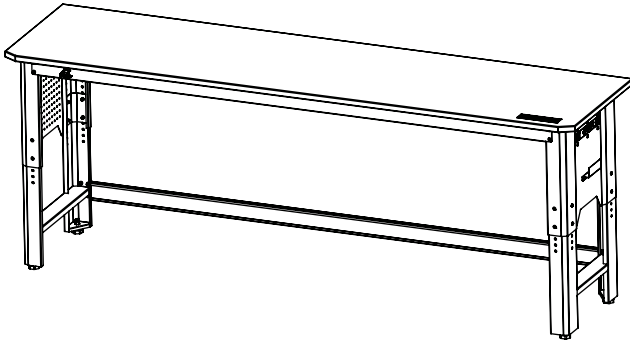

96 INCH WOOD TABLE WORKBENCH

Models
76635 - Butcher Block



UNPACKING INSTRUCTIONS

1. After opening shipping box, remove protective cardboard from top of wood table and place cardboard on floor.
2. With the aid of an assistant, remove wood table and lay topside down on cardboard to protect wood from scratching.
NOTE: Before laying down, determine the front side of the table. Front side has the Craftsman logo engraved into the right corner.
3. Remove the remainder of workbench parts from shipping box. Check parts and hardware against the PARTS and HARDWARE lists on the next page. If parts or hardware are missing return workbench to place of purchase for exchange.

* Product you purchased may vary from picture shown

REPLACEMENT PARTS

CALL 1-888-331-4569 FOR SERVICE PARTS. Refer to Parts section of this manual for drawing and listing of Workbench parts.

LOCATING MODEL # INFORMATION

Model numbers and other information required for service parts is located on a label on the inner side of the leg panel.

CAPACITIES

- Weight of bench: 135.7 lbs.
- The maximum combined weight of bench and loaded table must not exceed 1500 lbs.

MAINTENANCE

- Periodically the surfaces should be cleaned with a mild detergent and water.
- Grease and oil can be removed with most standard cleaning fluids. For safety, use a nonflammable cleaning fluid.
- Auto wax will preserve the luster finish of the workbench metal parts. Apply the wax as to a car. The wax will also help protect the metal parts against scratches.

SAFETY

⚠ WARNING indicates a hazardous situation which, if not avoided, could result in serious injury or death.

CAUTION is used to indicate a hazardous situation which, if not avoided, may result in minor injury, moderate injury, or property damage.

CAUTION: Read and follow all Safety Rules and Operating Instructions before first use of this product.

⚠ WARNING

- Use appropriate safety equipment when using power and hand tools. Failure to do so may cause personal injury or product damage.
- Obtain the aid of an assistant to assemble and move this unit. Failure to do so may cause personal injury or product damage.
- **DO NOT** alter this product in any manner. This may cause personal injury or product damage.
- Unit must be located on a level surface. The product may become unstable and tip if stored or moved on an un-level surface, which may cause personal injury or product damage.
- **DO NOT** stand on this product. You may fall or cause product to tip.
- **DO NOT** mount this product on a truck bed or any other moving object. This may cause personal injury or product damage.
- Appropriately secure this product before moving with a forklift.
- **DO NOT** tow with power equipment. The product may tip, which may cause personal injury or product damage.

WARRANTY

CRAFTSMAN LIMITED WARRANTY

FOR ONE YEAR from the date of sale this product is warranted against defects in material or workmanship. WITH PROOF OF SALE a defective product will be replaced free of charge.

For warranty coverage details to obtain free replacement, visit the web page: www.craftsman.com/warranty

This warranty is void if this product is ever used while providing commercial services or if rented to another person.

This warranty gives you specific legal rights, and you may also have other rights which vary from state to state.

Sears Brands Management Corporation, Hoffman Estates, IL 60179



NOTE: This device complies with Part 15 of the FCC Rules. Operation is subject to the following two conditions: (1) this device may not cause harmful interference, and (2) this device must accept any interference received, including interference that may cause undesired operation.



NOTE: This equipment has been tested and found to comply with the limits for a Class B digital device, pursuant to Part 15 of the FCC Rules. These limits are designed to provide reasonable protection against harmful interference in a residential installation. This equipment generates, uses and can radiate radio frequency energy and, if not installed and used in accordance with the instructions, may cause harmful interference to radio communications. However, there is no guarantee that interference will not occur in a particular installation.

If this equipment does cause harmful interference to radio or television reception, which can be determined by turning the equipment off and on, the user is encouraged to try to correct the interference by one or more of the following measures:

- Reorient or relocate the receiving antenna.
- Increase the separation between the equipment and receiver.
- Connect the equipment into an outlet on a circuit different from that to which the receiver is connected.
- Consult the dealer or an experienced radio/TV technician for help.

HARDWARE

TOOLS REQUIRED:

Phillips Head Screwdriver

HARDWARE INCLUDED:



M4x12 Screw (Qty: 2)



M6x12 Screw (Qty: 56)
NOTE: 16 of these screws are preattached to the Leg Panels.

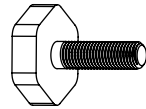

Screw Leveler (Qty: 4)
NOTE: Levelers are preassembled to Leg Panels.

PARTS

- A. Workbench Wood Table
- B. Crossbar
- C. Left Leg Panel
- D. Right Leg Panel
- E. Back Rail
- F. Power Strip
- G. Power Strip Cover
- H. Cord Holder
- I. Bottle Opener

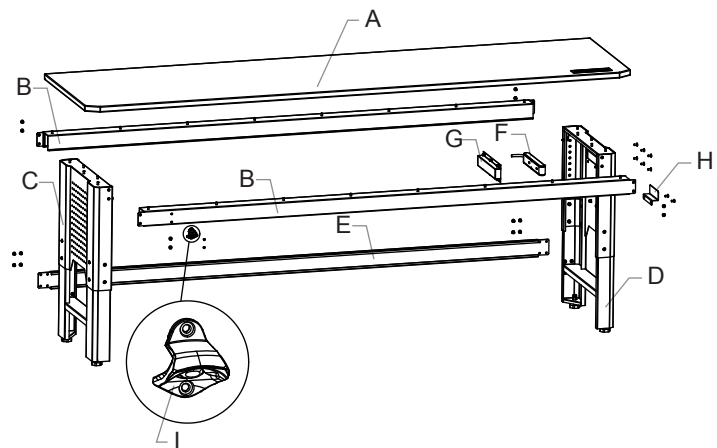

ASSEMBLY

1

Items Needed:

- Workbench Wood Table (Qty: 1)
- Left Leg Panel (Qty: 1)
- Right Leg Panel (Qty: 1)
- M6x12 Screw (Qty: 10)

- Determine the front and back of table. Front has Craftsman logo engraved in right corner. Leg Panels must be attached to table with Back Rail attachment holes to the back of table.
- If not already done, place the table topside down onto protective cardboard piece.

Table Front - Craftsman Logo Engraved on Top Side Right Corner

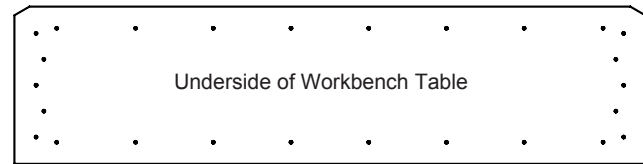
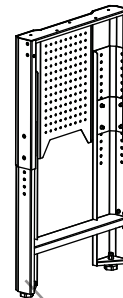
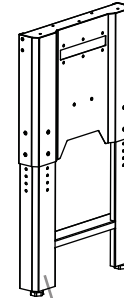

Table Back



Left Leg Panel
(has Pegboard Holes)



Right Leg Panel
(has Power Strip Opening)

2

Attach the Left and Right Leg Panels (C, D) to the underside of the Workbench Table:

- Align the pre-drilled holes in Table with holes in top of Legs.
- Partially tighten (5) M6x12 screws through each Leg into Table as shown in the figure below. Tighten screws so that Legs do not fall, but can be shifted for Crossbar attachment.

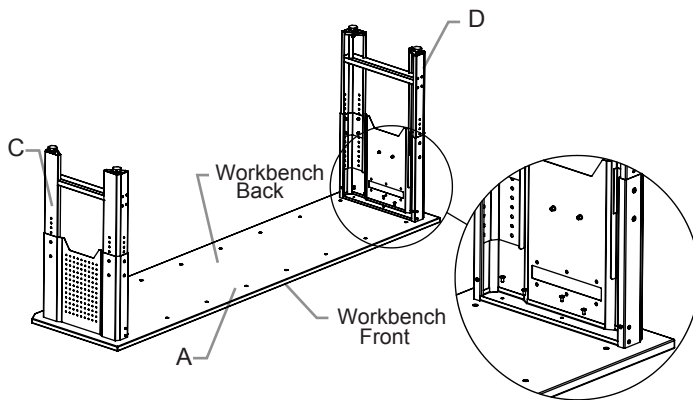

3

Items Needed:

- Crossbar (Qty: 2)
- M6x12 Screw (Qty: 28)

Attach Crossbars (B) to Front and Back of Table and to Left and Right Leg Panels:

- Align the pre-drilled holes in Table with holes in Crossbar length.
- Partially tighten (8) M6x12 screws through each Crossbar length into Table.
- Align Crossbar end holes with holes in Left and Right Legs.
- On each end of Crossbar, partially tighten (3) M6x12 screws through Crossbar holes into Leg holes as shown in figure below.

Note: The Crossbar end flanges must be attached so that they are on the outside of the Leg Panels.

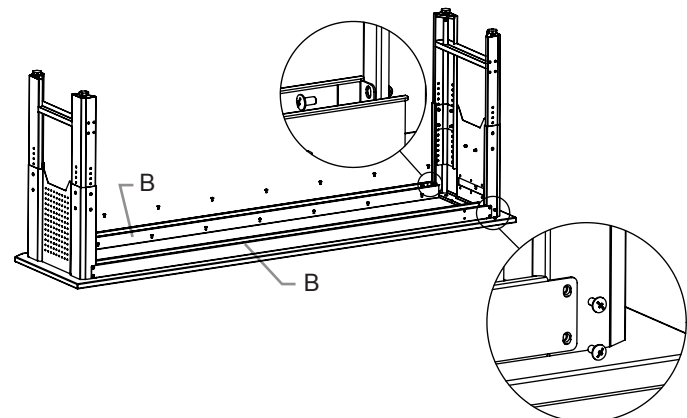

4

Items Needed:

Back Rail
M6x12 Screw (Qty: 8)

IMPORTANT: Before attaching Back Rail, adjust height of Leg Panels to the planned Workbench location. See Workbench Height Adjustment section on next page.

Attach Back Rail (E) to back of Left and Right Leg Panels:

- Align Back Rail end holes with holes in back of Left and Right Legs.
- Tighten (4) M6x12 screws through Back Rail end holes into Leg holes as shown in figure below.

Note: The Back Rail end flanges must be attached so that they are on the outside of the Leg Panels.

- Once the Back Rail is attached, go back and fully tighten all screws that were partially tightened up to this point in the assembly process.

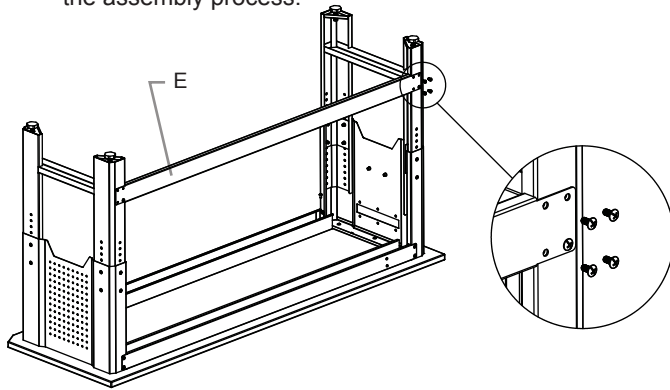

5

Items Needed:

Power Strip
Power Strip Cover
M6x12 Screw (Qty: 6)

- Insert the Power Strip (F) into the Power Strip Cover (G).
- Align the Power Strip Cover holes with the perimeter holes of the opening for the Power Strip on the inside of the Right Leg Panel.
- Tighten (6) M6x12 screws through Power Strip Cover holes into Leg Panel holes as shown in the figure below.

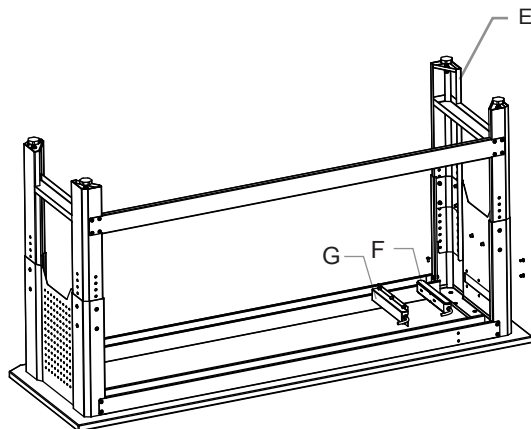

Note:

- The power strip has receptacle holes for four 3-pronged plugs. It also has two USB ports for charging electronic devices.
- Once power strip is plugged in, push toggle switch to RESET position for power strip operation.

6

Items Needed:

Cord Holder
M6x12 Screw (Qty: 2)

- With the aid of an assistant, set the the workbench in upright position.
- Align the holes in Cord Holder with Cord Holder attachment holes on outside of Right Leg Panel.
- Tighten (2) M6x12 screws through Cord Holder holes into Right Leg Panel holes as shown in figure below.

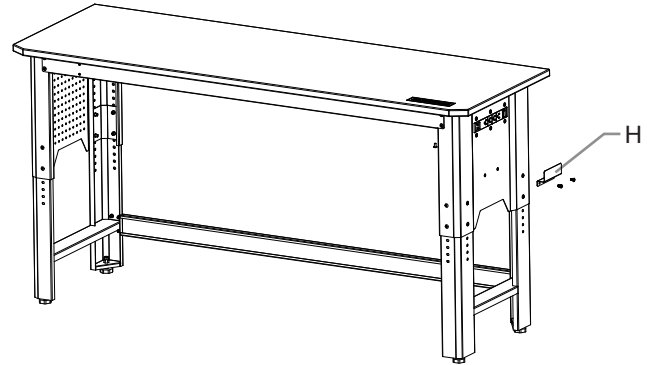

7

Items Needed:

Bottle Opener (Qty:1)
M4x12 Screw (Qty: 2)

- Align the holes in Bottle Opener with Bottle Opener attachment holes on left side of Crossbar.
- Tighten (2) M4x12 screws through Bottle Opener holes into Crossbar holes as shown in figure below.

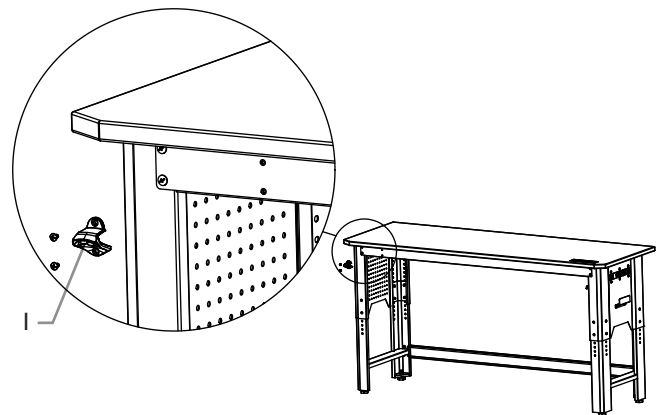

Note: The Left Leg Panel has pegboard holes through which hooks can be attached for hanging hand tools, work lights and similar items.

OPERATION

Leveling Foot Adjustment

- Adjust leveling position by turning the foot nut left to raise and right to lower the foot.

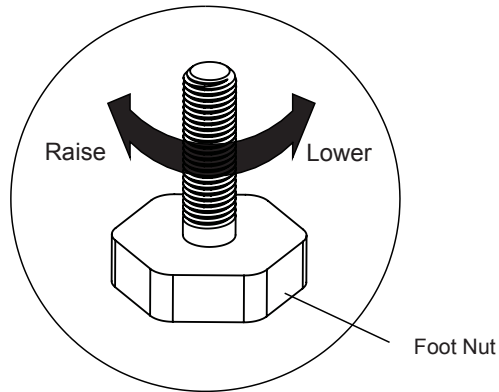

Workbench Height Adjustment

The Leg Panels are preset for a total workbench height of 36 inches (not including leveling feet). The Panels can be adjusted to alter the workbench height from 31 inches to 43 inches.

- Completely unscrew the (8) M6x12 Screws from each Leg Panel as shown in figure below.
- Raise or lower the leg bottoms to the same position in the leg channels on each Leg Panel.
- Insert and securely tighten the previously removed screws.

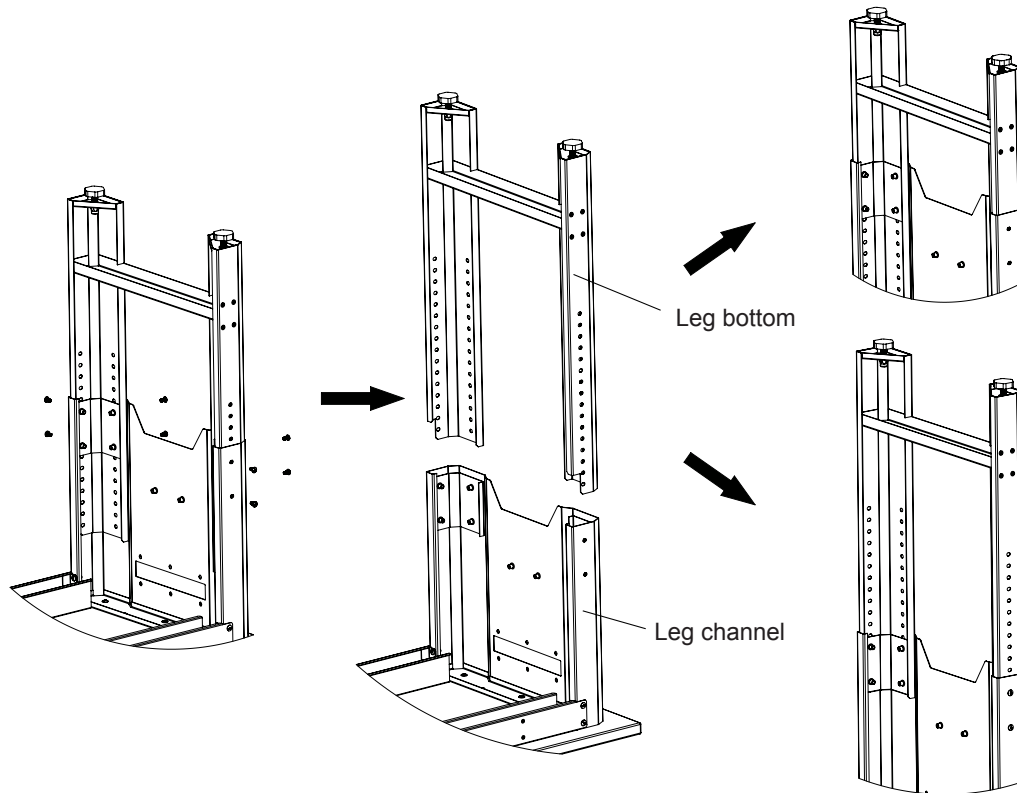

CRAFTSMAN®

Product questions or problems?

1-888-331-4569

Customer Care Hot Line

**Get answers to questions, troubleshoot problems,
order parts, or schedule repair service.**

Para respuestas a preguntas o problemas, y ordenar piezas o pedir
servicio para la reparación de su equipo.

To help us help you, register your product at www.craftsman.com/registration

Para poderte ayudar mejor, registra tu producto en www.craftsman.com/registration

Join the Craftsman Club today!

CRAFTSMAN CLUB®

www.craftsman.com/signup

Receive exclusive member benefits including special pricing and offers, project sharing, expert advice, and SHOP YOUR WAY REWARDS!

Como miembro exclusivo, recibe diversos beneficios como ofertas, precios especiales, proyectos nuevos, consejos de expertos y nuestro programa de puntos SHOP YOUR WAY REWARDS!

® Registered Trademark / TM Trademark of KCD IP, LLC in the United States, or Sears Brands, LLC in other countries
® Marca Registrada / TM Marca de Fábrica de KCD IP, LLC en Estados Unidos, o Sears Brands, LLC in otros países