

model no. TB-7208X

Excel®

72" 8 DRAWER TOOL CHEST

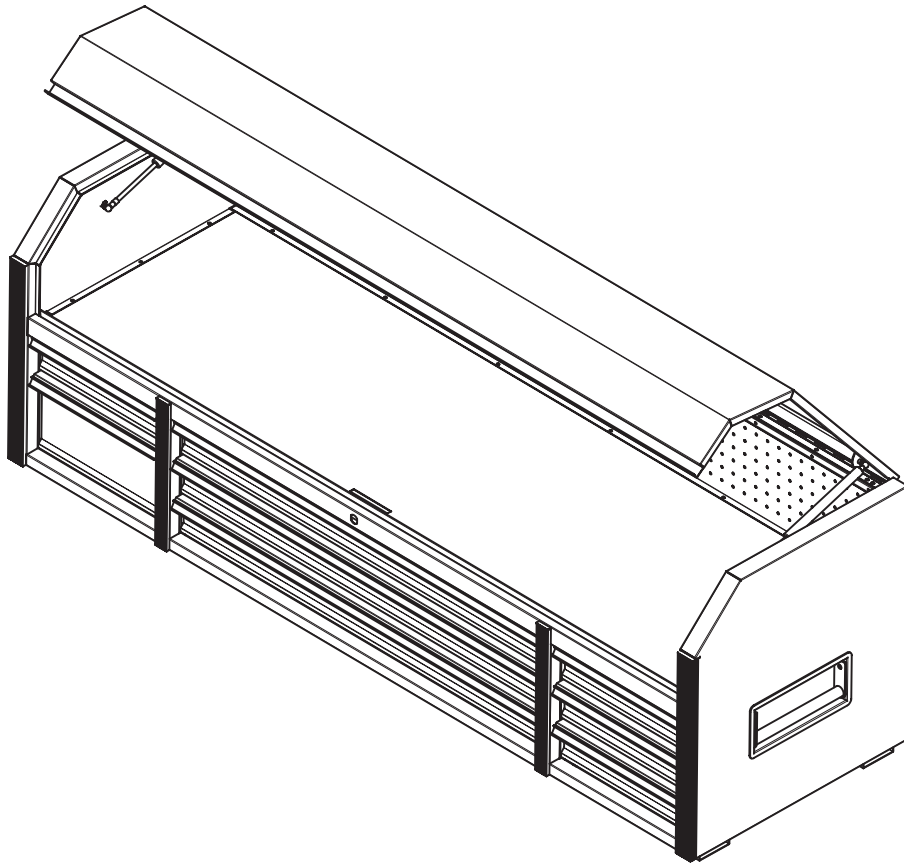

CAUTION: To reduce the risk of electric shock, please use the power strip only indoors. Do not use it in moist areas and do not plug it into another relocatable power strip.

IMPORTANT:

Please read this manual carefully and save it for reference.

**INSTRUCTION
MANUAL**

Read and follow all instructions before using this product

INSPECT this product before use. Do not use the product if you notice loose or damage parts.

LOAD the chest from the bottom up. Failure to load the chest from the bottom up may cause the product to tip, which could cause personal injury and product damage.

DO NOT open more than one drawer at one time. Opening more than one drawer at one time may cause the product to become unstable and tip, which may cause personal injury and product damage.

AVOID placing heavy loads into the chest at one time. Placing heavy loads in the chest at one time may cause the chest to tip and cause injury or product damage. Be careful of dynamic loading, dropping, or bouncing a load. This could temporarily create an excess load and cause product failure.

DO NOT stand on this product. Standing on the product may cause you to fall and cause personal injury.

DO NOT attempt to lift this product by the side handles using chains, ropes, or other lifting devices. The side handles could fail, which may cause personal injury or damage to the product.

DO NOT mount this product on a truck bed or other moving object. Mounting this product on a truck bed or other moving object may cause personal injury or product damage.

DO NOT alter this product in any manner. For example, do not weld external lock bars, or attach electrical equipment to the product. Altering this product may cause personal injury or product damage.

KEEP this product on level surfaces at all times. Failure to keep this product on level surfaces may cause it to become unstable and tip, which may cause personal injury and product damage.

CLOSE and lock the drawers before moving this product. The drawers could come open during movement and make the chest unstable and tip. Moving the chest with unlocked drawers may cause personal injury and property damage.

SPREAD the weight evenly in the drawers. The contents of the drawers could shift and fall out if the weight is not spread evenly. Failure to spread the weight evenly in the drawers may cause personal injury, damage the contents of the drawers, and cause damage to the chest.

DO NOT allow children to play on or around the chest. Failure to keep children from playing on or around the chest may cause personal injury or product damage.

THE MAXIMUM LOAD CAPACITY FOR THE TOP TRAY SHOULD BE NO MORE THAN 300 lb

THE MAXIMUM LOAD CAPACITY FOR THE TOP LEFT DRAWER SHOULD BE NO MORE THAN 80lb

THE MAXIMUM LOAD CAPACITY FOR THE BOTTOM LEFT DRAWER SHOULD BE NO MORE THAN 160 lb

THE MAXIMUM LOAD CAPACITY FOR THE MIDDLE THREE DRAWERS SHOULD BE NO MORE THAN 80 lb EACH

THE MAXIMUM LOAD CAPACITY FOR THE RIGHT THREE DRAWERS SHOULD BE NO MORE THAN 80 lb EACH

THE MAXIMUM LOAD CAPACITY FOR THE PRODUCT SHOULD BE NO MORE THAN 1020 lb