

OPERATOR'S MANUAL / MANUAL DEL USUARIO

DieHard®



**6V/12V Automatic
Battery Charger
& Engine Starter**

**6V / 12V Cargador
de baterías
automático
y arrancador**

**Model / Modelo:
28.71344**

CAUTION:

Read and follow all safety rules and operating instructions before every use of this product.

SAVE THESE INSTRUCTIONS.

ATENCIÓN:

Lea y siga todas las reglas de seguridad e instrucciones de uso antes de cada uso de este producto.

GUARDE ESTAS INSTRUCCIONES.

Sears Brands Management Corporation, Hoffman Estates, IL 60179 U.S.A.

0099001453-00

DIEHARD® THREE-YEAR FULL WARRANTY

When operated and maintained according to all supplied instructions, if this DieHard® product fails due to a defect in material or workmanship within 3 years from the date of purchase, return it to any DieHard® outlet in the United States for free replacement.

This warranty gives you specific legal rights, and you may also have other rights which vary from state to state.

Sears Brands Management Corporation, Hoffman Estates, IL 60179

**FOR CUSTOMER ASSISTANCE OR REPLACEMENT PARTS,
CALL 1-800-SEARS-64 (1-800-732-7764) TOLL-FREE
FROM 7 AM TO 5 PM CT.**

DIEHARD® TRES AÑOS DE GARANTÍA TOTAL

Cuando se opere o maneje con las debidas precauciones de acuerdo a las instrucciones, si el DieHard® falla en alguno de sus componentes de fabricación durante los 3 años contados a partir de la fecha de compra, regresarlo al autoservicio DieHard® en los estados unidos para reemplazar el aparato sin costo alguno.

Esta garantía le otorga derechos legales específicos, así como otros derechos, que varían de estado a estado.

Sears Brands Management Corporation, Hoffman Estates, IL 60179

**PARA ASISTENCIA AL CLIENTE O REPUESTOS,
LLAME GRATIS AL 7 AM-5 PM CT
LUNES A VIERNES: 1-800-SEARS-64 (1-800-732-7764)**

1. IMPORTANT SAFETY INSTRUCTIONS

SAVE THESE INSTRUCTIONS.

- 1.1 SAVE THESE INSTRUCTIONS –**
This manual contains important safety and operating instructions.
- 1.2** Do not expose the charger to rain or snow.
- 1.3** Use of an attachment not recommended or sold by the battery charger manufacturer may result in a risk of fire, electric shock or injury to persons.
- 1.4** To reduce the risk of damage to electric plug and cord, pull by the plug rather than the cord when disconnecting charger.
- 1.5** An extension cord should not be used unless absolutely necessary. Use of improper extension cord could result in a risk of fire and electric shock. If an extension cord must be used, make sure:
 - That the pins on plug of extension cord are the same number, size and shape as those of plug on charger.
 - That extension cord is properly wired and in good electrical condition; and
 - That wire size is large enough for AC ampere rating of charger as specified in the section 8.
- 1.6** Do not operate charger with damaged cord or plug – replace the cord or plug immediately.
- 1.7** Do not operate charger if it has received a sharp blow, been dropped, or otherwise damaged in any way; take it to a qualified serviceman.
- 1.8** Do not disassemble charger; take it to a qualified serviceman when service or repair is required. Incorrect reassembly may result in a risk of electric shock or fire.
- 1.9** To reduce risk of electric shock, unplug charger from outlet before attempting any maintenance or cleaning. Turning off controls will not reduce this risk.
- 1.10 WARNING: RISK OF EXPLOSIVE GASES.**
 - a. WORKING IN VICINITY OF A LEAD-ACID BATTERY IS DANGEROUS.**
BATTERIES GENERATE EXPLOSIVE GASES DURING NORMAL BATTERY OPERATION. FOR THIS REASON, IT IS OF UTMOST IMPORTANCE THAT YOU FOLLOW THE INSTRUCTIONS EACH TIME YOU USE THE CHARGER.
 - b.** To reduce risk of battery explosion, follow these instructions and those published by battery manufacturer and manufacturer of any equipment you intend to use in vicinity of battery. Review cautionary marking on these products and on engine.
- 1.11** Pursuant to California Proposition 65, this product contains chemicals known to the State of California to cause cancer and birth defects or other reproductive harm. Wash hands after handling.
- 1.12** Keep out of reach of children.

2. PERSONAL SAFETY PRECAUTIONS

- 2.1** Consider having someone close enough by to come to your aid when you work near a lead-acid battery.
- 2.2** Have plenty of fresh water and soap nearby in case battery acid contacts skin, clothing, or eyes.
- 2.3** Wear complete eye protection and clothing protection. Avoid touching eyes while working near battery.
- 2.4** If battery acid contacts skin or clothing, wash immediately with soap and water. If acid enters eye, immediately flood eye with running cold water for at least 10 minutes and get medical attention immediately.
- 2.5** NEVER smoke or allow a spark or flame in vicinity of battery or engine.
- 2.6** Be extra cautious to reduce risk of dropping a metal tool onto battery. It might spark or short-circuit battery or other electrical part that may cause explosion.
- 2.7** Remove personal metal items such as rings, bracelets, necklaces, and watches when working with a lead-acid battery. A lead-acid battery can produce a short-circuit current high enough to weld a ring or the like to metal, causing a severe burn.
- 2.8** Use charger for charging only 6 and 12V LEAD-ACID, AGM and GEL-type rechargeable batteries. It is not intended to supply power to a low voltage electrical system other than in a starter-motor application. Do not use battery charger for charging dry-cell batteries that are commonly used with home appliances. These batteries may burst and cause injury to persons and damage to property.
- 2.9** NEVER charge a frozen battery.

3. PREPARING TO CHARGE

- 3.1 If necessary to remove battery from vehicle to charge, always remove grounded terminal from battery first. Make sure all accessories in the vehicle are off, so as not to cause an arc.
- 3.2 Be sure area around battery is well ventilated while battery is being charged.
- 3.3 Clean battery terminals. Be careful to keep corrosion from coming in contact with eyes.
- 3.4 Add distilled water in each cell until battery acid reaches level specified by battery manufacturer. Do not overfill. For a battery without removable cell caps, such as valve regulated lead acid batteries, carefully follow manufacturer's recharging instructions.
- 3.5 Study all battery manufacturer's specific precautions while charging and recommended rates of charge.
- 3.6 Determine voltage of battery by referring to car owner's manual and make sure that output voltage selector switch is set at correct voltage. If charger has adjustable charge rate, charge battery initially at lowest rate.

4. CHARGER LOCATION

- 4.1 Locate charger as far away from battery as DC cables permit.
- 4.2 Never place charger directly above battery being charged; gases from battery will corrode and damage charger.
- 4.3 Never allow battery acid to drip on charger when reading electrolyte specific gravity or filling battery.
- 4.4 Do not operate charger in a closed-in area or restrict ventilation in any way.
- 4.5 Do not set a battery on top of charger.

5. DC CONNECTION PRECAUTIONS

- 5.1 Connect and disconnect DC output clips only after setting any charger switches to "off" position and removing AC cord from electric outlet. Never allow clips to touch each other.
- 5.2 Attach clips to battery and chassis, as indicated in the sections 6 and 7.

6. FOLLOW THESE STEPS WHEN BATTERY IS INSTALLED IN VEHICLE

A SPARK NEAR THE BATTERY MAY CAUSE A BATTERY EXPLOSION. TO REDUCE THE RISK OF A SPARK NEAR THE BATTERY:

- 6.1 Position AC and DC cords to reduce risk of damage by hood, door, or moving engine part.
- 6.2 Stay clear of fan blades, belts, pulleys, and other parts that can cause injury to persons.
- 6.3 Check polarity of battery posts. POSITIVE (POS, P, +) battery post usually has larger diameter than NEGATIVE (NEG, N, -) post.
- 6.4 Determine which post of battery is grounded (connected) to the chassis. If negative post is grounded to chassis (as in most vehicles), see (6.5). If positive post is grounded to the chassis, see (6.6).
- 6.5 For negative-grounded vehicle, connect POSITIVE (RED) clip from battery charger to POSITIVE (POS, P, +) ungrounded post of battery. Connect NEGATIVE (BLACK) clip to vehicle chassis or engine block away from battery. Do not connect clip to carburetor, fuel lines, or sheet-metal body parts. Connect to a heavy gage metal part of the frame or engine block.
- 6.6 For positive-grounded vehicle, connect NEGATIVE (BLACK) clip from battery charger to NEGATIVE (NEG, N, -) ungrounded post of battery. Connect POSITIVE (RED) clip to vehicle chassis or engine block away from battery. Do not connect clip to carburetor, fuel lines, or sheet-metal body parts. Connect to a heavy gage metal part of the frame or engine block.
- 6.7 When disconnecting charger, turn switches to off, disconnect AC cord, remove clip from vehicle chassis, and then remove clip from battery terminal.
- 6.8 See *Operating Instructions* for length of charge information.

7. FOLLOW THESE STEPS WHEN BATTERY IS OUTSIDE VEHICLE

A SPARK NEAR THE BATTERY MAY CAUSE A BATTERY EXPLOSION. TO REDUCE THE RISK OF A SPARK NEAR THE BATTERY:

- 7.1 Check polarity of battery posts. POSITIVE (POS, P, +) battery post usually has a larger diameter than NEGATIVE (NEG, N, -) post.
- 7.2 Attach at least a 24-inch-long 6-gauge (AWG) insulated battery cable to NEGATIVE (NEG, N, -) battery post.
- 7.3 Connect POSITIVE (RED) charger clip to POSITIVE (POS, P, +) post of battery.
- 7.4 Position yourself and free end of cable as far away from battery as possible – then

connect NEGATIVE (BLACK) charger clip to free end of cable.

- 7.5 Do not face battery when making final connection.
- 7.6 When disconnecting charger, always do so in reverse sequence of connecting procedure and break first connection while as far away from battery as practical.
- 7.7 A marine (boat) battery must be removed and charged on shore. To charge it on board requires equipment specially designed for marine use.

8. GROUNDING AND AC POWER CORD CONNECTIONS

This battery charger is for use on a nominal 120 volt circuit and has a grounded plug. The charger must be grounded, to reduce the risk of electric shock. The plug must be plugged into an outlet that is properly installed and grounded in accordance with all local codes and ordinances. The plug pins must fit the receptacle (outlet). Do not use with an ungrounded system.

DANGER: Never alter the AC cord or plug provided – if it does not fit the outlet, have a proper grounded outlet installed by a qualified electrician. An improper connection can result in a risk of an electric shock or electrocution.

NOTE: Pursuant to Canadian Regulations, use of an adapter plug is not allowed in Canada. Use of an adapter plug in the United States is not recommended and should not be used.

USING AN EXTENSION CORD

The use of an extension cord is not recommended. If you must use an extension cord, follow these guidelines:

- Pins on plug of extension cord must be the same number, size, and shape as those of plug on charger.
- Ensure that the extension cord is properly wired and in good electrical condition.
- Wire size must be large enough for the AC ampere rating of charger, as specified:

Length of cord (feet)	25	50	100	150
AWG* size of cord	10	10	10	8

*AWG-American Wire Gauge

9. ASSEMBLY INSTRUCTIONS

- 9.1 It is important to fully assemble your charger before use. Remove all cord wraps and uncoil the cables prior to using the battery charger. Follow these instructions for assembly.

Parts Included

- (2) #8 x 0.25" screws (A)
- (2) #10 x 1.0" screws (B)
- (1) handle

Tools Needed

Phillips-head screwdriver (not included)

- 9.2 **Attach the handle:** Place each end of handle into its bracket, aligning with the screw holes. Insert screws as shown. Plug the cable into the port, as shown (C).
IMPORTANT: Port is ONLY for plugging in the charger handle. It is not compatible with any other equipment.

CAUTION: Take care not to pinch or damage cable during handle installation. Charger will not function properly if this cable is damaged.

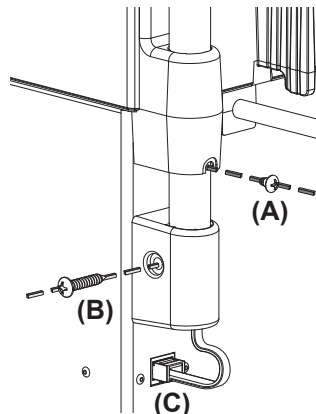

10. CONTROL PANEL

DIGITAL DISPLAY

The digital display indicates the status of the battery and charger. See the *Display Messages* section for a complete list of messages.

DISPLAY MODE BUTTON

Use this button to set the function of the digital display to one of the following:

- **Battery %** – The digital display shows an estimated charge percentage of the battery connected to the charger's battery clamps.
- **Alternator %** – The digital display shows an estimated output percentage of the vehicle's charging system connected to the charger's battery clamps, compared to a properly functioning system. The alternator percent range is from 0 to 100%. Readings below 0 (13.2 volts) will read **LOW** and readings above 100% (14.6 volts) will read **HIGH**. If you get a **HIGH** or **LOW** reading, have the electrical system checked by a qualified technician.
- **Voltage** – The Digital Display shows the voltage at the charger battery clamps, in DC volts.

RATE SELECTION BUTTON

Use this button to select one of the following:

- **2A CHARGE** – For charging small batteries, such as those commonly used in garden tractors, snowmobiles and motorcycles.
- **20A FAST or 60A RAPID CHARGE** – For charging automotive, marine and light truck batteries. Not intended for industrial applications.
- **ENGINE START** – Provides high amperage for cranking an engine with a weak or run-down battery. Always use in combination with a battery.

NOTE: Once the charger has started charging the battery, if you press the Rate Selection button once, the output current is shut off and the display will show **OFF** and then the battery voltage. If you press the Rate Selection button again, the current will go back on at the same setting it was when it was turned off.

LED INDICATORS

REVERSED (red) LED lit: The clamps are not properly connected to the battery.

CHARGING (yellow/orange) LED lit: The charger is charging the battery.

CHARGING (yellow/orange) LED

flashing: The charger is in abort mode.

CHARGED/MAINTAINING (green) LED

lit: The battery is fully charged and the charger is in maintain mode.

NOTE: See the Operating Instructions section for a complete description of the charger modes.

BATTERY TYPE BUTTON

Use this button to set the type of battery.

- **STANDARD** – Used in cars, trucks and motorcycles, these batteries have vent caps and are often marked "low maintenance" or "maintenance-free". This type of battery is designed to deliver quick bursts of energy (such as starting engines) and has a greater plate count. The plates are thinner and have somewhat different material composition. Standard batteries should not be used for deep-cycle applications.
 - **AGM** – The Absorbed Glass Mat construction allows the electrolyte to be suspended in close proximity with the plate's active material. In theory, this enhances both the discharge and recharge efficiency. The AGM batteries are a variant of Sealed VRLA (valve regulated lead-acid) batteries. Popular uses include high-performance engine starting, power sports, deep-cycle, solar and storage batteries.
 - **GEL** – The electrolyte in a GEL cell has a silica additive that causes it to set up or stiffen. The recharge voltages on this type of cell are lower than those for other styles of lead-acid battery. This is probably the most sensitive cell in terms of adverse reactions to overvoltage charging. Gel batteries are best used in VERY DEEP cycle application and may last a bit longer in hot weather applications. If the wrong battery charger is used on a gel cell battery, poor performance and premature failure will result.
 - **DIEHARD PLATINUM** – Select this option only if your battery is a DieHard Platinum battery. **NOTE:** When DieHard Platinum is selected, the recommended charge rate is 60A.
- ### TWO TOGGLE SWITCHES
- These are found on the base of the unit.
- **ON/OFF SWITCH**
 - **VOLTAGE SELECTOR SWITCH**
Select 6V or 12V.

11. OPERATING INSTRUCTIONS

WARNING: A spark near battery may cause an explosion.

IMPORTANT: Do not start the vehicle with the charger connected to the AC outlet, or it could damage the charger.

NOTE: This charger is equipped with an auto-start feature. Current will not be supplied to the battery clamps until a battery is properly connected. The clamps will not spark if touched together.

CHARGING A BATTERY IN THE VEHICLE

1. Turn off all the vehicle's accessories.
2. Keep the hood open.
3. Clean the battery terminals.
4. Place the charger on a dry, non-flammable surface.
5. Lay the AC/DC cables away from any fan blades, belts, pulleys and other moving parts.
6. Make sure the ON/OFF switch is set to OFF.
7. Connect the battery, following the precautions listed in sections 6 and 7.
8. Connect the charger to an electrical outlet.
9. Press the ON/OFF switch to turn ON.
10. When the charger starts, the display will show **DIEHARD**.
11. Select the battery type and charge rate. Charging will then begin automatically. See section 12 for **CHARGING** message details.
12. The yellow/orange LED will light, and the display will show **ANALYZING BATTERY** while the charger determines that the battery is properly connected and the condition of the battery.
13. When charging is complete, press the ON/OFF switch to turn OFF, disconnect the charger from the AC power, remove the clamps from the vehicle's chassis, and then remove the clamp from the battery terminal.

CHARGING A BATTERY OUTSIDE OF THE VEHICLE

1. Place battery in a well-ventilated area.
2. Clean the battery terminals.
3. Make sure the ON/OFF switch is set to OFF.
4. Connect the battery, following the precautions listed in sections 6 and 7.

5. Connect the charger to the electrical outlet.
6. Press the ON/OFF switch to turn ON.
7. When the charger starts, the display will show **DIEHARD**.
8. Select the battery type and charge rate. Charging will then begin automatically. See section 12 for **CHARGING** message details.
9. The yellow/orange LED will light, and the display will show **ANALYZING BATTERY** while the charger determines that the battery is properly connected and the condition of the battery.
10. When charging is complete press the ON/OFF switch to turn OFF, disconnect the charger from the AC power, disconnect the negative clamp, and finally the positive clamp.
11. A marine (boat) battery must be removed and charged on shore.

AUTOMATIC CHARGING MODE

When an Automatic Charge is performed, the charger switches to the maintain mode automatically after the battery is charged.

BATTERY CONNECTION INDICATOR

If the charger does not detect a properly connected battery, charging will not start and the digital display will show one of two messages. If the display shows **CONNECT CLAMPS**, make sure the charger is connected to the battery and the connection points are clean and making a good connection. If the display shows **WARNING CLAMPS REVERSED**, press the ON/OFF switch to turn off, unplug the charger from the AC outlet and then reverse the connections at the battery.

CHARGE COMPLETION AND MAINTAIN MODE (FLOAT MODE MONITORING)

Charge completion is indicated by the solid green LED and the digital display showing **FULLY CHARGED AUTO MAINTAINING**. This means that the charger has stopped charging and has switched to the Maintain Mode of operation. **NOTE:** If the charger has to provide its maximum maintain current for a continuous 12 hour period, it will go into Abort Mode (see Aborted Charge section). This is usually caused by a drain on the battery, or the battery could be bad. Make sure there are no loads on the battery. If there are, remove them. If there are none, have the battery checked or replaced.

BATTERY CHARGING TIMES

Use the following table to determine the time it will take to bring a battery to full charge.

Ah – Ampere Hours

CCA – Cold Cranking Amps

RC – Reserve Capacity

NR – NOT RECOMMENDED.

BATTERY SIZE/RATING			CHARGE RATE/CHARGING TIME		
			2 AMP	20 AMP	60 AMP
SMALL BATTERIES	Motorcycle, garden tractor, etc.	6-12 Ah	2-3¼ h	NR	NR
		12-32 Ah	3¼-10 h	NR	NR
CARS/ TRUCKS	200-315 CCA	40-60 RC	11¼-14½ h	1-1½ h	23-29 min
	315-550 CCA	60-85 RC	NR	1½-2 h	29-37 min
	550-1000 CCA	80-190 RC	NR	2-3½ h	37-70 min
MARINE/DEEP-CYCLE		80 RC	NR	1¾ h	NR
		140 RC	NR	2¾ h	NR
		160 RC	NR	3 h	NR
		180 RC	NR	3¼ h	NR

The times given are for batteries with a 50% charge prior to recharging.

MAINTAINING A BATTERY

The 28.71344 maintains 6 and 12 volt batteries, keeping them at full charge.

It is not recommended for industrial applications.

NOTE: The maintain mode technology allows you to safely charge and maintain a healthy battery for extended periods of time. However, problems with the battery, electrical problems in the vehicle, improper connections or other unanticipated conditions could cause excessive current draws. As such, occasionally monitoring your battery and the charging process is required.

DESULFATION MODE

If the battery is left discharged for an extended period of time, it could become sulfated and not accept a normal charge. If the charger detects a sulfated battery, the charger will switch to a special mode of operation designed for such batteries. If successful, normal charging will resume after the battery is desulfated. Desulfation could take up to 8 hours. If desulfation fails, charging will abort, the yellow/orange LED will flash, and the display will show **CHARGING ABORTED BAD BATTERY**.

ABORTED CHARGE

If charging cannot be completed normally, charging will abort. When charging aborts, the charger's output is shut off, the yellow/orange LED will flash, and the display will show **CHARGING ABORTED BAD BATTERY**. To reset after an aborted charge, unplug the charger from the outlet, wait a few moments and plug it back in.

USING THE ENGINE START SETTING

Your battery charger can be used to jump start your car if the battery is low. Follow all safety instructions and precautions for

charging your battery. **Wear complete eye protection and protective clothing.**

WARNING: Using the ENGINE START setting WITHOUT a battery installed in the vehicle could cause damage to the vehicle's electrical system.

NOTE: If you have charged the battery and it still will not start your car, do not use the Engine Start setting, or it could damage the vehicle's electrical system. Have the battery checked.

1. With the charger unplugged from the AC outlet, connect the charger to the battery, following the instructions given in sections 6 and 7.
2. With the charger plugged in and connected to the battery and chassis, press the ON/OFF switch to turn ON, and then press the RATE SELECTION button until the ENGINE START LED is lit.
3. When the display shows **ENGINE START READY**, crank the engine until it starts or 3 seconds pass. If the engine does not start, wait 3 minutes (until the display shows **ENGINE START READY**) before cranking again. This allows the charger and battery to cool down.

NOTE: During extremely cold weather, or if the battery is under 2 volts, charge the battery for 5 minutes before cranking the engine.

4. If the engine fails to start, charge the battery for 5 more minutes before attempting to crank the engine again.
5. After the engine starts, press the ON/OFF switch to turn OFF, unplug the AC power cord before disconnecting the battery clamps from the vehicle.

NOTE: If the engine does not turn over but never starts, there is not a problem with the starting system; there is a problem somewhere else with the vehicle. STOP cranking the engine until the other problem has been diagnosed and corrected.

ENGINE STARTING NOTES

During the starting sequence, the charger is set to one of three states:

- **Wait for cranking** – The charger waits until the engine is actually being cranked before delivering the amps for engine start and will reset if the engine is not cranked within 15 minutes. (If the charger resets, it sets itself to the default start up settings). While waiting for cranking, the digital display shows the battery charged percentage (it cannot be set to voltage). After 5 seconds, the display will change to **ENGINE START READY**.
- **Cranking** – When cranking is detected, the charger will automatically deliver up to its maximum output as required by the starting system for up to 5 seconds or until the engine cranking stops. The digital display shows a countdown of the remaining crank time.
- **Cool Down** – After cranking, the charger enters a mandatory 3 minute (180 second) cool down state. The digital display will show **ENGINE START COOL DOWN XXX SECONDS REMAINING**. It starts at 180 and counts down to 0. After 3 minutes, the digital display will change to **ENGINE START READY**. The CHARGING (yellow/orange) LED will then be lit.

USING THE BATTERY VOLTAGE TESTER

1. With the charger unplugged from the AC outlet, connect the charger to the battery, following the instructions given in previous sections.
2. Plug the charger's AC power cord into the AC outlet.
3. Press the ON/OFF switch to turn ON.
4. If necessary, press the BATTERY TYPE button until the correct type is indicated.
5. Read the voltage on the digital display. Keep in mind that this reading is only a battery voltage reading; a false surface charge may mislead you. Compare the reading to the following chart.

6V Battery Voltage Reading	12V Battery Voltage Reading	Battery Condition
6.4 or more	12.8 or more	Charged
6.1 to 6.3	12.2 to 12.7	Needs charging
Less than 6.1	Less than 12.2	Discharged

TESTER AND CHARGER

When first turned on, the unit operates only as a tester, not as a charger. Selecting a charge rate activates the battery charger and deactivates the tester. Pressing the RATE SELECTION button when the ENGINE START LED is lit (except during the 180 second cool down) will shut off the charger and activate the tester.

POWER-UP IDLE TIME LIMIT

If no button is pressed within 10 minutes after the battery charger is first powered up, the charger will automatically switch from tester to charger if a battery is connected. In that case, the charger will be set to charge at the 2A charge rate and Gel battery type.

TESTER WITHOUT TIME LIMIT

If either the DISPLAY MODE or BATTERY TYPE button is pressed within the first 10 minutes after the battery charger is powered up, the unit will remain a tester (not a charger) indefinitely, unless a charge rate is selected.

TESTING AFTER CHARGING

After the unit has been changed from tester to charger (by selecting a charge rate), it remains a charger. To change the battery charger back to a tester, press the RATE SELECTION button until all charge rate LEDs are off.

NOTE: The battery tester is only designed to test batteries. Testing a device with a rapidly changing voltage could yield unexpected or inaccurate results.

USING THE ALTERNATOR PERFORMANCE TESTER

1. With the charger unplugged from the AC outlet, connect the charger to the battery, following the instructions given in previous sections.
2. Plug the charger AC power cord into the AC outlet.
3. Press the ON/OFF switch to turn ON.
4. Start the vehicle and turn on the vehicle's headlights. Read the voltage on the digital display. If you get a reading between 13.2 volts and 14.6 volts, the alternator is working properly. If the reading is less than 13.2 volts or more than 14.6 volts, have the charging system checked by a qualified technician.

NOTE: Refer to your vehicle owner's manual for appropriate voltage numbers for your alternator.

FAN OPERATION

It is normal for the fan to start and stop when maintaining a fully charged battery. The fan does not run in Tester Mode. Keep the area near the charger clear of obstructions, to allow the fan to operate efficiently.

RESTART

If the Charge Mode is changed after charging has started (by pressing the RATE SELECTION or BATTERY TYPE button), the charging process will restart.

12. DISPLAY MESSAGES

DIEHARD – Scrolls twice upon startup.

CONNECT CLAMPS (VOLTAGE LED lit) – Plugged into the AC outlet without the clamps connected to a 6 or 12V battery.

WARNING CLAMPS REVERSED (Red REVERSED LED lit) – Plugged into the AC outlet and the clamps are connected backwards to a battery. Scrolls until condition is corrected.

ANALYZING BATTERY (Yellow/orange CHARGING LED lit) – Plugged into the AC outlet, and when first connected to a 6 or 12V battery correctly.

CHARGING 6V – XX% (Yellow/orange CHARGING LED lit) – Plugged into the AC outlet and correctly connected to a discharged 6V battery.

CHARGING 12V – XX% (Yellow/orange CHARGING LED lit) – Plugged into the AC outlet and correctly connected to a discharged 12V battery.

FULLY CHARGED AUTO MAINTAINING (Green CHARGED/MAINTAINING LED solid) – Plugged into the AC outlet and correctly connected to a fully charged 6 or 12V battery.

CHARGING ABORTED BAD BATTERY (Yellow/orange CHARGING LED flashing) – Circumstances that could cause an Abort situation during charging:

- The battery is severely sulfated or has a shorted cell and can't reach a full charge.
- The battery is too large or there is a bank of batteries and it doesn't reach full charge within a set time period.

Circumstances that could cause an Abort situation during maintaining:

- The battery is severely sulfated or has a weak cell and will not hold a charge.
- There is a large draw on the battery and the charger has to supply its maximum maintain current for a 12 hour period to keep the battery at full charge.

LIFE DEMANDS DIEHARD – Charging is complete and clamps have been disconnected.

ENGINE START READY (BATTERY TYPE LED lit) – The charger is ready for engine start.

ENGINE START COOL DOWN XXX SECONDS REMAINING (BATTERY TYPE LED lit) – The charger is in a mandatory 3 minute (180 second) cool down state.

13. MAINTENANCE AND CARE

A minimal amount of care can keep your battery charger working properly for years.

- Clean the clamps each time you are finished charging. Wipe off any battery fluid that may have come in contact with the clamps to prevent corrosion.
- Occasionally cleaning the case of the charger with a soft cloth will keep the finish shiny and help prevent corrosion.

- Coil the input and output cords neatly when storing the charger. This will help prevent accidental damage to the cords and charger.
- Store the charger unplugged from the AC power outlet in an upright position.
- Store the clamps on the storage areas provided on the handle. Do not store the clamps clipped together, on or around metal, or clipped to the cables.

14. TROUBLESHOOTING

PROBLEM	POSSIBLE CAUSE	REASON/SOLUTION
The charger will not turn on when properly connected.	AC outlet is dead.	Check for open fuse or circuit breaker supplying AC outlet.
	Poor electrical connection.	Check power cord and extension cord for loose fitting plug.
	Battery is defective.	Have battery checked.

PROBLEM	POSSIBLE CAUSE	REASON/SOLUTION
Battery clamps do not spark when touched together.	The charger is equipped with an auto-start feature. It will not supply current to the battery clamps until a battery is properly connected. The clamps will not spark if touched together.	No problem; this is a normal condition.
The battery is connected and the charger is on, but is not charging.	The charger is in tester mode, not charge mode.	Press the RATE SELECTION button to activate the charge mode and select a charge rate.
No reading on the digital display.	Charger is not plugged in. No power at the receptacle.	Plug the charger into an AC outlet. Check for open fuse or circuit breaker supplying AC outlet.
Digital Display reads LOW when testing the alternator.	The alternator output is 13.2 volts or less.	Have the electrical system checked by a qualified technician.
Digital Display reads HIGH when testing the alternator.	The alternator output is 14.6 volts or more.	Have the electrical system checked by a qualified technician.
Yellow/orange CHARGING LED is solid and the display shows ANALYZING BATTERY .	The charger needs to check the condition of the battery.	The yellow/orange LED will be solid when the charger is checking the condition of the battery.
Yellow/orange CHARGING LED is flashing and the display shows CHARGE ABORTED BAD BATTERY .	The battery is sulfated. The battery is too large for the charger.	Reset the charger by briefly unplugging it. You need a charger with a higher amp rate.
The display shows CONNECT CLAMPS .	The clamps are not making a good connection.	Check for poor connection at battery and frame.
Short or no start cycle when cranking engine.	No power at receptacle. AC cord and/or extension cord is loose. The clamps are not making a good connection. Failure to wait 3 minutes between cranks. The battery may be severely discharged. The battery is drawing more than the engine start rate. The charger may be overheated.	Check for open fuse or circuit breaker supplying AC outlet. Check power cord and extension cord for loose fitting plug. Check for poor connection at battery and frame. Wait 3 minutes of rest time before the next crank. On a severely discharged battery, charge for 10 to 15 minutes in the 60A rate, to help assist in cranking. Crank time varies with the amount of current drawn. If cranking draws more than the engine start rate, crank time may be less than 5 seconds. The thermal protector may have tripped and needs a little longer to reset. Make sure the charger vents are not blocked. Wait and try again.

15. BEFORE RETURNING FOR REPAIRS

- When a charging problem arises, make certain that the battery is capable of accepting a normal charge. Double check all connections, the AC outlet for a full 120 volts, the charger clamps for correct polarity and the quality of the connections from the cables to the clamps and from the clamps to the battery system. The clamps must be clean.
- When an UNKNOWN OPERATING PROBLEM arises, please read the complete manual and call the customer service number for information. This will usually eliminate the need for return.

**If the above solutions do not eliminate the problem,
or for information about troubleshooting or replacement parts,
call toll-free from anywhere in the U.S.A.**

1-800-732-7764

7:00 am to 5:00 pm CT, Monday through Friday