

7.1 Cubic Foot Chest Freezer

HF71CM33NW



Available

Unit Specifications

Width	37"
Depth	21 5/8"
Height	33 1/4"
Weight	83.3 lbs.
UPC	688057211527

More Easy-To-Use Features

- Hold up to 250lbs of food
- Adjustable thermostat control
- "Power On" Indicator Light
- Easy-Access Defrost Drain
- Space-Saving Flat-Back Design
- Manual Defrost
- Removable Basket

Warranty

- 1 Year Warranty (Parts and Labor)
- 5 Year Sealed System

Available Finishes



White

Signature Features

Storage for up to 250 lbs

Storage space to accommodate all your frozen food needs

Easy Access Defrost Drain

Front drain makes defrosting quick and effortless

Power On Indicator

Indicator light allows the user to know the freezer is operating at a glance

Removable Basket

Allows flexibility when arranging items

Letter	Cutout Dimension	in.
A	Height	33 1/4"
B	Depth	21 5/8"
C	Width	37"

Overall Packaging Details

Packaging	lb./in.	
Gross Weight	90 lb.	
Dimensions	W	39 3/16"
	D	23 1/16"
	H	35 1/16"

Clearances

Back	4"
Sides	4"
Top	Do not block

Power Requirements

Electrical Rating	115V, 60Hz
Energy Use	248kWh
Refrigerant	R600a

Product Technical Illustration

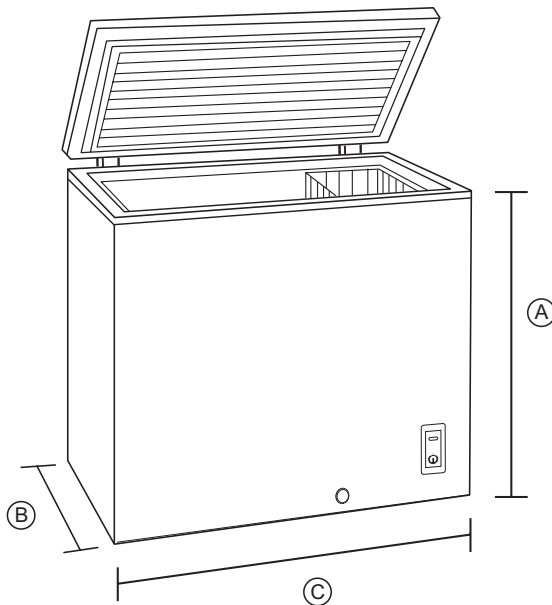

General Appliance Information

Please read all installation details and instructions before use.

Contact Us

For questions regarding this product please refer to our website at haieramerica.com or call our customer service center at 877-337-3639.

