



LIL' E™ ELECTRIC SCOOTER



OWNER'S MANUAL

Read and understand this entire manual before allowing child to use this product! For assistance contact Razor. DO NOT RETURN TO STORE.

NOTE: Manual illustrations are for demonstration purposes only. Illustrations may not reflect exact appearance of actual product. Specifications subject to change without notice.

Please have your product along with the 19 character product I.D. code with you before contacting Razor for warranty assistance and/or replacement parts.

Product I.D. Code: _____ - _____ - _____

CONTENTS

Safety Warnings	1-2	Usage	6
Before You Begin.....	3	Repair and Maintenance.....	7
Assembly and Set-Up.....	4	Product Parts Breakdown.....	8
Charging the battery	5	Warranty Contact Information	9
Pre-Ride Checklist.....	6	Contact Information	11

SAFETY WARNINGS

⚠ AN IMPORTANT MESSAGE TO PARENTS:

Razor® Jr. products are intended to allow younger children to learn and to enjoy their early experiences using electric ride-on toys. Studies suggest that children at age 3 have the coordination required to use a steering wheel or handlebar and can use a 3-wheeled electric product. Adult supervision is required as children learn and grow because children do not understand the risks of riding in areas with cars and are at a very high risk of falling off and injuring themselves.

This manual contains important information. For your child's safety, it is your responsibility to review this information and make sure that you instruct your child to follow all warnings, cautions, instructions and safety topics. Razor USA recommends that you periodically review and reinforce the information in this manual with younger riders, and that you inspect and maintain your child's electric product to ensure their safety.

⚠ WARNING: PARENTAL AND ADULT RESPONSIBILITY AND SUPERVISION IS NECESSARY:

Riding a Lil' E does present potential risks and caution is required. Because products, like the Lil' E, can and do present potential hazards plainly associated with their use, it is well recognized THE NEED FOR EXERCISE OF PARENTAL RESPONSIBILITY IN SELECTING RIDING PRODUCTS APPROPRIATE TO THE AGE OF A CHILD, OR PARENTAL SUPERVISION IN SITUATIONS IN WHICH CHILDREN OF VARIOUS AGES MAY HAVE ACCESS TO THE SAME RIDING PRODUCTS, IS IMPORTANT. Not every product is appropriate for every age or size of child, and different age recommendations are found within this category of product which are intended to reflect the nature of the hazards and the expected mental or physical ability, or both, of a child to cope with the hazards.

Keep this product away from very small children and remember that it is intended for use only by children who are, at a minimum, completely comfortable and competent while operating the Lil' E.

Children with any mental or physical conditions that may make them susceptible to injury, impair their physical dexterity or mental capabilities to recognize, understand, and follow safety instructions and to be able to understand the hazards inherent in Lil' E use, should not use or be permitted to use products inappropriate for their abilities.

⚠ GENERAL WARNING: Electric scooter riding can be a hazardous activity. Certain conditions may cause the equipment to fail without fault of the manufacturer. Electric products can and are intended to move, and it is therefore possible to get into dangerous situations and/or lose control and/or fall. If such things occur you can be seriously injured or die. LIKE ANY OTHER MOVING PRODUCT, USING AN ELECTRIC PRODUCT CAN BE A DANGEROUS ACTIVITY AND MAY RESULT IN INJURY OR DEATH EVEN WHEN USED WITH PROPER SAFETY PRECAUTIONS. RIDE AT YOUR OWN RISK AND USE COMMON SENSE.

This manual contains many warnings and cautions concerning the consequences of failing to maintain, inspect or properly use your Razor Jr. electric product. Because any incident can result in serious injury or even death, we do not repeat the warning of potential serious injury or death each time such a possibility is mentioned.

- This product does not have a brake.
- Do not allow children under age three (3) to use the electric product. Close adult supervision is required. Any rider unable to fit comfortably on the Lil' E should not attempt to ride it.
- Always pay attention to where your child is going; do not allow use of the push button throttle to distract rider from safe riding practices.
- Safety equipment, such as helmet, knee pads and elbow pads are recommended. Always wear a helmet when riding your electric product and keep the chinstrap securely buckled.
- Always wear closed toe shoes.
- Never allow more than one child at a time to ride the electric product.
- Ride on smooth, paved surfaces without loose debris, such as rocks or gravel, and away from motor vehicles.
- Avoid sharp bumps, drainage grates, and sudden surface changes as the Lil' E may suddenly stop.
- Avoid streets and surfaces with water, mud, ice, sand, gravel, dirt, leaves and other debris. Wet weather impairs traction, stopping, and visibility.
- Do not ride at night or when visibility is impaired.
- Avoid excessive speed associated with downhill rides.
- Obey all local traffic and electric scooter laws and regulations.
- Watch out for pedestrians.
- **DO NOT EXCEED 44 LB (20 KG) TOTAL WEIGHT ON THE RAZOR JR. ELECTRIC PRODUCT.**
- **RIDER WEIGHT DOES NOT NECESSARILY MEAN A CHILD'S SIZE IS APPROPRIATE TO FIT OR MAINTAIN CONTROL OF THE ELECTRIC PRODUCT.**
- A parent's decision to allow his or her child to ride this electric product should be based on the child's maturity, skill and ability to follow rules.

CHECK AND MAINTAIN PRODUCT CONDITIONS

The Lil' E should be maintained and repaired in accordance with the manufacturer's specifications, using only the manufacturer's authorized replacement parts, and should not be modified from the manufacturer's original design and configuration.

SAFETY WARNINGS

ACCEPTABLE RIDING PRACTICES AND CONDITIONS

Direct parental supervision is required at all times. Electric products are meant to be used only in controlled environments, free of potential traffic hazards and not on public streets. Do not allow your child to ride an electric product in any areas where vehicle traffic is present. Never use near steps, sloped driveways, hills, roadways, alleys or swimming pool areas.

Do not activate the push button throttle unless child is on the Lil' E and in a safe, outdoor environment suitable for riding.

The normal powered top speed of the Lil' E will be approximately 2 mph (3 km/h), which can be affected by conditions, such as rider weight, inclines, and battery charge level. Avoid excessive speeds that can be associated with downhill rides. Ride on level and flat ground only.

Maintain a hold on the handlebars at all times.

Ride defensively. Watch out for potential obstacles that could catch the wheel or cause the rider to swerve suddenly or lose control. Be careful to avoid pedestrians, skaters, skateboards, electric products, bikes, children or animals who may enter your path, and respect the rights and property of others.

Wet, slick, bumpy, uneven or rough surfaces may impair traction and contribute to possible accidents.

Child must maintain a hold on the handlebars at all times. Never allow more than one child at a time to ride the electric scooter.

Do not allow hands, feet, hair, body parts, clothing, or similar articles to come in contact with moving parts or wheels while the motor is running.

Do not ride your Lil' E in wet or icy weather and never immerse the Lil' E in water, as the electrical and drive components could be damaged by water or create other possibly unsafe conditions. Never risk damaging surfaces, such as carpet or flooring, by use of the Lil' E indoors.

PROPER RIDING ATTIRE

Always ensure child is wearing proper protective equipment, such as an approved safety helmet. A helmet may be legally required by local law or regulation in your area. A long-sleeved shirt, long pants, and gloves are recommended. Always wear athletic shoes (lace-up shoes with rubber soles) and keep shoelaces tied and out of the way of the wheels and motor. Knee pads and elbow pads are recommended.

USING THE CHARGER

The charger supplied with the Lil' E should be regularly examined for damage to the cord, plug, enclosure and other parts. In the event of such damage, the Lil' E must not be charged until the charger has been repaired or replaced.

Use only with the recommended charger.

Use caution when charging.

The charger is not a toy. Charger should be operated by an adult.

Do not operate charger near flammable materials.

Unplug charger and disconnect from Lil' E when not in use.

Always disconnect from the charger prior to wiping down and cleaning your Lil' E with damp cloth.

⚠ WARNING: ALWAYS INSPECT ELECTRIC PRODUCT PRIOR TO RIDING. Properly inspecting and maintaining your electric product can reduce the risk of injury. Always inspect your electric product before riding and regularly maintain it. Replace worn parts when they occur.

⚠ WARNING: CHECK LOCAL LAWS REGARDING ELECTRIC SCOOTER USE. Check local laws and regulations to see where and how you may use your electric scooter legally. In many states and local areas electric scooter riders are required BY LAW to wear a helmet. Check local laws and regulations regarding laws governing helmet use and electric scooter operation in your area.

FAILURE TO USE COMMON SENSE AND HEED THE WARNINGS INCREASES RISK OF SERIOUS INJURY. USE AT YOUR OWN RISK. USE WITH APPROPRIATE CAUTION AND SERIOUS ATTENTION TO SAFE OPERATION.

BEFORE YOU BEGIN

Adult assembly required. Remove contents from box. Inspect the contents for scratches in the paint and/or dents that may have occurred during shipping. Because your electric product was partially assembled and packed at the factory, there should not be any problems, even if the box has a few scars or dents.

MAKE SURE POWER SWITCH IS TURNED "OFF" BEFORE CONDUCTING ANY ASSEMBLY OR MAINTENANCE PROCEDURES.

Estimated Assembly and Set-Up Time

Razor recommends assembly by an adult or someone with experience in bicycle mechanics.

Allow up to 10 minutes for assembly, not including initial charge time.

Allow up to 12 hours for charge (see page 5 for charging information).

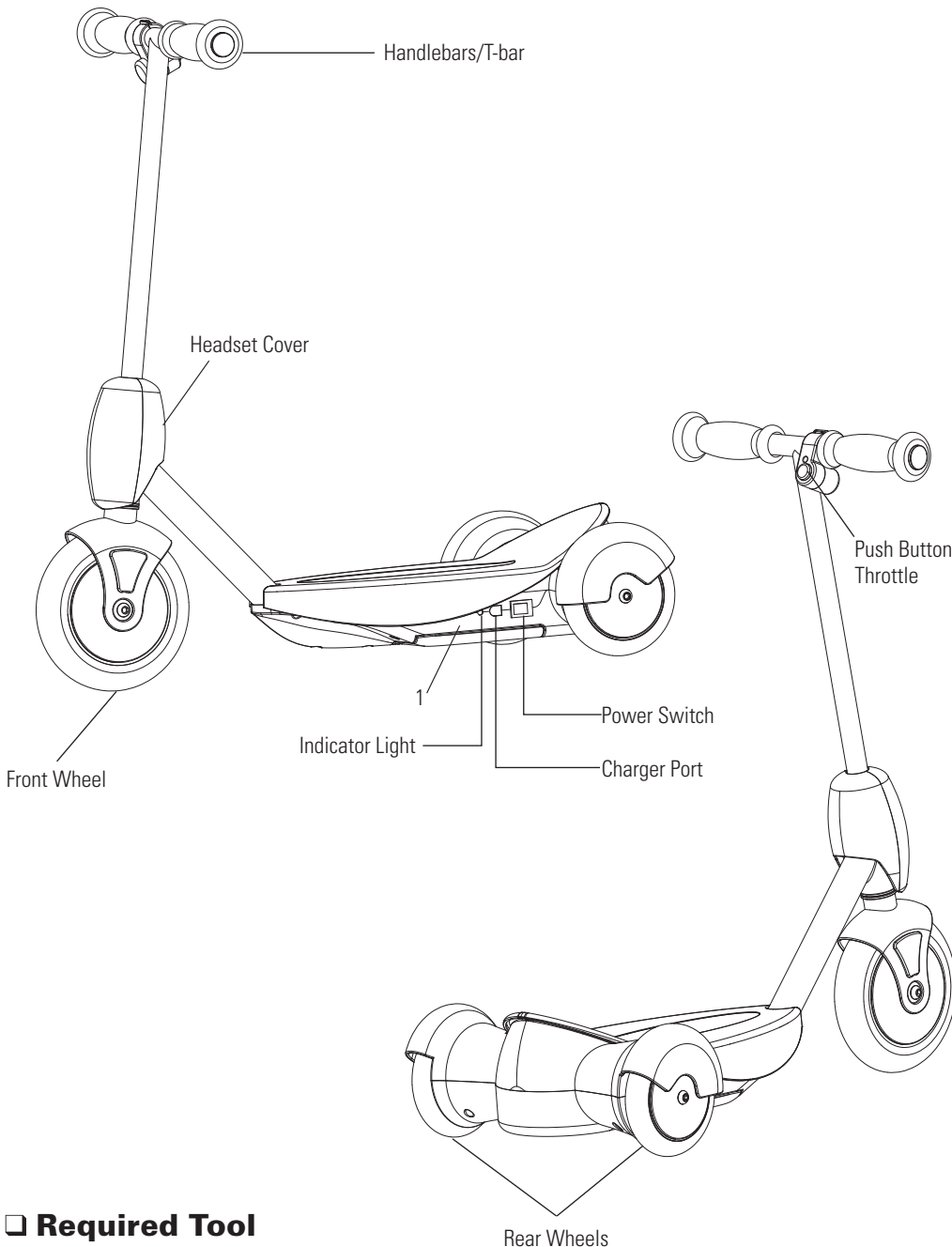

Required Tool

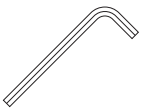

5 mm Allen Wrench

WARNING: DO NOT USE NON-RAZOR PRODUCTS WITH YOUR RAZOR JR Lil' E. Razor Jr products are built to certain Razor design specifications. The original equipment supplied at the time of sale was selected on the basis of its compatibility with the frame and all other parts. Certain aftermarket products may not be compatible and will void the warranty.

Product ID Locations:

1. Frame (Next to charger port)
2. Charger
3. Box (not shown)

Box Contents:

- Lil' E
- Tool
- Owner's Manual
- Charger

Need Help? Visit our web site for replacement parts, product support, a list of authorized service centers in the US and customer service contact information at www.razor.com. Please have the product I.D. code (located on the white label of your product) available for better assistance. Additional Customer Service contact information is listed at the back of this manual.

ASSEMBLY AND SET-UP

Turn power switch OFF before conducting any maintenance procedures.

□ Attaching the Front Wheel/Handlebars

Tool Required: 5 mm Allen wrench

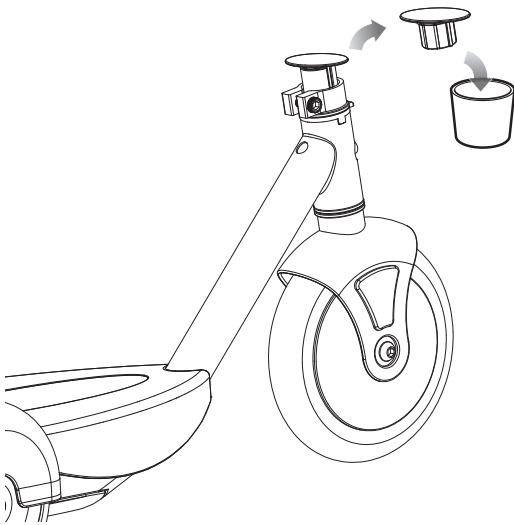

1 Remove and discard plastic cap

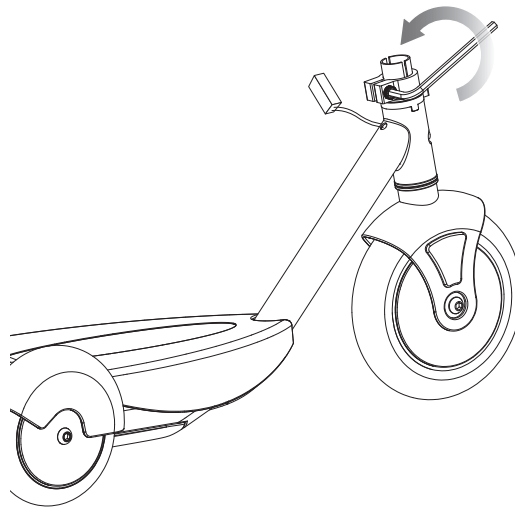

2 Loosen the 5 mm bolt on the collar clamp.

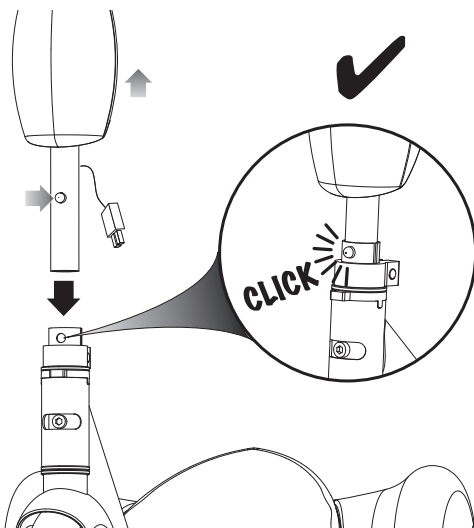

3 Slide the headset cover up. Depress the spring loaded button on the T-bar and insert the T-bar into the front fork until the T-bar is securely locked into place.

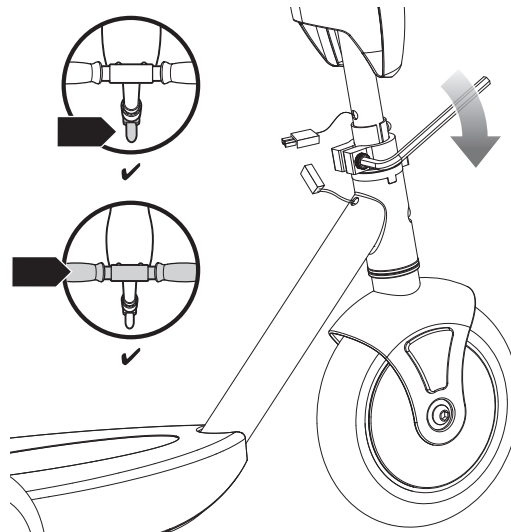

4 With the front wheel pointed straight ahead, the handlebars square to the front wheel and the Razor logo on the T-bar facing the front, tighten the bolt on the collar clamp. Tighten securely.

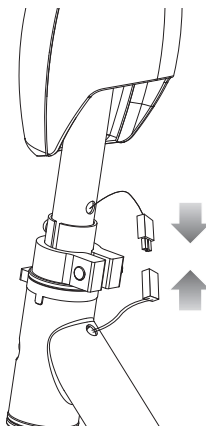

5 Connect the black connector on the T-bar to the black connection on the down tube.

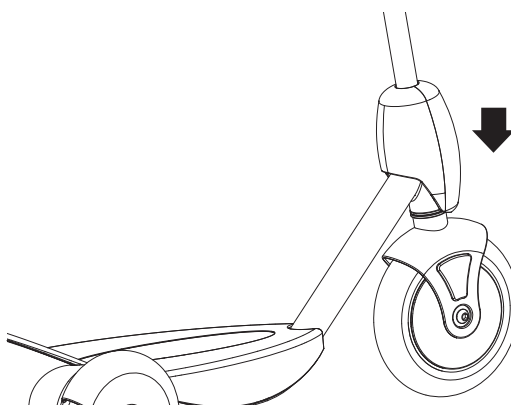

6 Slide headset cover all the way down to cover collar clamp and connectors.

Note: Failure to secure the handlebars can cause the handlebars to come out while riding.

⚠ WARNING: Failure to properly tighten the collar clamp may cause the rider to lose control and fall. If you are having difficulty understanding these instructions, please contact Razor Customer Service for assistance.

CHARGING THE BATTERY

Your Lil' E may not have a fully charged battery; therefore it is a good idea to charge the battery prior to use.

- Initial charge time: 12 hours.
- Recharge time: up to 12 hours. Recommended maximum charging time is 24 hours.
- Always charge the battery immediately after riding.
- Fully charge battery before storing for extended periods of time.
- Unplug charger from the wall outlet when not in use.
- Failure to recharge battery periodically may result in a battery that will not accept a charge.
- Make sure power switch is turned **OFF** when product is not in use. If the power switch is left on for an extended period of time, the battery may reach a stage at which it will no longer hold a charge.
- To ensure long battery life, never store the product in freezing or below freezing temperatures! Freezing will permanently damage the battery.
- Run time: Up to 60 minutes of continuous ride time. Run time may vary depending on riding conditions, rider weight, climate and/or proper maintenance.
- Constant stopping and starting may shorten ride time.
- Battery life can vary depending on proper maintenance and usage of the product.
- Only use the battery specified by Razor.

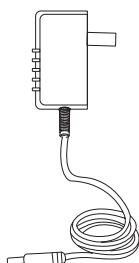

Charger

Note:
Charger design may vary from one shown

Make sure power switch is in the **OFF** position.

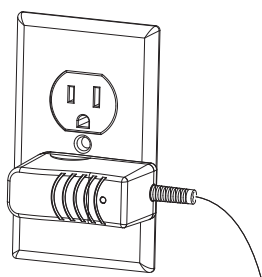

1 Plug the charger plug into wall outlet.

Note: The light on the charger will **NOT** light up until the charger is plugged into the product.

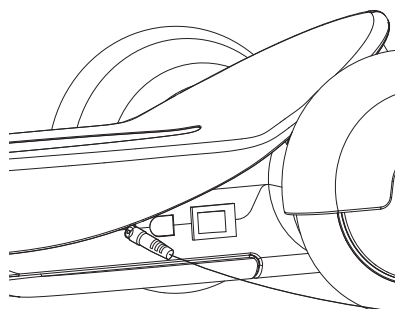

2 Plug the charger into the charger port. The light on the charger should turn red during charging. The light on the charger will turn **OFF** when charging is completed.

Note: The indicator light located next to the charger port will turn red when charger is plugged into the wall outlet and product. Light will turn OFF when charger is removed from product.

⚠ WARNING: Use **ONLY** with the recommended charger. Battery is only to be charged by an adult. The charger is not a toy. Always disconnect the charger before wiping down and/or cleaning the Lil' E with a damp cloth. The charger supplied with the Lil' E should be regularly examined for damage to the cord, plug, enclosure and other parts. In the event of such damage, the Lil' E must not be charged until it has been repaired or replaced.

Note: If the charger gets warm during regular use, this is a normal response and is no cause for concern. If your charger does not get warm during use, it does not mean that it is not working properly.

Wall outlet - No Light
Wall outlet and product - Red (charging)
Wall outlet and product - No Light (charging complete)

⚠ WARNING: Failure to recharge the battery at least once a month may result in a battery that will no longer accept a charge.

PRE-RIDE CHECKLIST



Frame and Handlebars

Check for cracks or broken connections. Although broken frames are rare, it is possible for an aggressive rider to run into a curb or object and wreck and bend or break. Get in the habit of inspecting your electric product on a regular basis.



Hardware/Loose Parts

Before every ride, check all parts, such as nuts, bolts, cables, fasteners, etc., to ensure they are secure and assembled correctly. There should not be any unusual rattles or sounds from loose parts or broken components. If the product is damaged, do not ride. **Reference "Safety Warnings" on pages 1 and 2 of this manual.**



Safety Gear

Always wear proper protective gear, such as an approved safety helmet. Elbow pads and kneepads are recommended. Always wear closed toe shoes (lace-up with rubber soles) and keep shoelaces tied and out of the way of the wheels. **NEVER RIDE BAREFOOTED OR IN SANDALS.**



Laws and Regulations

Always check and obey any local laws or regulations.



Be Careful!

This product is not for aggressive or trick riding. Avoid steep inclines and don't ride too fast — you can lose control and fall. Skateboard parks are not designed for young riders. Never ride in traffic or on the street and watch your surroundings for pedestrians, skaters, skate boards, electric products, bikes, children or animals who may enter your path and respect the rights and property of others.

Maintain a hold on the handlebars at all times.

USAGE

How to Ride

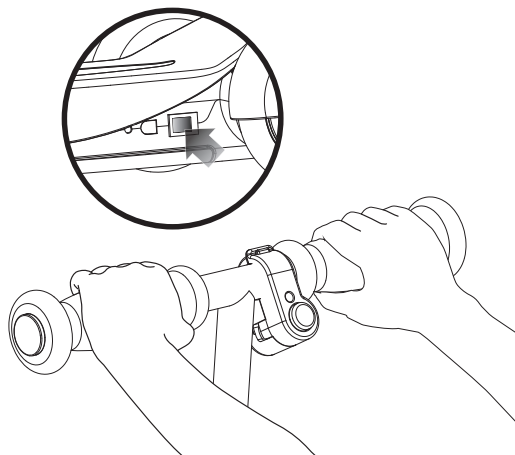

- 1 Turn power switch **ON**; place both hands on the handlebars and both feet on the deck plate.
Note: Power switch should be turned on by an adult.

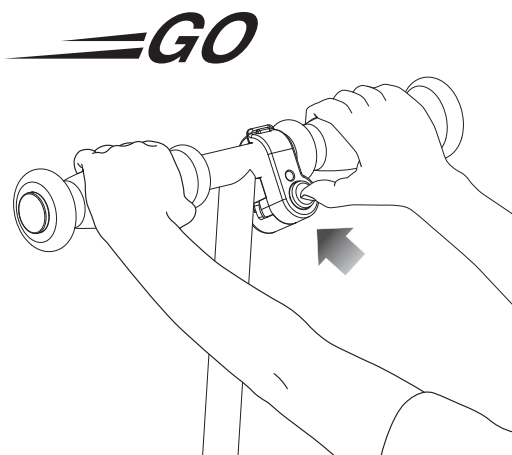

- 2 Press the push button throttle to make product go.

⚠ WARNING: Supervising adult should help child to understand how the "power" switch and "throttle button" are both needed to generate.

Make sure the push button throttle is **NOT** depressed when turning the power switch on.

Once the power switch is in the **ON** position, pushing the throttle button will cause the product to move.

How to Stop

Release the push button throttle to stop product.

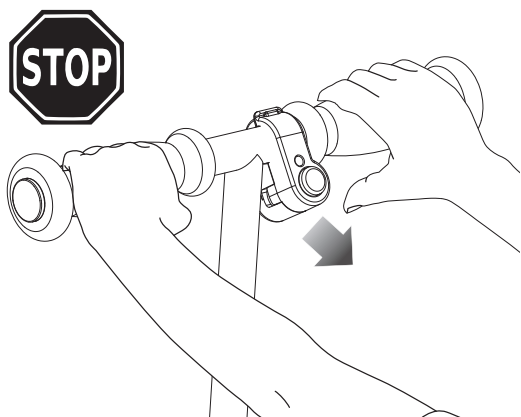

REPAIR AND MAINTENANCE

Battery Care and Disposal

Do not store in freezing or below freezing temperatures! To properly maintain your battery and ensure maximum battery life, carefully read the "Charging the Battery" section on page 5 of this owner's manual.



CONTAINS SEALED LEAD ACID BATTERIES. BATTERIES MUST BE RECYCLED.

Disposal: Your Razor product uses sealed lead-acid batteries which must be recycled or disposed of in an environmentally safe manner. Do not dispose of a lead-acid battery in a fire. The battery may explode or leak. Do not dispose of a lead-acid battery in your regular household trash. The incineration, land filling or mixing of sealed lead-acid batteries with household trash is prohibited by law in most areas. Return exhausted batteries to a federal or state approved lead-acid battery recycler or a local seller of automotive batteries. If you live in Florida or Minnesota, it is prohibited by law to throw away lead-acid batteries in the municipal waste stream.

Charger

The charger supplied with the electric product should be regularly examined for damage to the cord, plug, enclosure and other parts and in the event of such damage, the product must not be charged until it has been repaired or replaced.

Use ONLY with the recommended charger.

Cleaning

Wipe with a damp cloth to remove dirt and dust. Do not use industrial cleaners or solvents, as they may damage the surfaces. Do not use alcohol, alcohol-based or ammonia-based cleaners, as they may damage or dissolve the plastic components or soften the decals or decal adhesive.

Wheels

Under normal circumstances and conditions, Razor wheels are maintenance free. Nonetheless, it is the responsibility of the owner or guardian to periodically inspect the wheels for wear and tear, and for loose parts. When a wheel develops play, this is an indication of excess wear and replacement is necessary. Replace immediately with only genuine Razor wheels. Worn wheels are considered normal wear-and-tear and are not covered by the Razor Warranty. Wheels other than genuine Razor wheels may not be compatible with your Razor Jr Lil' E. The use of anything other than genuine Razor replacement parts may affect your safety and will void your warranty.

Replacement Parts

The most frequently requested replacement parts are available for purchase at some Razor retail partners. For the complete selection of replacement parts visit shop.razor.com.

Repair Centers

For a list of authorized Razor repair centers:

- Check online at www.razor.com.
- Additional Customer Service contact information is listed at the back of this manual.

⚠ WARNING: If a battery leak develops, avoid contact with the leaking acid and place the damaged battery in a plastic bag. Refer to the disposal instructions at left. If acid comes into contact with skin or eyes, flush with cool water for at least 15 minutes and contact a physician.

⚠ WARNING: Battery posts, terminals and related accessories contain lead and lead compounds. **Wash your hands after handling.**

Need Help? Visit our web site for replacement parts, product support, a list of authorized service centers in the US and customer service contact information at www.razor.com. Please have the product I.D. code (located on the white label of your product) available for better assistance. Additional Customer Service contact information is listed at the back of this manual.

PRODUCT PARTS

Keep your Lil' E running for years with genuine Razor parts. Visit our web site or e-mail us for more information on spare part availability. (Specifications subject to change without notice.)

- | | | |
|--------------------------|---------------------------------|----------------------|
| 1. Handlebars/T-bar | 8. Battery Strap | 12. Motor |
| 1-1 Push Button Throttle | 9. Battery Cover | 13. Rear Wheels (X2) |
| 2. Handlebar Grips (X2) | 10. Battery | |
| 3. End Cap (X2) | 11. Circuit Board | |
| 4. Headset Cover | 11-1 Power Switch | |
| 5. Collar Clamp | 11-2 Charger Port | |
| 6. Front Fork w/Limiter | 11-3 Indicator Light (Charging) | |
| 7. Front Wheel | | |

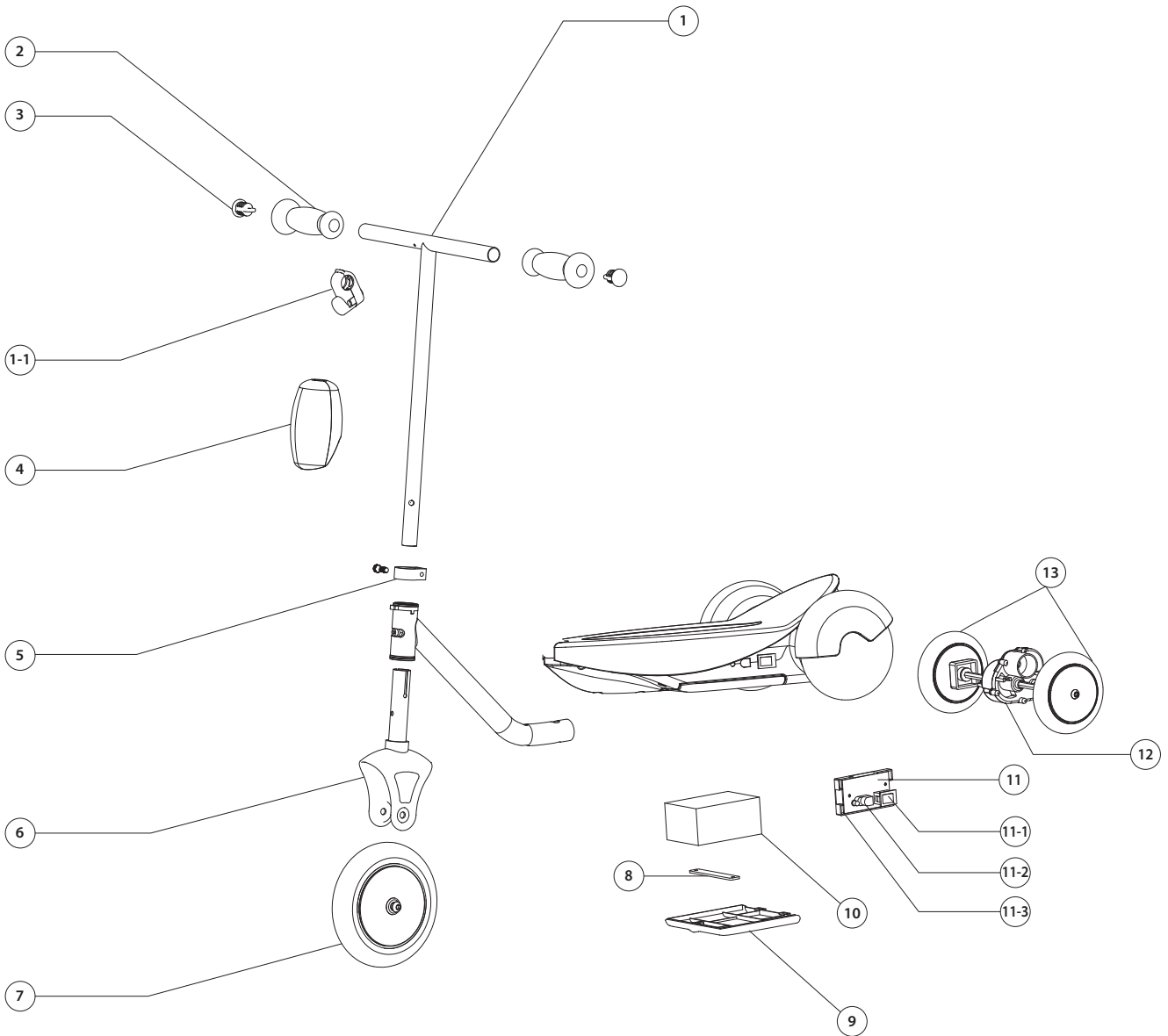

FCC COMPLIANCE

This device complies with Part 15 of the FCC Rules. Operation is subject to the following two conditions: (1) This device may not cause harmful interference, and (2) this device must accept any interference received, including interference that may cause undesired operation.

Note: This equipment has been tested and found to comply with the limits for a Class B digital device, pursuant to part 15 of the FCC Rules. These limits are designed to provide reasonable protection against harmful interference in a residential installation. This equipment generates, uses and can radiate radio frequency energy and, if not installed and used in accordance with the instructions, may cause harmful interference to radio communications. However, there is no guarantee that interference will not occur in a particular installation. If this equipment does cause harmful interference to radio or television reception, which can be determined by turning the equipment off and on, the user is encouraged to try to correct the interference by one or more of the following measures:

- Reorient or relocate the receiving antenna.
- Increase the separation between the equipment and receiver.
- Connect the equipment into an outlet on a circuit different from that to which the receiver is connected.
- Consult the dealer or an experienced radio/TV technician for help.

⚠ WARNING: Changes or modifications to this product not expressly approved by Razor USA, could void the user's authority to operate the equipment.

WARRANTY

Razor Limited Warranty

The manufacturer warrants this product to be free of manufacturing defects for a period of 90 days from date of purchase. This Limited Warranty does not cover normal wear and tear, or any damage, failure or loss caused by improper assembly, maintenance, or storage.

This Limited Warranty will be void if the product is ever:

- used in a manner other than for recreation or transportation;
- modified in any way;
- rented.

The manufacturer is not liable for incidental or consequential loss or damage due directly or indirectly to the use of this product.

Razor does not offer an extended warranty. If you have purchased an extended warranty, it must be honored by the store at which it was purchased.

For your records, save your original sales receipt with this manual and write the serial number below.

NOTICE: INSURANCE

YOUR INSURANCE POLICIES MAY NOT PROVIDE COVERAGE FOR ACCIDENTS INVOLVING THE USE OF THIS SCOOTER/ELECTRIC RIDE-ON PRODUCT. TO DETERMINE IF COVERAGE IS PROVIDED, YOU SHOULD CONTACT YOUR INSURANCE COMPANY OR AGENT.

CUSTOMER SERVICE CONTACT INFORMATION

Need Help? Visit our web site for replacement parts, product support, a list of authorized service centers in the US and customer service contact information at www.razor.com. Please have the product I.D. code (located on the white label of your product) available for better assistance. Additional Customer Service contact information is listed below:

AMERICAS

Razor USA LLC
P.O. Box 3610
Cerritos, CA 90703
USA

+1 866 467 2967
Monday - Friday
8:00 AM - 5:00 PM Pacific Time

EUROPE

Razor USA LLC (Europe)
Handelsweg 2
2742 RD Waddinxveen
Netherlands

+44 (0) 120 267 2702

ASIA

Razor USA LLC (Asia)
P.O. Box 3610
Cerritos, CA 90703
USA

+81 50 7579 6622
info@razor-asia.com

DISTRIBUTED IN THE UK BY:

Re:creation Limited
2 Meadows Business Park
Station Approach, Blackwater
Camberley, Surrey GU17 9AB
United Kingdom

+44 (0) 118 973 6222 *Tel*
+44 (0) 118 973 6220 *Fax*
sales@recreationltd.co.uk

DISTRIBUTED IN AUSTRALIA BY:

Funtastic Limited
Level 2, Tower 2, Chadstone Place
1341 Dandenong Road
Chadstone VIC 3148
Australia

+1 800 244 543
info@funtastic.com.au

Printed in China for Razor USA LLC

Copyright © 2003-2016 Razor USA, LLC. All rights reserved. Razor and the Razor logo design are among the registered trademarks of Razor USA LLC in the United States and/or select foreign countries. Lil' E™ is trademarks of Razor USA LLC.