



# XR 10.9

[www.workoutwarehouse.com](http://www.workoutwarehouse.com)

Model No. GGBE0969.0

Serial No. \_\_\_\_\_

Write the serial number in the space above for reference.

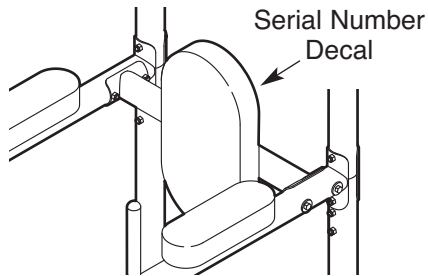

## USER'S MANUAL

### QUESTIONS?

If you have questions, or if parts are damaged or missing, **DO NOT CONTACT THE STORE**; please contact Customer Care.

**IMPORTANT:** Please register this product (see the limited warranty on the back cover of this manual) before contacting Customer Care.

CALL TOLL-FREE:

**1-877-776-4777**

Mon.–Fri. 6 a.m.–6 p.m. MT

Sat. 8 a.m.–4 p.m. MT

ON THE WEB:

[www.workoutwarehouse.com](http://www.workoutwarehouse.com)

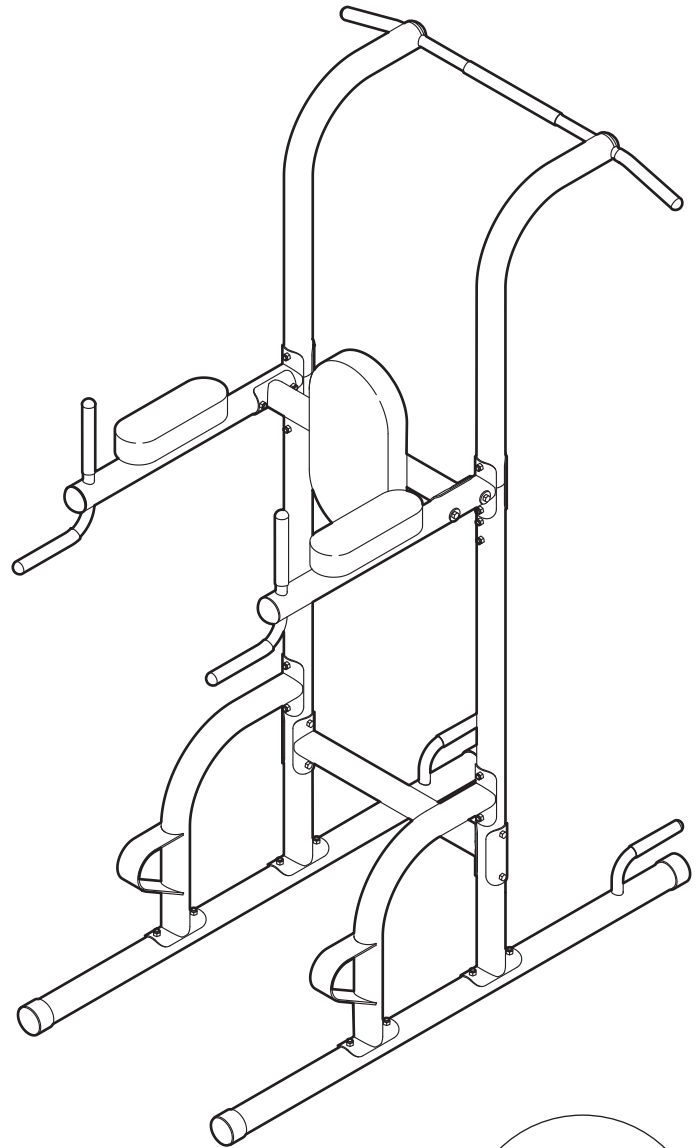

### CAUTION

Read all precautions and instructions in this manual before using this equipment. Save this manual for future reference.



# TABLE OF CONTENTS

WARNING DECAL PLACEMENT .....	2
IMPORTANT PRECAUTIONS .....	3
BEFORE YOU BEGIN .....	4
PART IDENTIFICATION CHART .....	5
ASSEMBLY .....	6
EXERCISE GUIDELINES .....	11
PART LIST .....	14
EXPLODED DRAWING .....	15
ORDERING REPLACEMENT PARTS .....	Back Cover
LIMITED WARRANTY .....	Back Cover

## WARNING DECAL PLACEMENT

This drawing shows the location(s) of the warning decal(s). **If a decal is missing or illegible, see the front cover of this manual and request a free replacement decal. Apply the decal in the location shown.** Note: The decal(s) may not be shown at actual size.

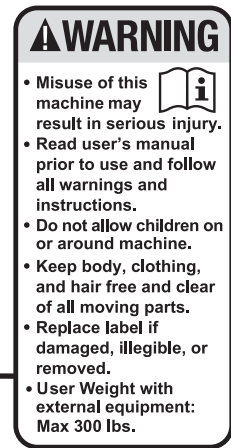
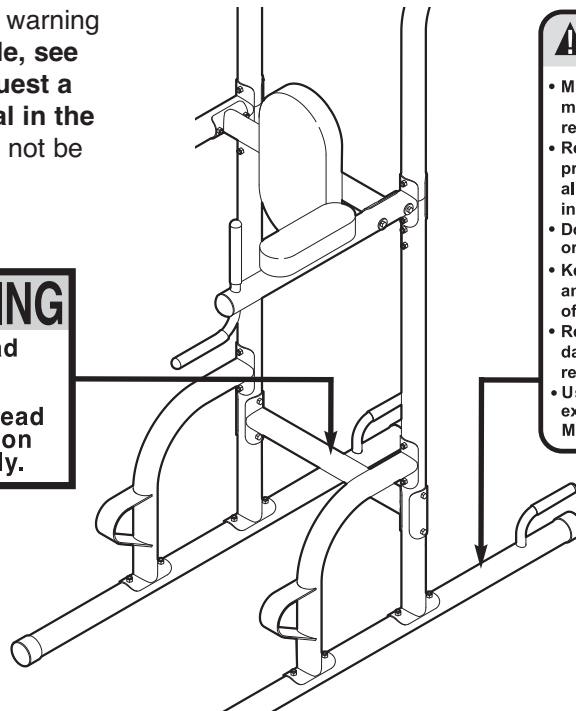

---

# IMPORTANT PRECAUTIONS

**⚠️ WARNING:** To reduce the risk of serious injury, read all important precautions and instructions in this manual and all warnings on the exercise rack before using the exercise rack. ICON assumes no responsibility for personal injury or property damage sustained by or through the use of this product.

1. Before beginning any exercise program, consult your physician. This is especially important for persons over age 35 or persons with pre-existing health problems.
2. Use the exercise rack only as described in this manual.
3. It is the responsibility of the owner to ensure that all users of the exercise rack are adequately informed of all precautions.
4. The exercise rack is intended for home use only. Do not use the exercise rack in a commercial, rental, or institutional setting.
5. Keep the exercise rack indoors, away from moisture and dust. Do not put the exercise rack in a garage or covered patio, or near water.
6. Use the exercise rack only on a level surface. Cover the floor beneath the exercise rack to protect the floor.
7. Make sure that there is enough clearance around the exercise rack to mount, dismount, and use the exercise rack.
8. Make sure that all parts are properly tightened each time the exercise rack is used. Replace any worn parts immediately.
9. Keep children under age 12 and pets away from the exercise rack at all times.
10. The exercise rack is designed to support a maximum user weight of 300 lbs. (136 kg).
11. Always wear athletic shoes for foot protection while exercising.
12. If you feel pain or dizziness while exercising, stop immediately and cool down.

# BEFORE YOU BEGIN

Thank you for selecting the versatile GOLD'S GYM® XR 10.9 exercise rack. The XR 10.9 exercise rack is designed to help you develop the major muscle groups of the upper body. Whether your goal is a shapely figure, a dramatic increase in muscle size and strength, or a healthier cardiovascular system, the exercise rack will help you achieve the specific results you want.

**For your benefit, read this manual carefully before using the exercise rack.** If you have questions after

reading this manual, please see the front cover of this manual. To help us assist you, note the product model number and serial number before contacting us. The model number and the location of the serial number decal are shown on the front cover of this manual.

Before reading further, please review the drawing below and familiarize yourself with the parts that are labeled.

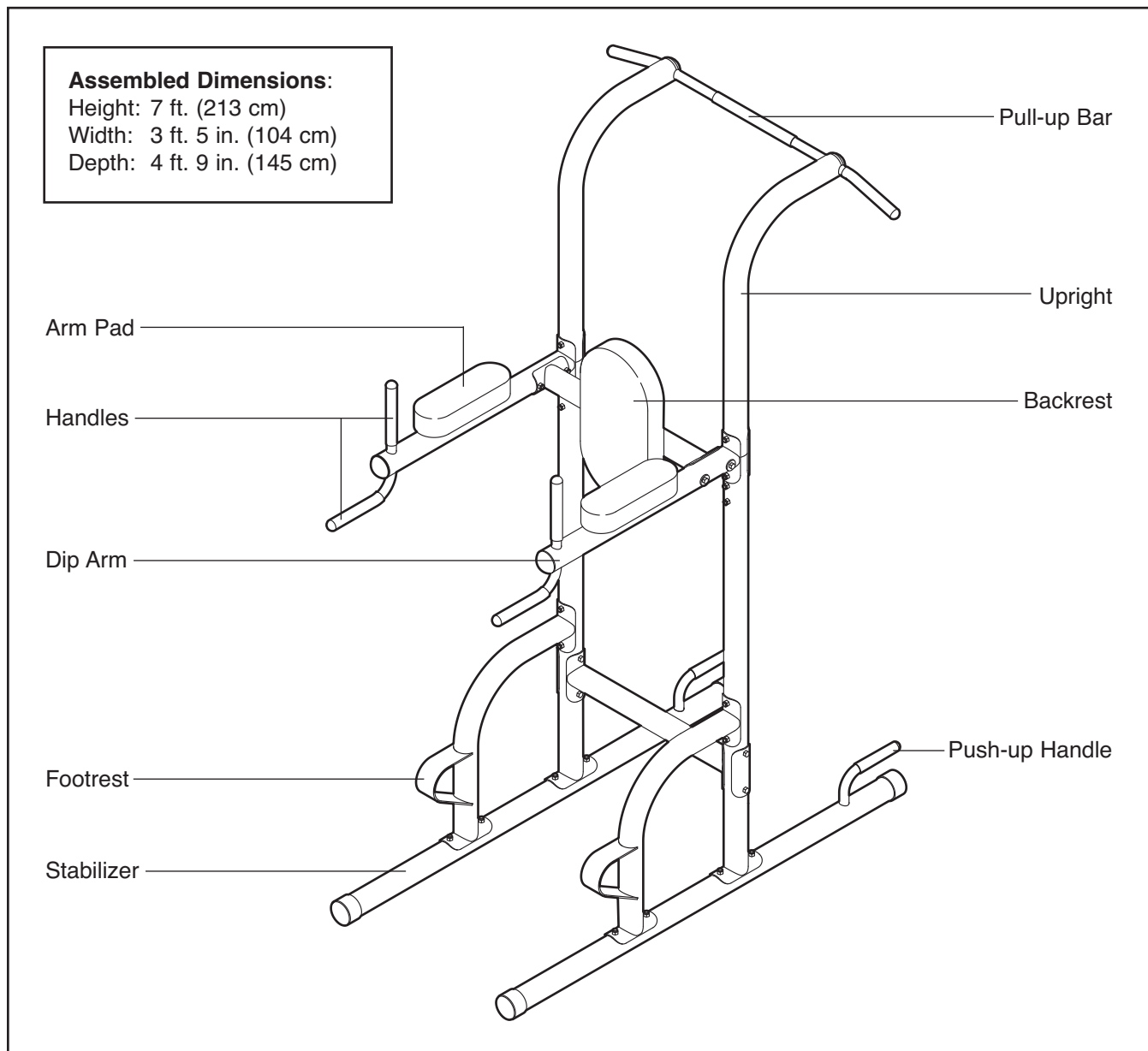

# PART IDENTIFICATION CHART

See the drawings below to identify small parts used in assembly. The number in parentheses by each drawing is the key number of the part from the PART LIST near the end of this manual. **Note: If a part is not in the hardware kit, check to see if it has been preattached.**

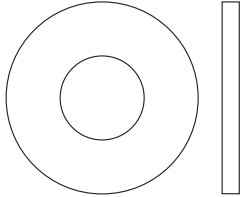

M10 Washer (26)

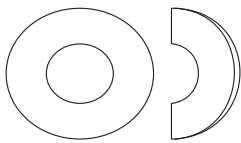

M8 Washer (23)

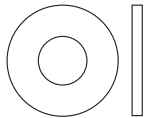

M6 Washer (21)



M8 Locknut (22)



M6 x 16mm Screw (27)



M10 x 50mm Screw (19)



M8 x 68mm Bolt (24)

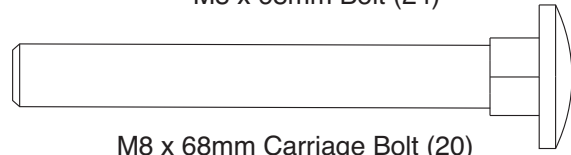

M8 x 68mm Carriage Bolt (20)



M6 x 73mm Screw (18)

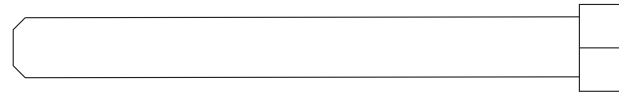

M8 x 75mm Bolt (17)

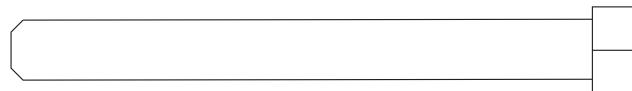

M8 x 77mm Bolt (28)

# ASSEMBLY

## Make Assembly Easier

Everything in this manual is designed to ensure that the exercise rack can be assembled successfully by almost anyone. By setting aside plenty of time, assembly will go smoothly.

Before beginning assembly, carefully read the following information and instructions:

- To hire an authorized service technician to assemble the exercise rack, call 1-800-445-2480.
- Assembly requires two persons.
- Place all parts in a cleared area and remove the packing materials. Do not dispose of the packing materials until assembly is completed.

- To identify small parts, use the PART IDENTIFICATION CHART on page 5.
- Tighten all parts as you assemble them, unless instructed to do otherwise.
- In addition to the included tools, assembly requires the following tools (not included):

two adjustable wrenches 

one rubber mallet 

one standard screwdriver 

one Phillips screwdriver 

Assembly will be more convenient if you have a socket set, a set of open-end or closed-end wrenches, or a set of ratchet wrenches.

1. **Before beginning assembly, make sure that you understand the information in the box above. IMPORTANT: Some of the parts described in the assembly steps may be preassembled.**

Insert four M8 x 68mm Carriage Bolts (20) up through a Stabilizer (1) as shown.

**Repeat this step with the other Stabilizer (not shown).**

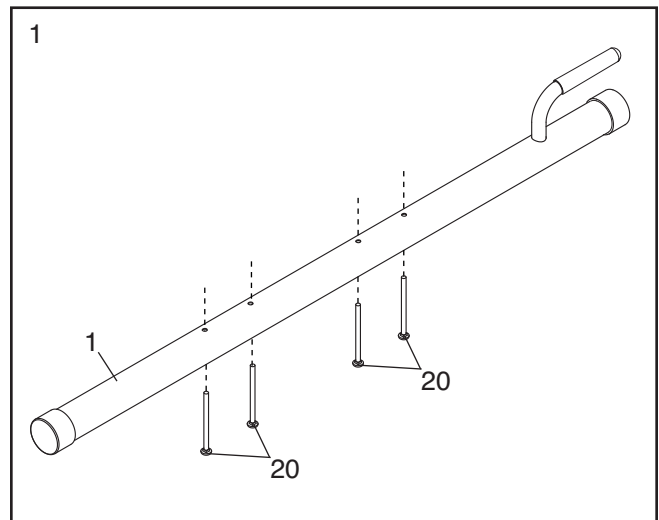

2. Attach an Upright Base (2) to one of the Stabilizers (1) with the indicated two M8 x 68mm Carriage Bolts (20) and two M8 Locknuts (22).  
**Note: Attach the Upright Base so that the hexagonal holes are on the indicated side. Do not tighten the Locknuts yet.**

**Attach the other Upright Base (not shown) to the other Stabilizer (not shown) in the same way.**

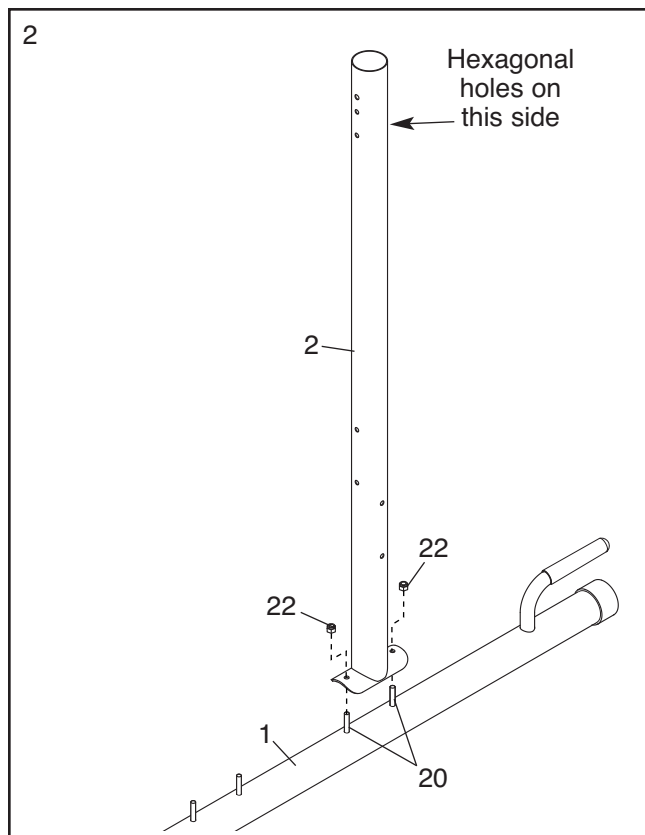

3. Orient the Bottom Crossbar (10) so that the warning decal is on top. Attach the Bottom Crossbar to one of the Upright Bases (2) with two M8 x 77mm Bolts (28), a Support Plate (13), and two M8 Locknuts (22). **Do not tighten the Locknuts yet.**

**Attach the Bottom Crossbar (10) to the other Upright Base (2) in the same way.**

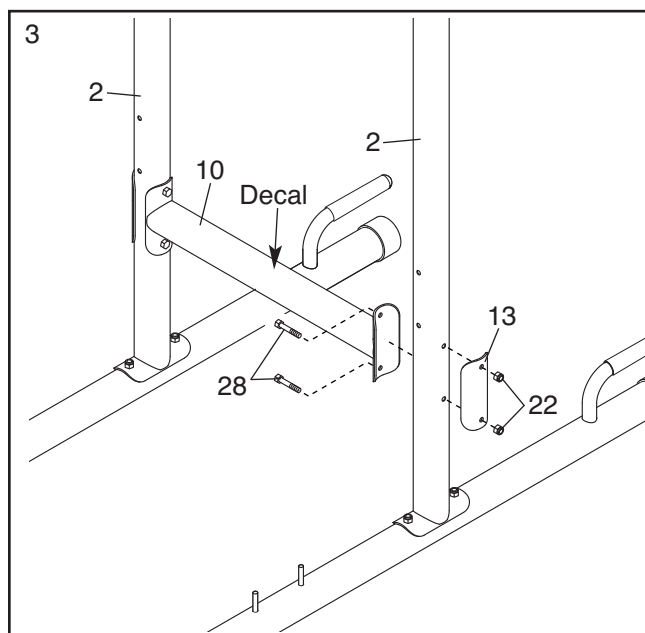

4. Attach a Support (4) to one of the Stabilizers (1) with the two indicated M8 x 68mm Carriage Bolts (20) and two M8 Locknuts (22); **do not tighten the Locknuts yet.**

Next, attach the Support (4) to the Upright Base (2) with two M8 x 75mm Bolts (17), two M8 Washers (23), and two M8 Locknuts (22); **do not tighten the Locknuts yet.**

**Attach the other Support (4) to the other Stabilizer (not shown) and the other Upright Base (2) in the same way.**

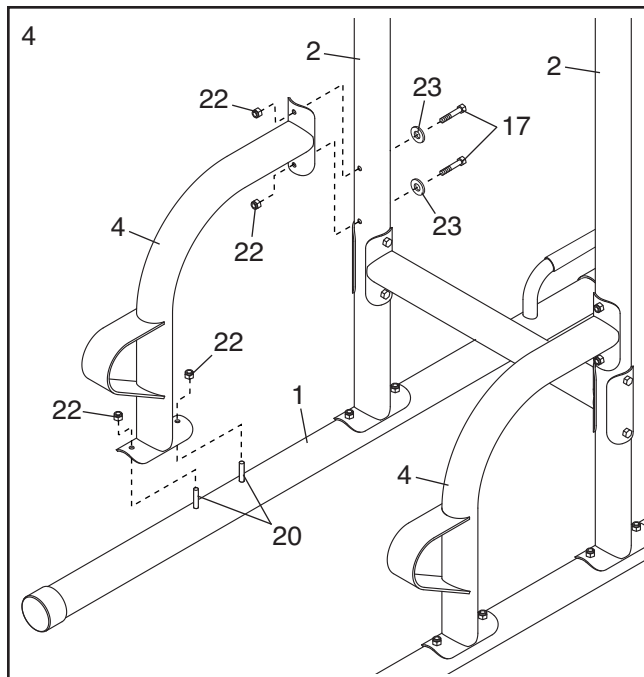

5. Orient one of the Uprights (3) as shown, and attach it to one of the Upright Bases (2) with two M8 x 68mm Bolts (24), two M8 Washers (23), and two M8 Locknuts (22). **Note: The Bolts must be attached in the lowest set of holes in the Upright and the Upright Base. Make sure that the bolt heads are in the hexagonal holes in the Upright Base. Do not tighten the Locknuts yet.**

**Attach the other Upright (3) to the other Upright Base (2) in the same way.**

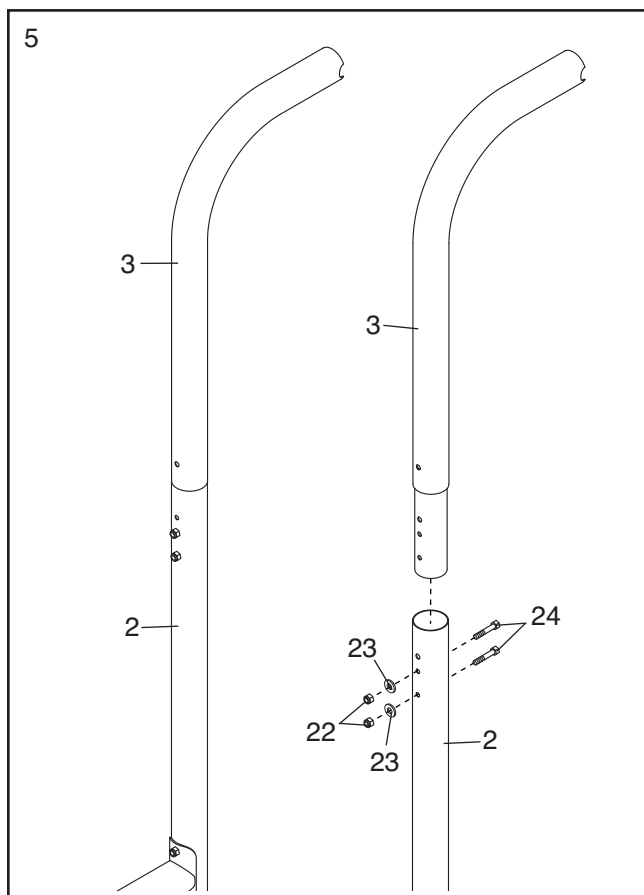

6. Attach a Dip Arm (5) to the right Upright (3) and the Upright Base (2) with two M8 x 77mm Bolts (28), a Support Plate (13), and two M8 Locknuts (22); **do not tighten the Locknuts yet.**

**Repeat this step with the other Dip Arm (5) and the left Upright (not shown).**

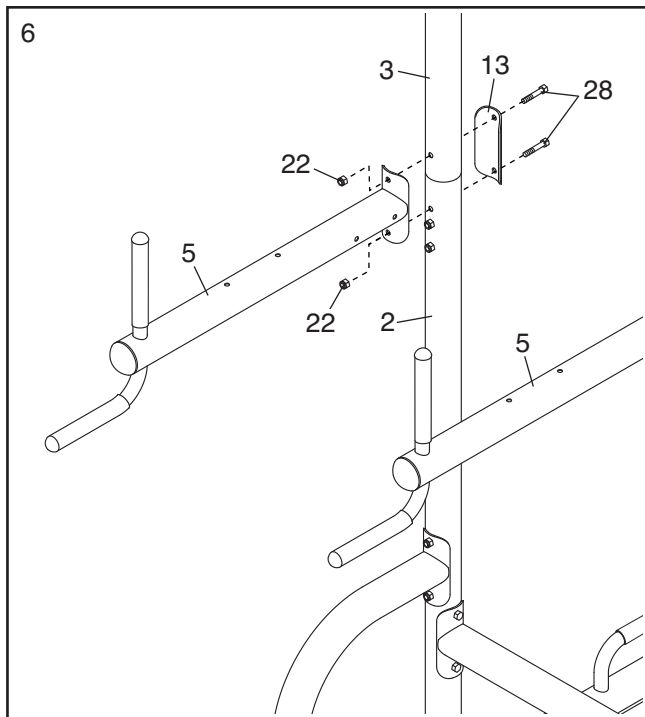

7. Attach the Top Crossbar (7) to one of the Dip Arms (5) with two M8 x 75mm Bolts (17), two M8 Washers (23), and two M8 Locknuts (22); **do not tighten the Locknuts yet.**

**Attach the Top Crossbar (7) to the other Dip Arm (5) in the same way.**

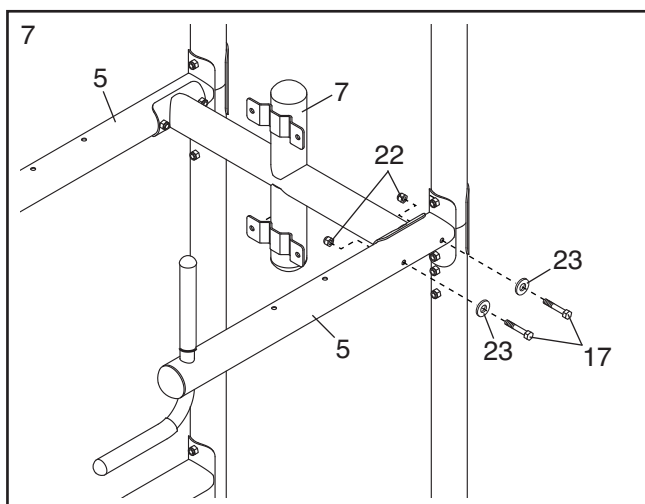

8. Attach the Pull-up Bar (9) to the Uprights (3) with two M10 x 50mm Screws (19) and two M10 Washers (26). **Make sure that the indented holes in the Pull-up Bar are on the side shown.** Then, press the two Rubber Caps (12) into the ends of the Uprights.

**See steps 2–7. Tighten all the M8 Locknuts (22).**

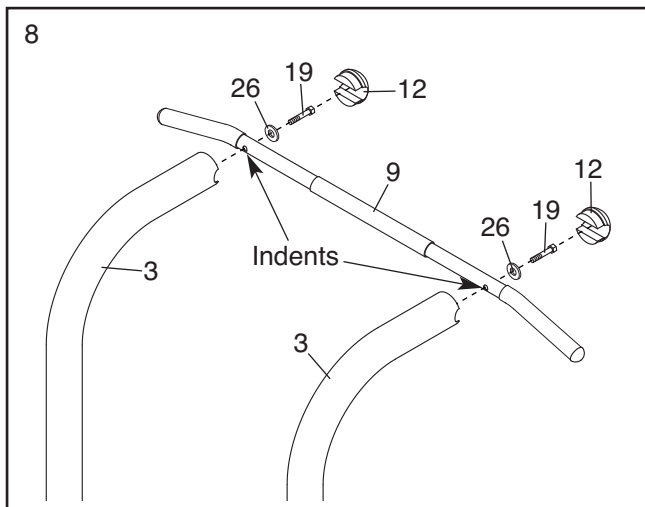

9. Attach the Backrest (8) to the Top Crossbar (7) with four M6 x 16mm Screws (27) and four M6 Washers (21).

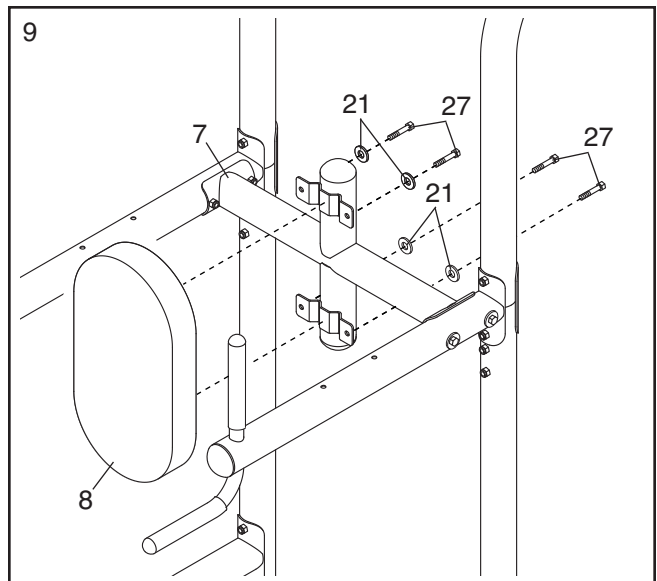

10. Attach an Arm Pad (6) to one of the Dip Arms (5) with two M6 x 73mm Screws (18).

**Repeat this step with the other Arm Pad (6).**

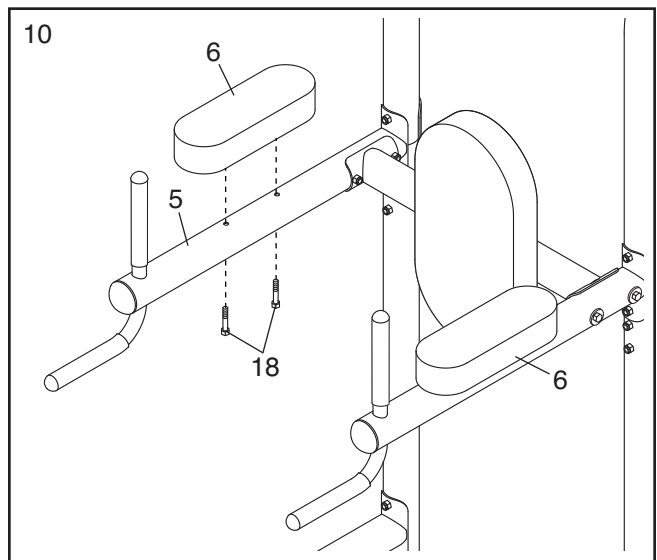

11. **Make sure that all parts have been properly tightened before the exercise rack is used.** Note: Some hardware may be left over after assembly is completed.

---

# EXERCISE GUIDELINES

## THE FOUR BASIC TYPES OF WORKOUTS

### Muscle Building

To increase the size and strength of your muscles, push them close to their maximum capacity. Your muscles will continually adapt and grow as you progressively increase the intensity of your exercise. You can adjust the intensity level of an individual exercise in two ways:

- by changing the amount of resistance used
- by changing the number of repetitions or sets performed. (A “repetition” is one complete cycle of an exercise, such as one sit-up. A “set” is a series of repetitions.)

The proper amount of resistance for each exercise depends upon the individual user. You must gauge your limits and select the amount of resistance that is right for you. Begin with 3 sets of 8 repetitions for each exercise you perform. Rest for 3 minutes after each set. When you can complete 3 sets of 12 repetitions without difficulty, increase the amount of resistance.

### Toning

You can tone your muscles by pushing them to a moderate percentage of their capacity. Select a moderate amount of resistance and increase the number of repetitions in each set. Complete as many sets of 15 to 20 repetitions as possible without discomfort. Rest for 1 minute after each set. Work your muscles by completing more sets rather than by using high amounts of resistance.

### Weight Loss

To lose weight, use a low amount of resistance and increase the number of repetitions in each set. Exercise for 20 to 30 minutes, resting for a maximum of 30 seconds between sets.

### Cross Training

Cross training is an efficient way to get a complete and well-balanced fitness program. An example of a balanced program follows:

- Plan strength training workouts on Monday, Wednesday, and Friday.
- Plan 20 to 30 minutes of aerobic exercise, such as running on a treadmill or riding on an elliptical exerciser or exercise cycle, on Tuesday and Thursday.
- Rest from both strength training and aerobic exercise for at least one full day each week to give your body time to regenerate.

The combination of strength training and aerobic exercise will reshape and strengthen your body, plus develop your heart and lungs.

## PERSONALIZING YOUR EXERCISE PROGRAM

Determining the appropriate length of time for each workout, and the numbers of repetitions and sets to complete, is an individual matter. Avoid overdoing it during the first few months of your exercise program. Progress at your own pace and be sensitive to your body’s signals. If you experience pain or dizziness while exercising, stop immediately and cool down. Find out what is wrong before continuing. Remember that adequate rest and a proper diet are important factors in any exercise program.

### WARMING UP

Begin each workout with 5 to 10 minutes of stretching and light exercise to warm up. Warming up prepares your body for more strenuous exercise by increasing circulation, raising your body temperature, and delivering more oxygen to your muscles.

### WORKING OUT

Each workout should include 6 to 10 different exercises. Select exercises for every major muscle group, emphasizing areas that you want to develop most. To give balance and variety to your workouts, vary the exercises from workout to workout.

Schedule your workouts for the time of day when your energy level is the highest. Each workout should be followed by at least one day of rest. Once you find the schedule that is right for you, stick with it.

### EXERCISE FORM

Maintaining proper form is an essential part of an effective exercise program. This requires moving through the full range of motion for each exercise, and moving only the appropriate parts of the body. Exercising in an uncontrolled way will leave you feeling exhausted. On the exercise guide accompanying this manual you will find photographs showing the correct form for several exercises, and a list of the muscles affected. See the muscle chart on the next page to find the names of the muscles.

The repetitions in each set should be performed smoothly and without pausing. The exertion stroke of each repetition should last about half as long as the return stroke. Proper breathing is important. Exhale during the exertion stroke of each repetition and inhale during the return stroke. Never hold your breath.

Rest for a short period of time after each set. The ideal resting periods are:

- Rest for three minutes after each set for a muscle building workout.
- Rest for one minute after each set for a toning workout.
- Rest for 30 seconds after each set for a weight loss workout.

Plan to spend the first couple of weeks familiarizing yourself with the equipment and learning the proper form for each exercise.

## COOLING DOWN

End each workout with 5 to 10 minutes of stretching. Include stretches for both your arms and legs. Move slowly as you stretch and do not bounce. Ease into each stretch gradually and go only as far as you can without strain. Stretching at the end of each workout is an effective way to increase flexibility.

## STAYING MOTIVATED

For motivation, keep a record of each workout. Write the date, the exercises performed, the resistance used, and the numbers of sets and repetitions completed. Record your weight and key body measurements at the end of every month. The key to achieving the greatest results is to make exercise a regular and enjoyable part of your everyday life.

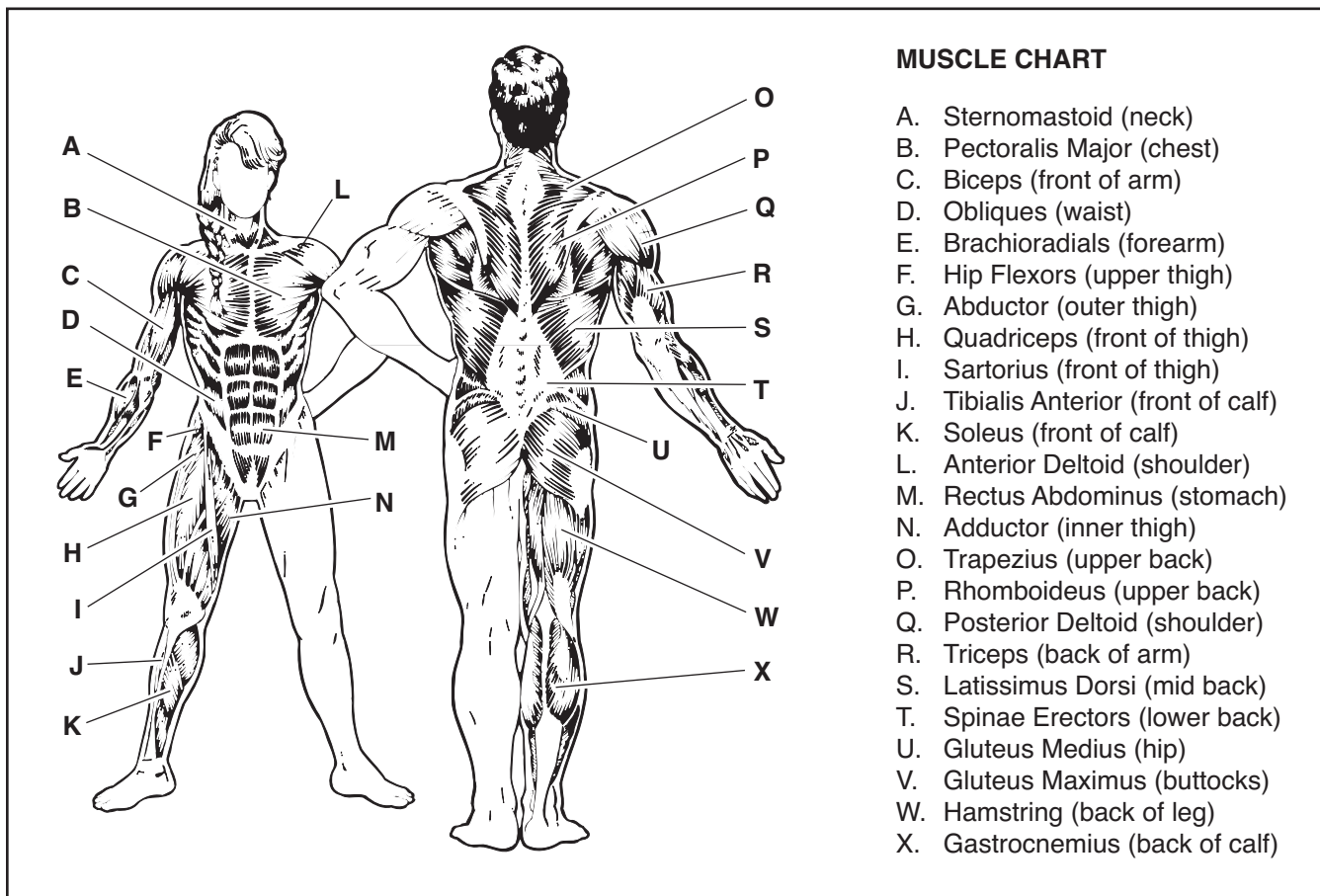

## EXERCISE LOG

Make copies of this page, and use the copies to schedule and record your strength and aerobic workouts. Scheduling and recording your workouts will help you to make exercise a regular and enjoyable part of your life.

### Strength

Date:

\_\_\_\_ / \_\_\_\_ / \_\_\_\_

Exercise	Lbs.	Sets	Reps	Exercise	Lbs.	Sets	Reps
1.				6.			
2.				7.			
3.				8.			
4.				9.			
5.				10.			

### Aerobic

Date:

\_\_\_\_ / \_\_\_\_ / \_\_\_\_

Exercise	Time	Distance	Speed

### Strength

Date:

\_\_\_\_ / \_\_\_\_ / \_\_\_\_

Exercise	Lbs.	Sets	Reps	Exercise	Lbs.	Sets	Reps
1.				6.			
2.				7.			
3.				8.			
4.				9.			
5.				10.			

### Aerobic

Date:

\_\_\_\_ / \_\_\_\_ / \_\_\_\_

Exercise	Time	Distance	Speed

### Strength

Date:

\_\_\_\_ / \_\_\_\_ / \_\_\_\_

Exercise	Lbs.	Sets	Reps	Exercise	Lbs.	Sets	Reps
1.				6.			
2.				7.			
3.				8.			
4.				9.			
5.				10.			

### Aerobic

Date:

\_\_\_\_ / \_\_\_\_ / \_\_\_\_

Exercise	Time	Distance	Speed

# PART LIST—Model No. GGBE0969.0

R0509A

Key No.	Qty.	Description	Key No.	Qty.	Description
1	2	Stabilizer	16	4	60mm Outer Cap
2	2	Upright Base	17	8	M8 x 75mm Bolt
3	2	Upright	18	4	M6 x 73mm Screw
4	2	Support	19	2	M10 x 50mm Screw
5	2	Dip Arm	20	8	M8 x 68mm Carriage Bolt
6	2	Arm Pad	21	4	M6 Washer
7	1	Top Crossbar	22	28	M8 Locknut
8	1	Backrest	23	12	M8 Washer
9	1	Pull-up Bar	24	4	M8 x 68mm Bolt
10	1	Bottom Crossbar	25	1	Foam Grip
11	8	Handgrip	26	2	M10 Washer
12	2	Rubber Cap	27	4	M6 x 16mm Screw
13	4	Support Plate	28	8	M8 x 77mm Bolt
14	8	25mm Cap	*	—	User's Manual
15	4	60mm Cap	*	—	Exercise Guide

Note: Specifications are subject to change without notice. For information about ordering replacement parts, please see the back cover of this manual. \*These parts are not illustrated.

# EXPLODED DRAWING—Model No. GGBE0969.0

R0509A

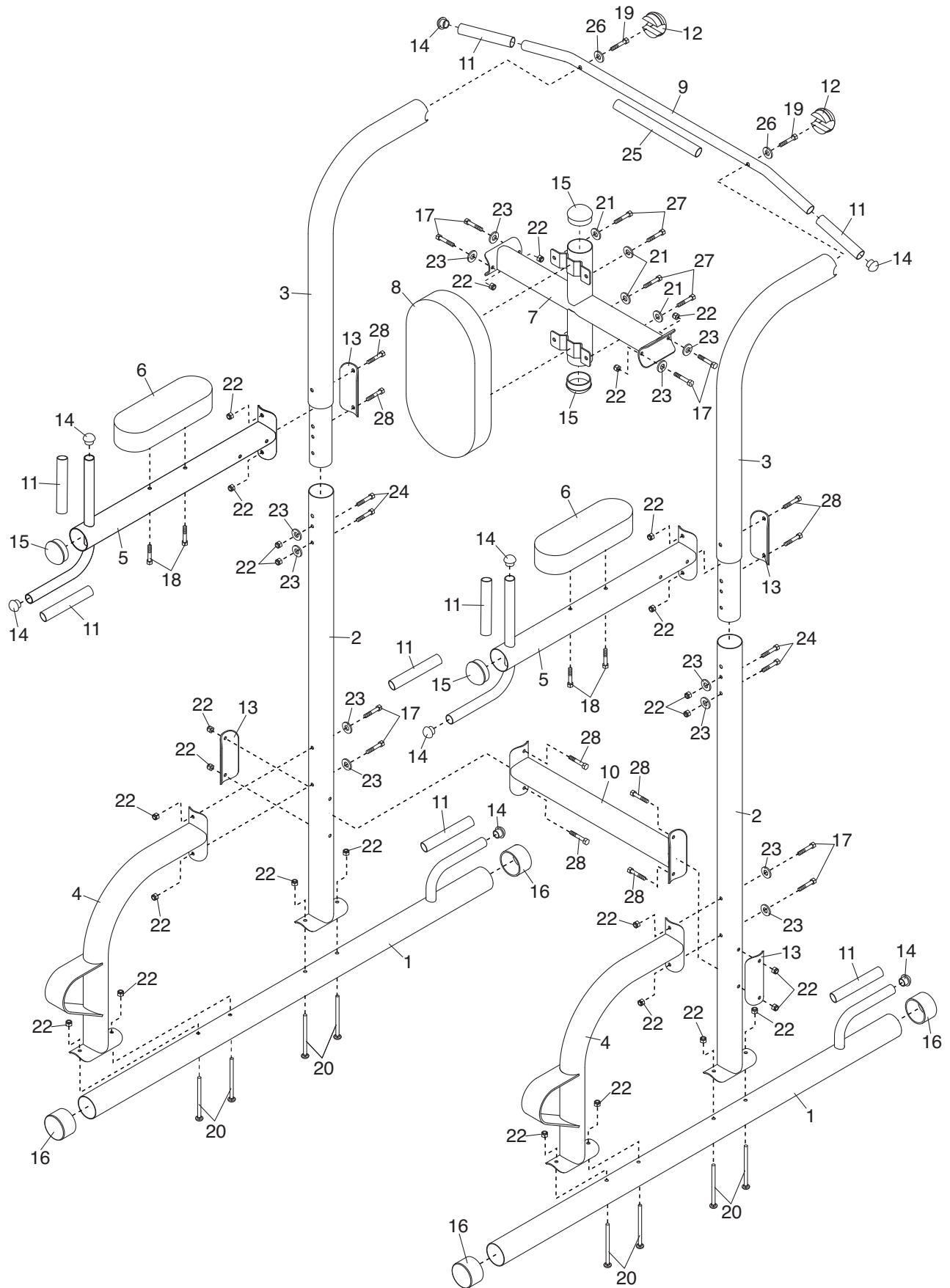

---

# ORDERING REPLACEMENT PARTS

To order replacement parts, please see the front cover of this manual. To help us assist you, be prepared to provide the following information when contacting us:

- the model number and serial number of the product (see the front cover of the manual)
- the name of the product (see the front cover of this manual)
- the key number and description of the part(s) (see the PART LIST and the EXPLODED DRAWING near the end of this manual)

## LIMITED WARRANTY

**IMPORTANT: You must register this product within 30 days of the purchase date to avoid added fees for service needed under warranty. Go to [www.workoutwarehouse.com/registration](http://www.workoutwarehouse.com/registration).**

ICON Health & Fitness, Inc. (ICON) warrants this product to be free from defects in workmanship and material, under normal use and service conditions. Parts and labor are warranted for ninety (90) days from the date of purchase.

This warranty extends only to the original purchaser. ICON's obligation under this warranty is limited to repairing or replacing, at ICON's option, the product through one of its authorized service centers. All repairs for which warranty claims are made must be preauthorized by ICON. If the product is shipped to a service center, freight charges to and from the service center will be the customer's responsibility. For replacement parts shipped while the product is under warranty, the customer will be responsible for a minimal handling charge. For in-home service, the customer will be responsible for a minimal trip charge. This warranty does not extend to any damage to a product caused by or attributable to freight damage, abuse, misuse, improper or abnormal usage, or repairs not provided by an ICON authorized service center; to products used for commercial or rental purposes or as store display models; or to products transported or purchased outside the US. No other warranty beyond that specifically set forth above is authorized by ICON.

ICON is not responsible or liable for indirect, special, or consequential damages arising out of or in connection with the use or performance of the product; damages with respect to any economic loss, loss of property, loss of revenues or profits, loss of enjoyment or use, or costs of removal or installation; or other consequential damages of whatsoever nature. Some states do not allow the exclusion or limitation of incidental or consequential damages. Accordingly, the above limitation may not apply to you.

The warranty extended hereunder is in lieu of any and all other warranties, and any implied warranties of merchantability or fitness for a particular purpose are limited in their scope and duration to the terms set forth herein. Some states do not allow limitations on how long an implied warranty lasts. Accordingly, the above limitation may not apply to you.

This warranty gives you specific legal rights. You may also have other rights that vary from state to state.

**ICON Health & Fitness, Inc., 1500 S. 1000 W., Logan, UT 84321-9813**