

Workbench Series



Warning: Excessive weight hazard!

Use two or more people to move, assemble or install workbench.

Failure to do so can result in back or other injury.

For assistance, call 1.877.306.8930; for UK 0800.031.4069; e-mail at info@newageproducts.com

Parts List

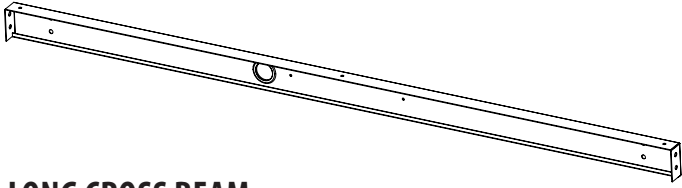

LONG CROSS BEAM

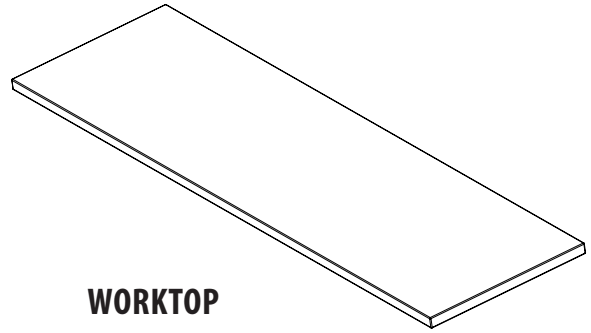

WORKTOP



LONG SUPPORT BEAM FOR 96" BENCH

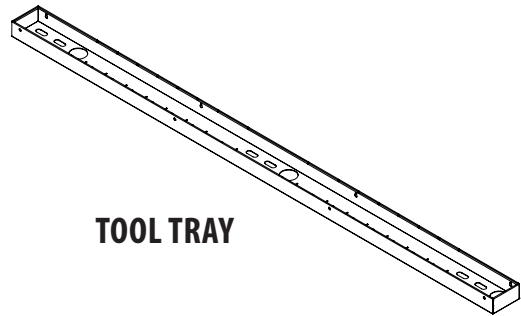

TOOL TRAY

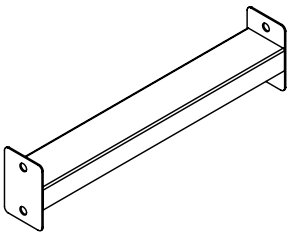

SHORT SUPPORT BEAM

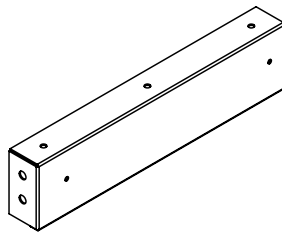

SHORT CROSS BEAM

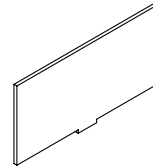

TOOL TRAY DIVIDERS

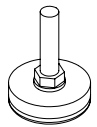

ADJUSTABLE FEET



LEG (A)

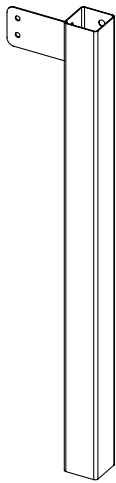

LEG (B)

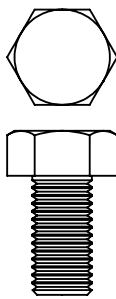

**9/16" x 5/8"
HEX BOLTS**

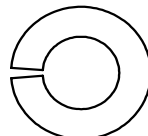

**9/16" LOCK
WASHERS**

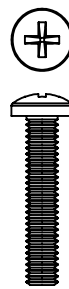

**#8-32 x 7/8"
BOLTS**



**#8-32 LOCK
WASHERS
AND NUTS**



**#8-32 x 3/4"
SCREWS**

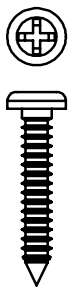

**#8-32 x 1"
SCREWS**

Tools Needed



1 x 9/16" Socket driver wrench

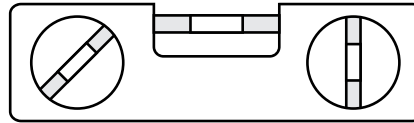

1 x 12" Magnetic Leveler

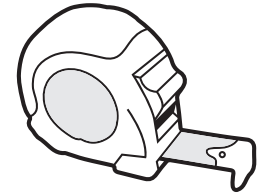

1 x Tape Measure

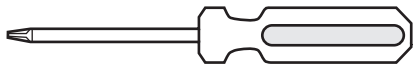

1 x #2 Phillips Bit Screwdriver

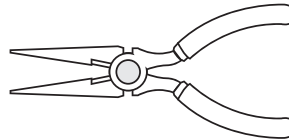

1 x Pliers

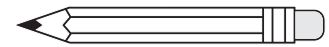

1 x Pencil

Parts and Hardware Supplied

Parts	48" Workbench	72" Workbench	96" Workbench
Threaded Adjustable Foot	4	4	4
Long Cross Beam	2	2	2
Long Support Beam	0	0	1
Short Cross Beam	2	2	2
Short Support Beam	2	2	2
Leg (A)	2	2	2
Leg (B)	2	2	2
9/16" x 5/8" L Hex Bolts	32	32	36
9/16" Lock Washers	32	32	36
#8 x 3/4" Wood Screws	12	12	12
#8-32 x 7/8" Bolts	2	2	2
#8 Lock Washers	2	2	2
#8-32 Nuts	2	2	2
9/32" Mini Wrench	1	1	1
#8 x 1" Wood Screws	4	4	4
Tool Tray	1	1	1
Tool Tray Dividers	4	6	8
Worktop	1	1	1
Power bar	1	1	1
Tablet Stand	1	1	1

Rated Weight Capacity

	Evenly Distributed Weight Capacity (lbs)	Tray Weight Capacity (lbs)
48" Workbench	2000	40
72" Workbench	2000	40
96" Workbench	2000	40

WARNING:
Mechanical is Max load. 2000lb.
Electrical limitations is Max 15A.

Assemble The Frame

1. Select one Leg (A) and one Leg (B) and lay them opposite one another on the floor with the leg brackets positioned on the outside of the two legs, and facing in the same direction. See Figure 1.
2. Select one Short Cross Beam, and one Short Support Beam, and bolt the side frame assembly together with the supplied 9/16" hex bolts and lock washers. See Figure 1.

Note: Legs are shown being assembled upside down, as this will be easiest for assembly and installing the top.

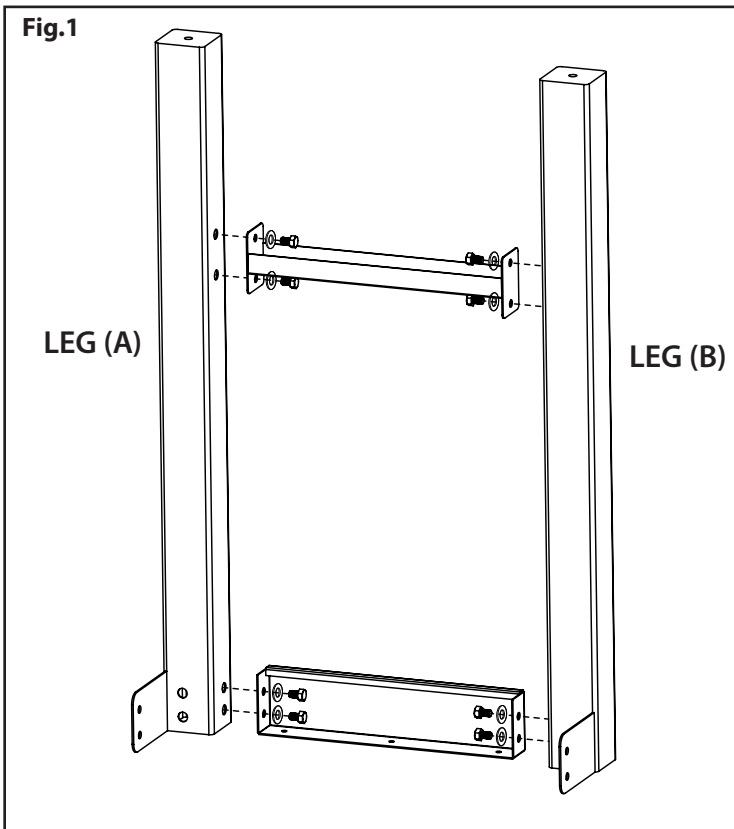

3. Repeat steps 1 and 2 for assembling the opposite side frame assembly.
4. Secure the two Long Cross Beams to the post of the two legs with the supplied 9/16" hex bolts and lock washers. See Figure 2

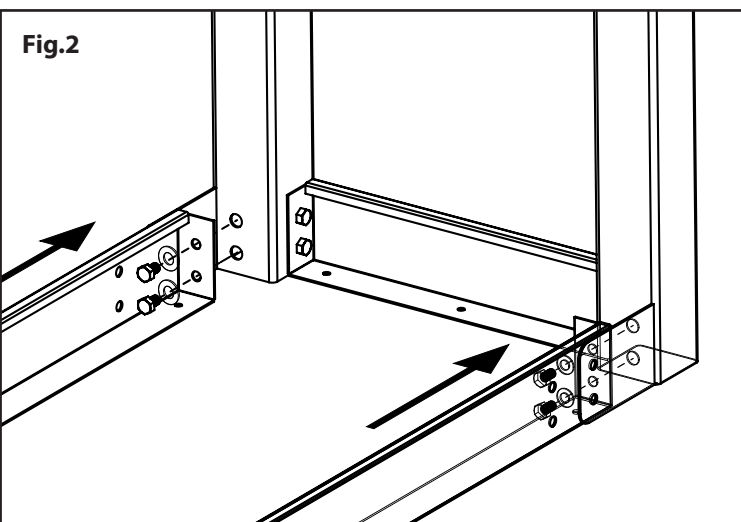

5. Repeat Step 4 for the opposite side to secure the two side frame assemblies to the Long Cross Beams.
6. Secure the leg brackets to the Long Cross Beams with the supplied 9/16" hex bolts and lock washers. See Figure 3.
7. Repeat Step 6 for the remaining leg brackets.

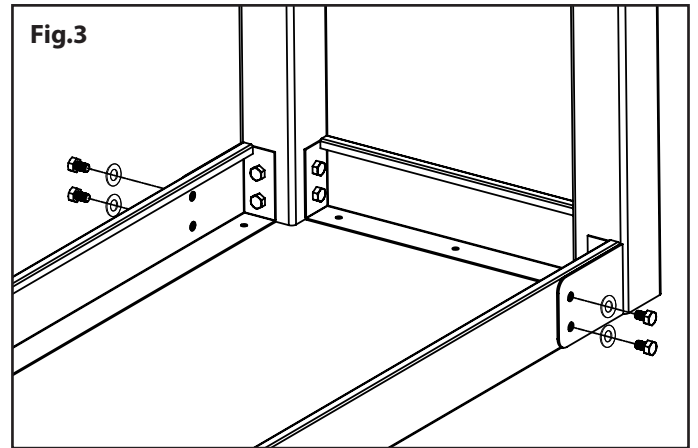

8. Place the workbench top upside down on a protected surface and mark the top with a pencil 2" in from the sides, 1-9/16" in from the front edge, and 3/16" in from the back edge as seen in Figure 4. This boundary represents the correct mounting location for the steel workbench frame.

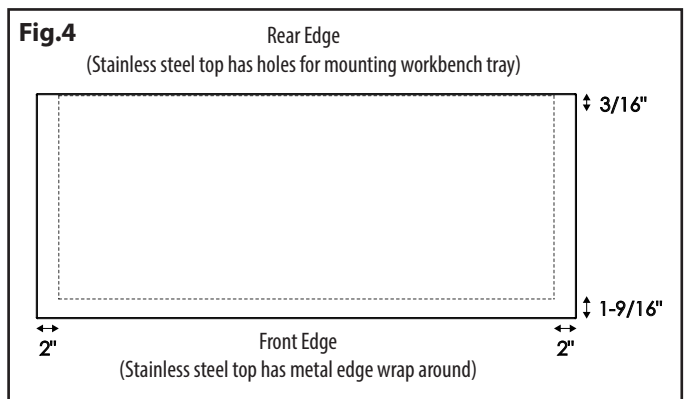

9. Place the frame within the marked boundary and attach the top with the supplied #8 x 5/8" wood screws in the 12 locations provided. For bamboo top: Drill 1/16" pilot holes and install screws. See Figure 5.

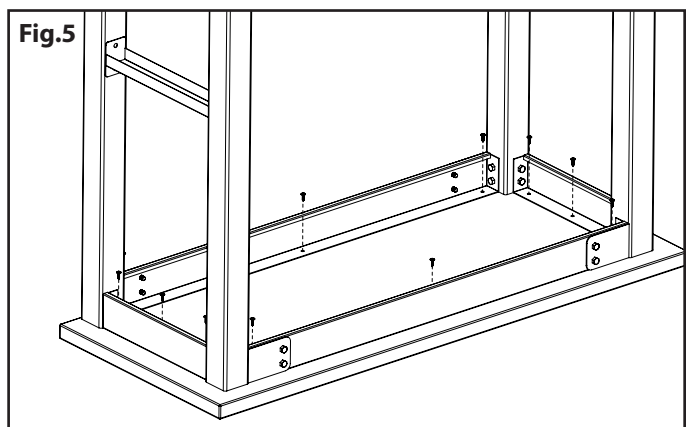

Mounting The Tool Tray

1. For Stainless Steel Top:

Install (4) #8 x 1" screws in the locator holes along the edge of the worktop, 3/4 of the way in.

For Bamboo Top:

Place tray flush with the top of worktop (Figure 1) and use the tray as a guide to mark the center of the top of the keyholes for the 4 screw locations along the edge. (Figure 2)

Drill 1/16" pilot hole and install screws 3/4 of the way in.

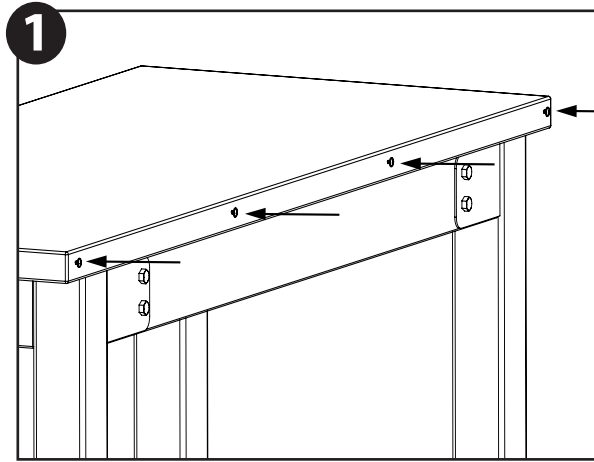

Installing Bamboo Top Tray

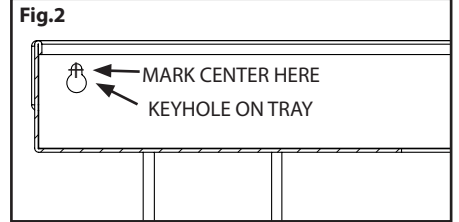
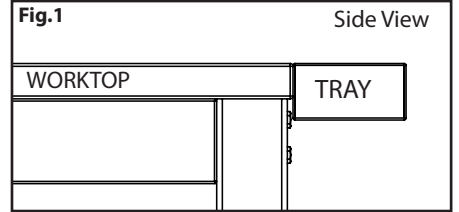

2. Slide the keyholes on the side of the tray over the heads of the screws.

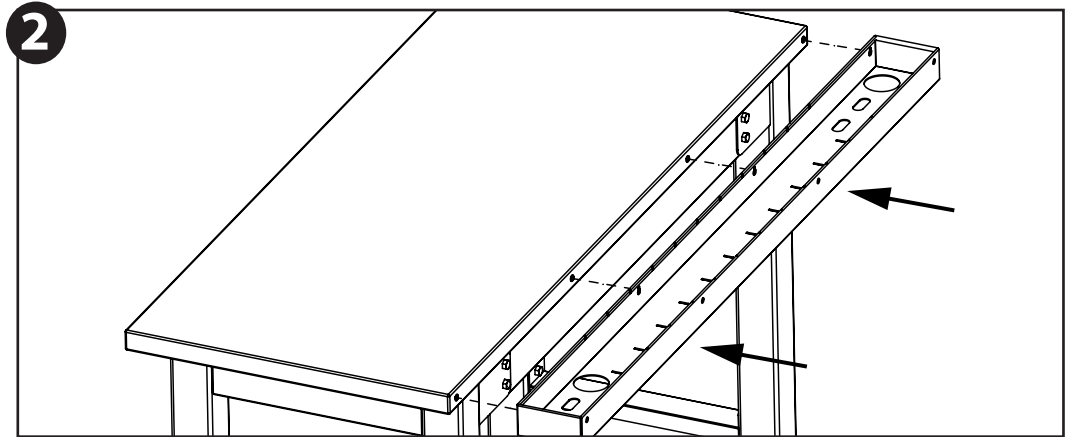

3. Slide the tray down over the screws and tighten with a screwdriver to secure the tray to the workbench.

Insert screwdriver through the access holes for easy installation.

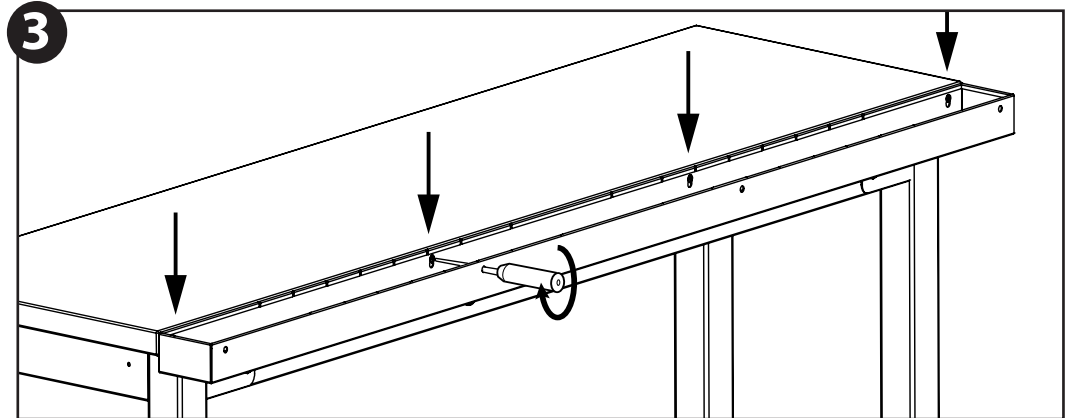

4. Thread in the leveling feet and adjust as needed for leveling the workbench.

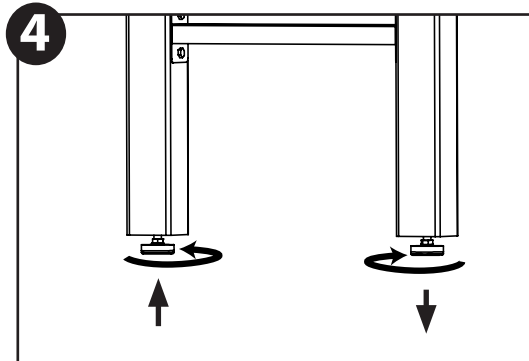

5. Insert tray dividers in the desired locations.

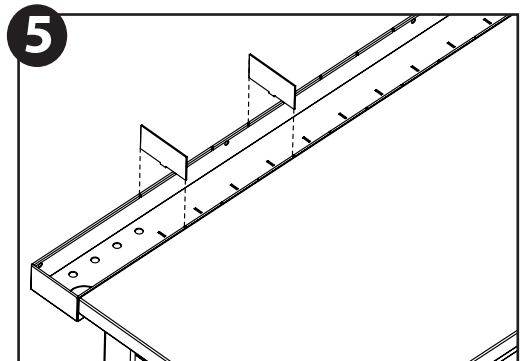

Mounting Power Bar

1. Insert the two #8-32 bolts into the slots on the back of the power bar. Secure the screws in the lower gap towards the cord.

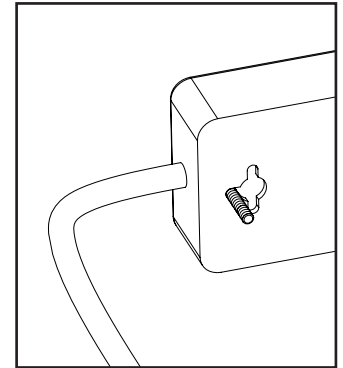
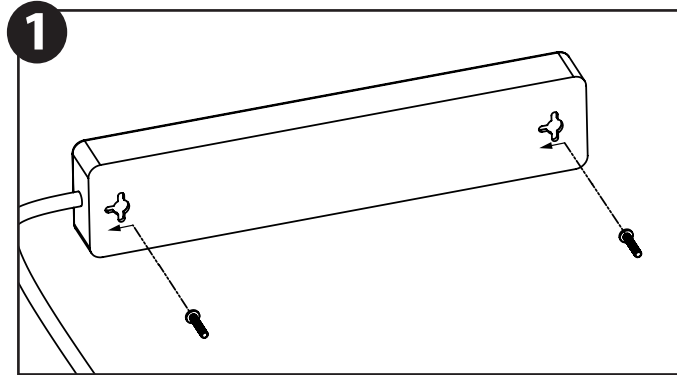

2. Install the power bar onto the workbench by inserting the two screws through the corresponding holes on the front, or sides of the workbench.

If installing the power bar on the front of the workbench you can feed the cord for the power bar through the rubber grommets on the front and back of the workbench.

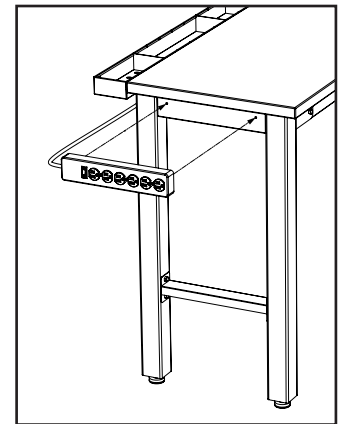
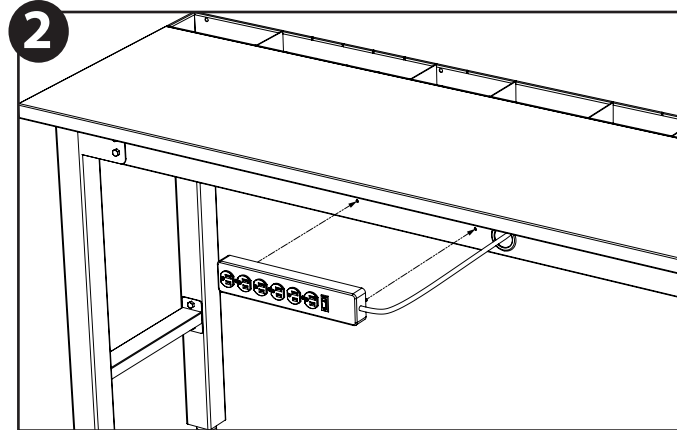

3. Using the supplied 9/32" wrench, fix the power bar in place with the provided lock washers and #8-32 nuts.

Note: It may be necessary to grip the ends of the bolt with a pair of pliers to prevent the bolt from spinning while tightening.

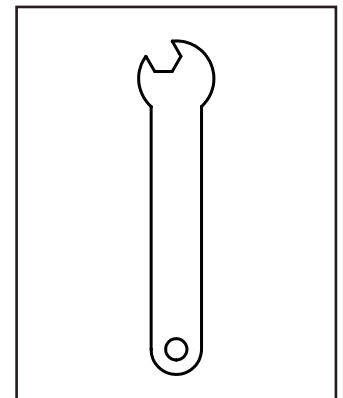
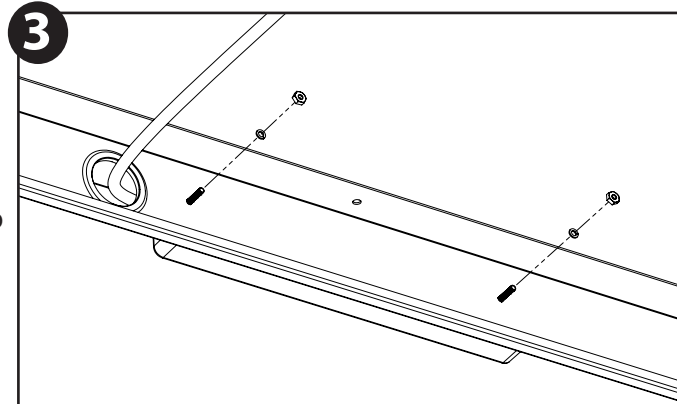

INSTALL TABLET STAND (OPTIONAL):

1. Angle the tablet stand and insert through slots located on the workbench tray and allow the hooks to engage under the workbench tray.

Use the tablet stand with your favorite device.

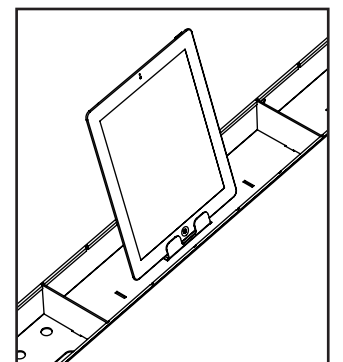
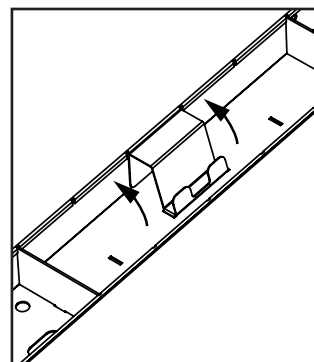
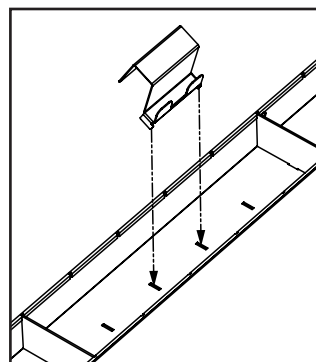

Note: Ensure your device is stable inside the stand. NewAge products will not be responsible for any damage caused to your device as a result accidental droppage or use of this stand.

Thank you for purchasing from NewAge Product.

NEWAGE PRODUCTS INC. WELDED WORKBENCH 10 YEAR LIMITED MANUFACTURER WARRANTY



When this product is installed, operated and maintained according to the instructions attached to or furnished with the product, NewAge Products Inc. will replace the defective product or parts if the part fails as a result of defective materials or workmanship for a period of ten years from the date of purchase.

NEWAGE PRODUCTS INC. WILL NOT PAY FOR:

1. Service calls to correct the installation of any NewAge products or to instruct you how to use or install them.
 2. Damage resulting from improper handling or shipping of products, or products damaged by accident, misuse, abuse, fire, flood, improper installation, acts of God, neglect, corrosion, modification or mishandling.
 3. Products damaged by improperly loading beyond the specified maximum weight capacity outlined in the instructions provided with the product.
 4. Repairs or replacement when your product is used in other than normal, single-family household use, such as a commercial environment, or handled in any way inconsistent with the installation instructions included with the product.
 5. Cosmetic damage, including scratches, dings, dents or cracks in paint that do not affect the structural or functional capability of the product.
 6. Surfaces damaged due to chemical interaction resulting in corrosion of paint or metal.
 7. Replacement parts for NewAge products outside Canada, United States, or United Kingdom.
 8. Replacement keys or locking mechanisms.
 9. Loss of product contents due to theft, fire, flood, accident or acts of God.
 10. Shipping or freight fees to deliver replacement products or to return defective products.
 11. Any labor costs during the limited warranty period.
-

DISCLAIMER OF IMPLIED WARRANTIES; LIMITATION OF REMEDIES

IMPLIED WARRANTIES, INCLUDING TO THE EXTENT APPLICABLE WARRANTIES OF MERCHANTABILITY OR FITNESS FOR A PARTICULAR PURPOSE, ARE EXCLUDED TO THE EXTENT LEGALLY PERMISSIBLE. ANY IMPLIED WARRANTIES THAT MAY BE IMPOSED BY LAW ARE LIMITED TO ONE YEAR, OR THE SHORTEST PERIOD ALLOWED BY LAW. SOME STATES AND PROVINCES DO NOT ALLOW LIMITATIONS OR EXCLUSIONS ON HOW LONG AN IMPLIED WARRANTY OF MERCHANTABILITY OR FITNESS LASTS, SO THE ABOVE LIMITATIONS OR EXCLUSIONS MAY NOT APPLY TO YOU. THIS WARRANTY GIVES YOU SPECIFIC LEGAL RIGHTS, AND YOU MAY ALSO HAVE OTHER RIGHTS WHICH VARY FROM STATE TO STATE OR PROVINCE TO PROVINCE



Need more information? Try WWW.NEWAGEPRODUCTS.COM

Call At **1.877.306.8930**; for UK **0800.031.4069**

Or e-mail at info@newageproducts.com

NewAge Products Inc.
201 Chrislea Road, Vaughan, ON
L4L 8N6, Canada