

# CSCI ASSEMBLY INSTRUCTIONS

## FOR CFV0092/ CFV0093 Saddle Stool

Read instructions carefully. Remove all wrapping material, staples and packing straps from the carton. Check Hardware and Furniture Parts. Be sure you have all parts before you start assembling. Place all wooden furniture parts on a clean and flat soft surface, such as carpet or rug to prevent from being scratched.

**CAUTIONS:** (1) DO NOT FULLY-TIGHTEN THE WOOD SCREWS INITIALLY UNTIL ALL THE WOOD PARTS ASSEMBLED READY.

(TO AVOID CAUSING DAMAGES TO THE THREAD, DO NOT OVER-TIGHTEN THE WOOD SCREWS.)

(2) KEEP ALL HARDWARE PARTS OUT OF CHILDREN.

### PART LIST

NO	COMPONENT	QTY
A	LEG (LEFT)	2
B	LEG (RIGHT)	2
C	SEAT	1
D	SHORT CROSSBAR	2
E	MEDIUM CROSSBAR	2
F	LONG CROSSBAR	2

### HARDWARE LIST

NO	DESCRIPTION	QTY
G	WOOD SCREW	16
H	GLUE	1

\*" WAIT UNTIL GLUE IS DRY ".  
At least ( 24 hours )  
Your chair is ready for use.

#### REMARK

- 1.) Please tighten screws periodically
- 2.) Check tightness of all screw every 6-8 weeks.

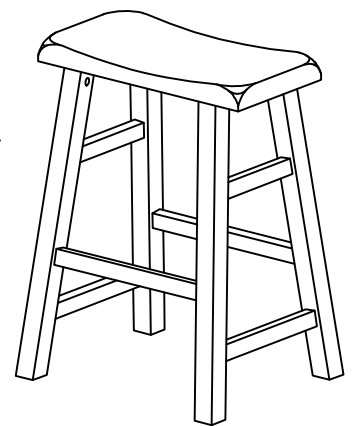

COMPLETE ASSEMBLY

**Step 1:** Apply glue (H) into the circled holes of leg (A), and leg (B) as shown. Connect tenon of short crossbar (D) and medium crossbar (E) to leg (A) and leg (B).

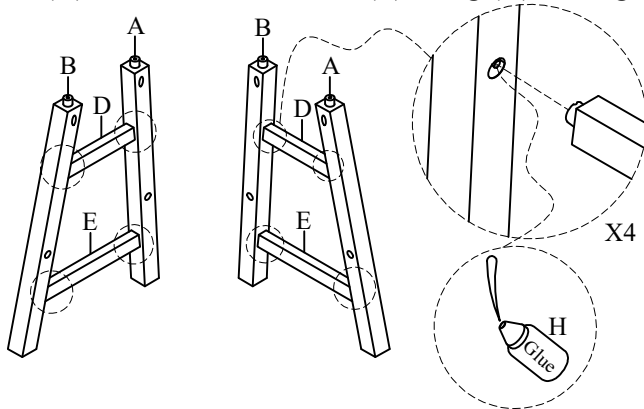

**Step 2:** Apply glue (H) for stronger connection between long crossbar (F) to leg frame of step 1.

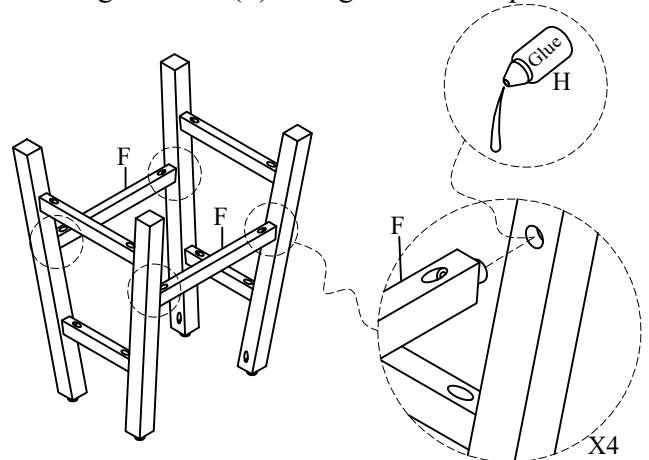

**Step 3:** Apply glue (H) into the holes of the seat (C). Connect the tenon of leg (A) and leg (B) to seat (C).

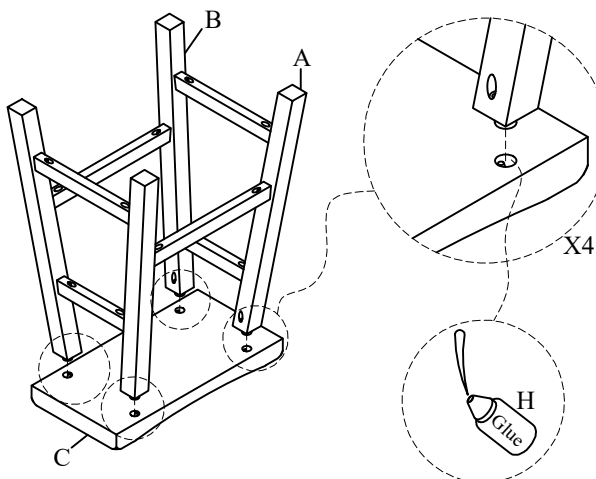

**Step 4:** Using wood screws (G) for available holes on these rails. Tighten with a phillips head screw driver (not included).

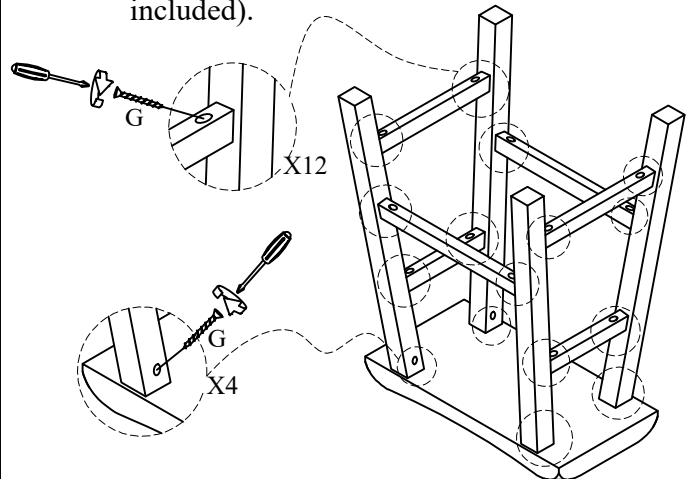

In case you need any extra parts, please feel free to contact us directly instead of returning your order. Feel free to email [service@ehemco.com](mailto:service@ehemco.com) or call 847-2899955 and we will be more than happy to help you within a business day.