

Assembly Instruction

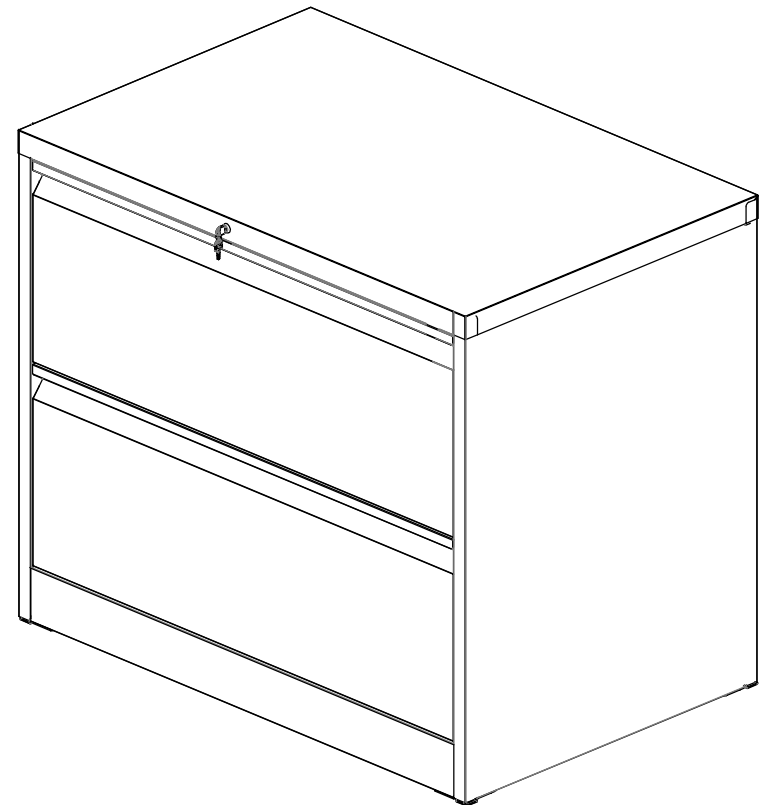

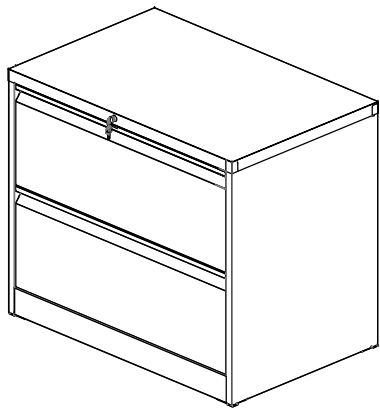

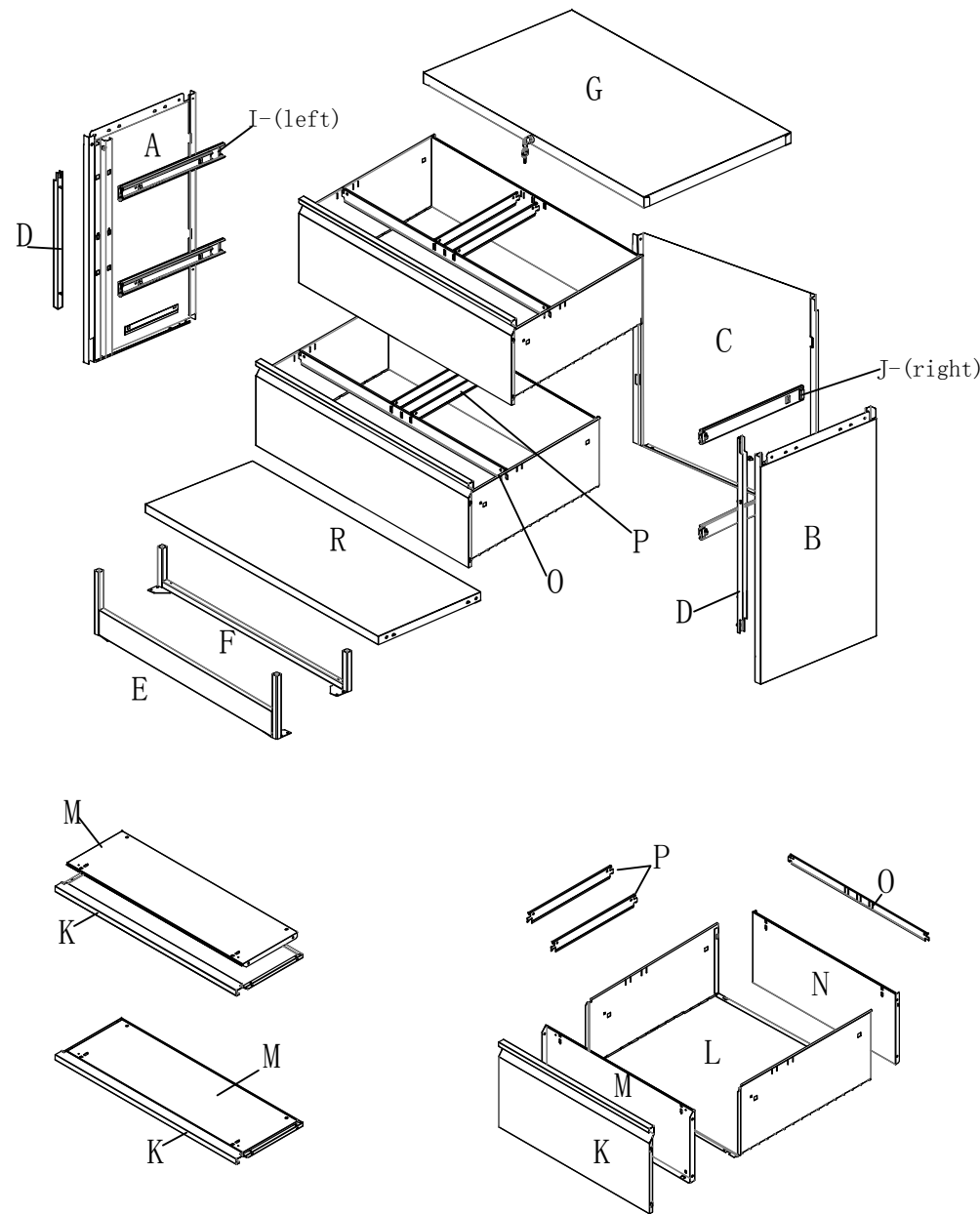



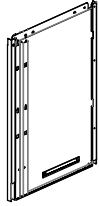
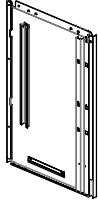
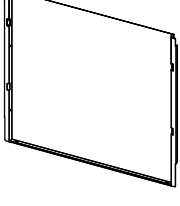

Drawers Cabinet

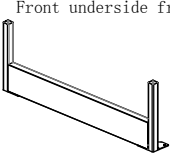
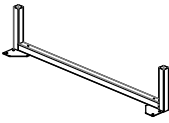
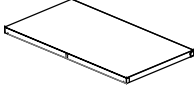



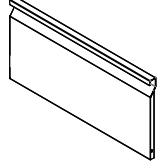
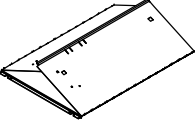
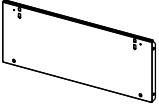
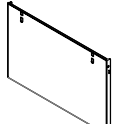
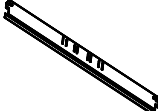

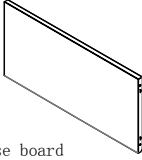

Part list:

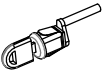
A Left side panel  1 (PC)	B Right side panel  1 (PC)	C Back board  1 (PC)	D Lock bar  2 (PCS)
E Front underside frame  1 (PC)	F Rear underside frame  1 (PC)	G Top board  1 (PC)	H Fall-prevention bar  1 (PC)
I-(left) Left drawer runner  2 (PCS)	J-(right) Right drawer runner  2 (PCS)	K Drawer face panel  2 (PCS)	L Drawer body  2 (PCS)
M Front guard panel  2 (PCS)	N Rear guard panel  2 (PCS)	O Horizontal hook rail  2 (PCS)	P Vertical hook rail  4 (PCS)
Q Lock mechanism housing bar  1 (PC)	R Base board  1 (PC)		

Hardware list:

a  Lock 1 (PC)	b  Floor protector 4 (PCS)	c  Top board anti-fall buckle 2 (PCS)	d  Phillips screwdriver 1 (PC)	e  Self-tapping screw φ4*12mm 14 (PCS)
--	--	---	--	---

Please note: before assembly, please ensure each of the above items are present and have the correct item number.

*H, Q doesn't appear in the above image. H is showed in Page 1. Q is showed in Page 5

Step 1 Assemble fall-prevention bar (H)

As shown in the picture, attach H to the groove in the right-side panel (B), adjust the top and bottom interval to around 0.39inch.

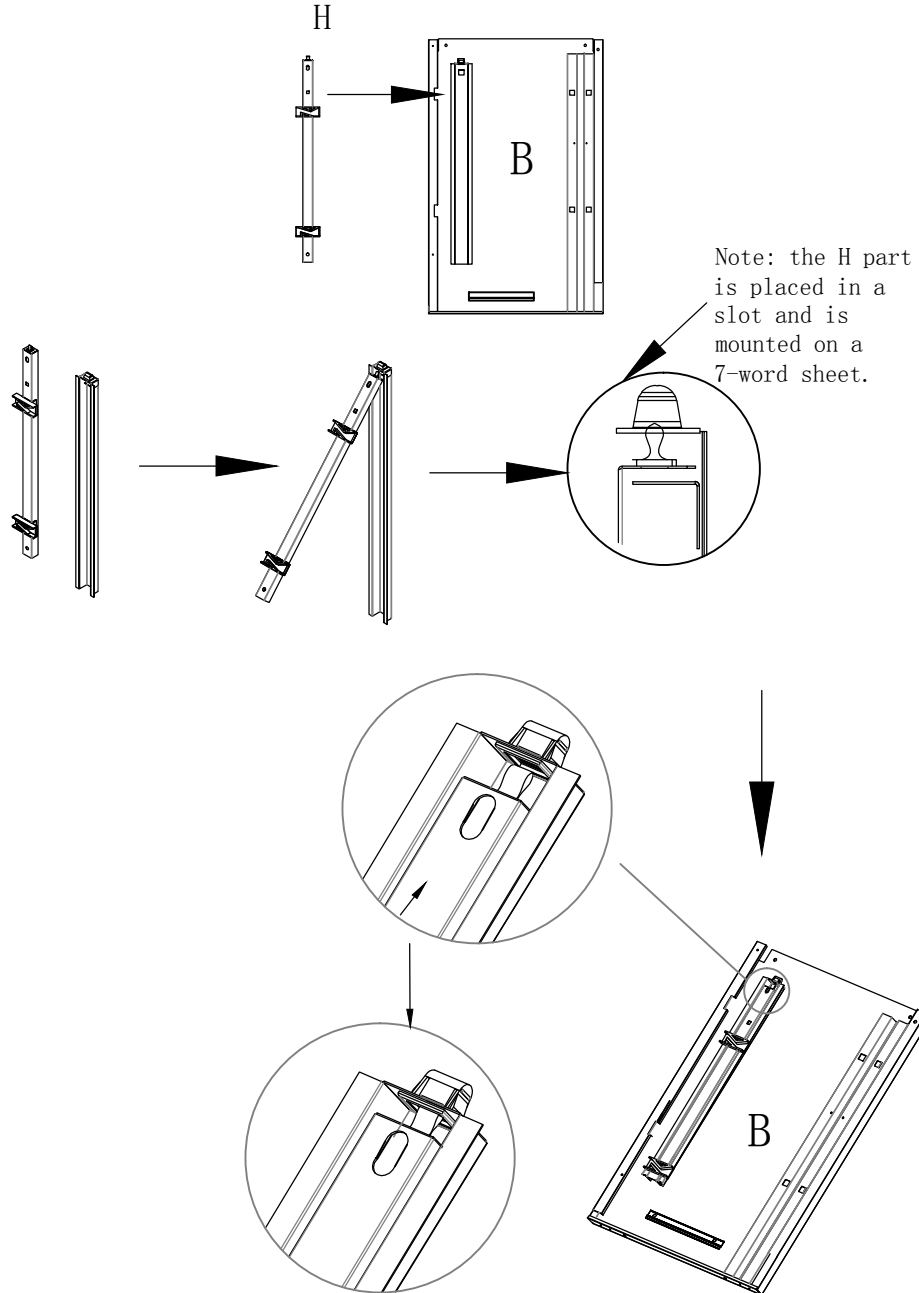

Step 2 Assemble Body

Stand the unit on the front and rear underside frames (E and F). Insert the left-side board (A) and right-side board (B) into E and F separately. Next, attach the backboard (C). Insert 5 self-tapping screws (e) into the appropriate holes, as directed by lines shown in the picture.

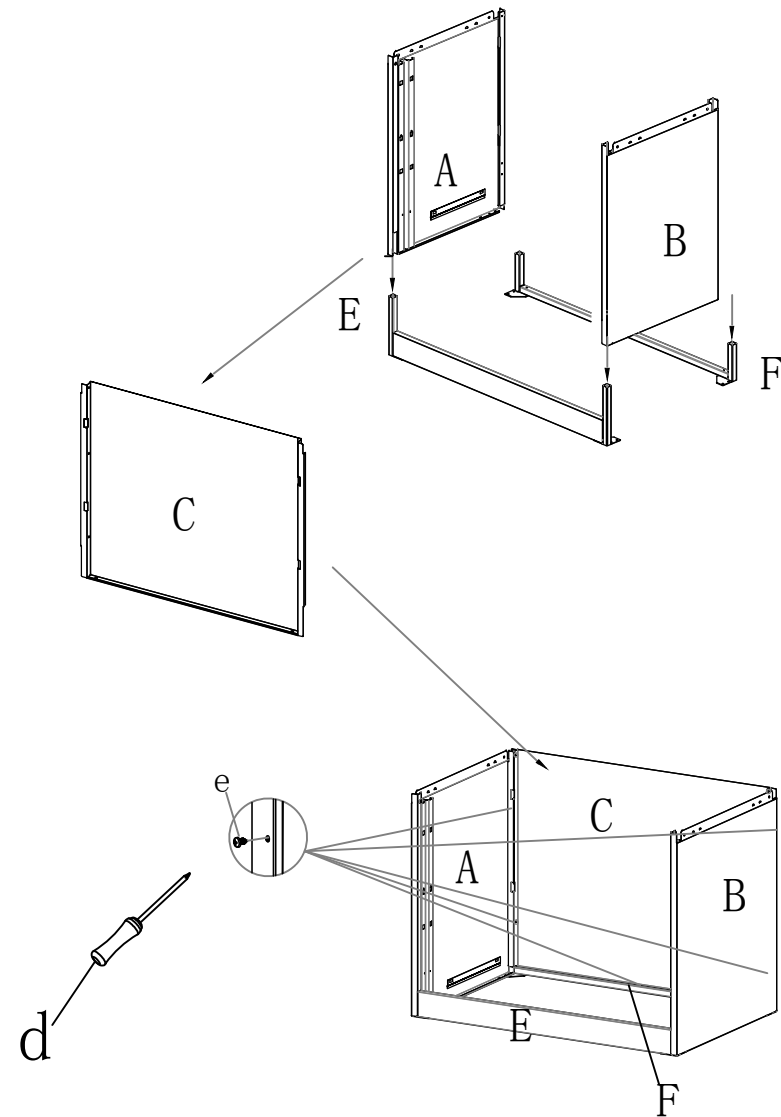

Step 3

Connect the body

Lay the unit down, with the backboard (C) face down. Use a screwdriver (not included) to assemble eight self-tapping screws (e), two in each corner.

Then, insert 4 rubber floor protectors (b) into the corresponding 4 square holes in each corner of the base.

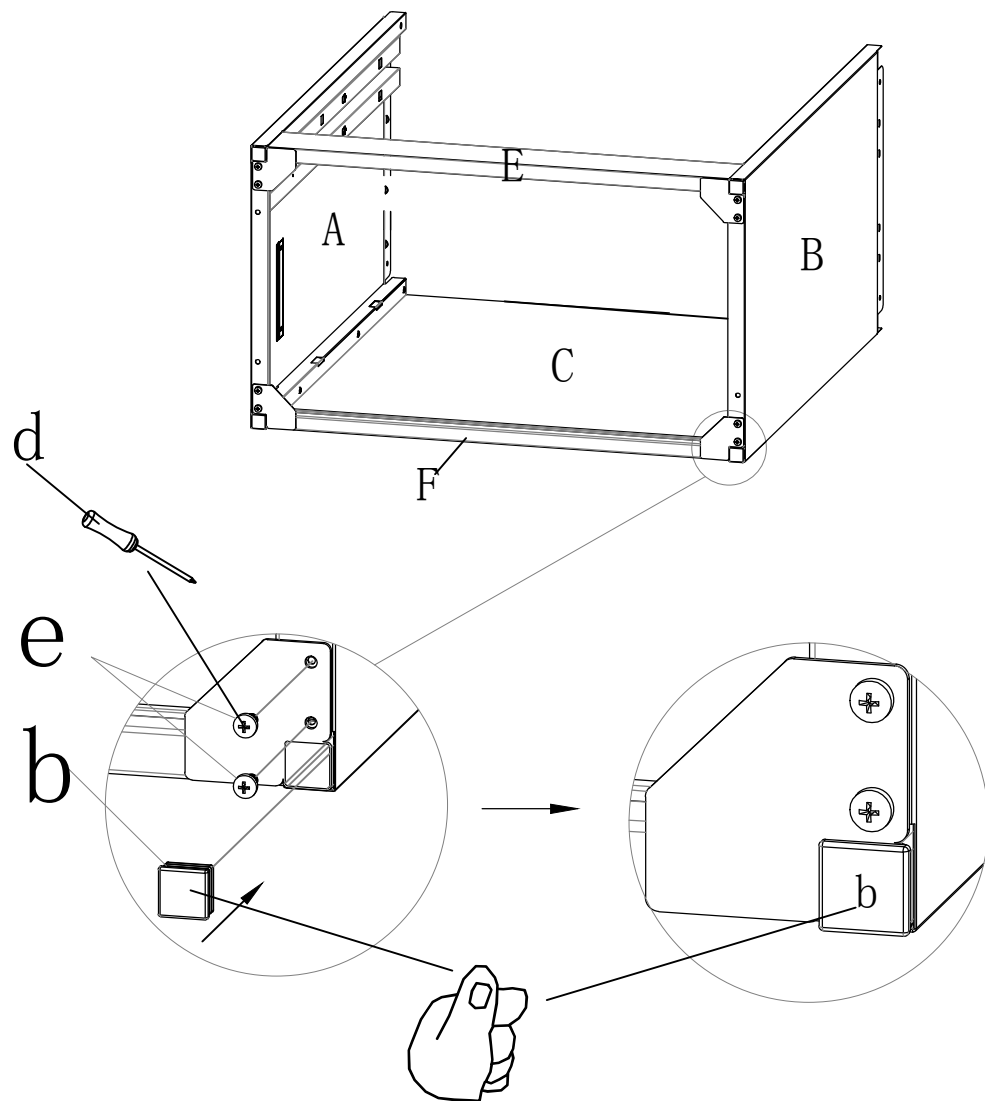

Step 4

Assemble the stick c

Put 2 top board anti-fall buckles (c) in the appropriate two holes at the front corners of each sideboard, as shown above.

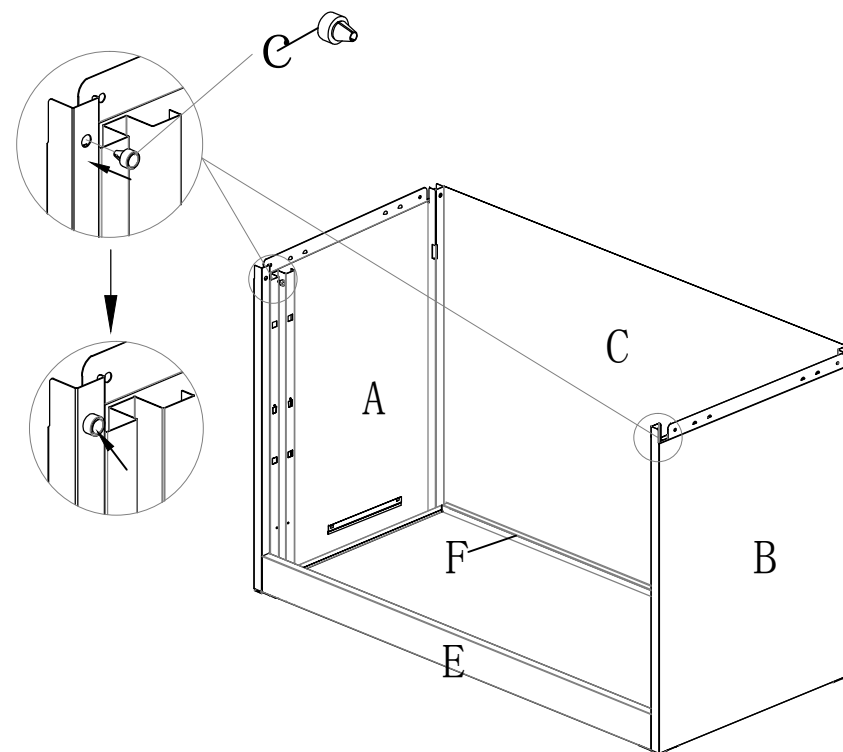

Step 5

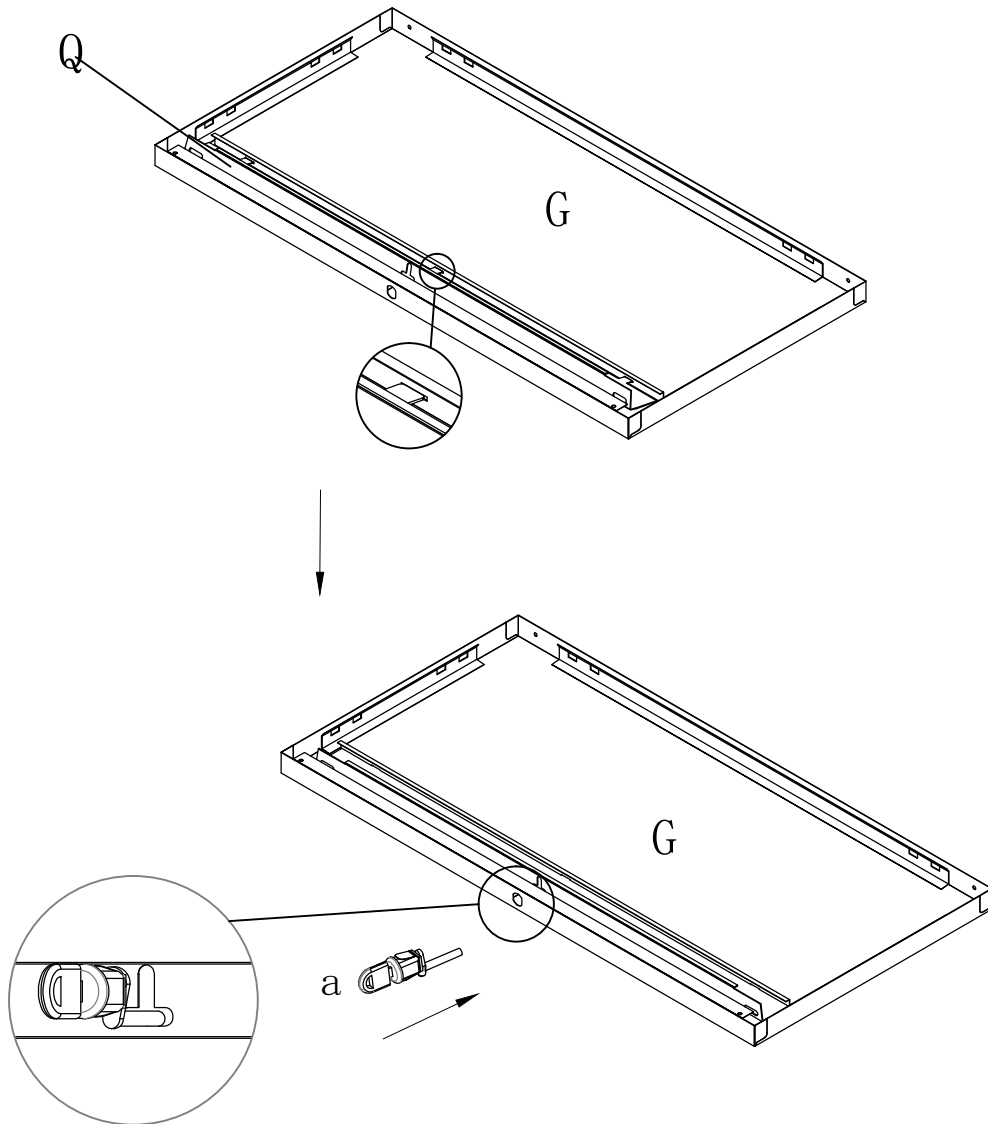

Assemble the lock mechanism housing bar (Q)
Put the lock mechanism housing bar (Q) against the top board (G). Insert the three bulges into the three holes on top board (G) to reinforce and, lastly, attach the lock a.

Step 6

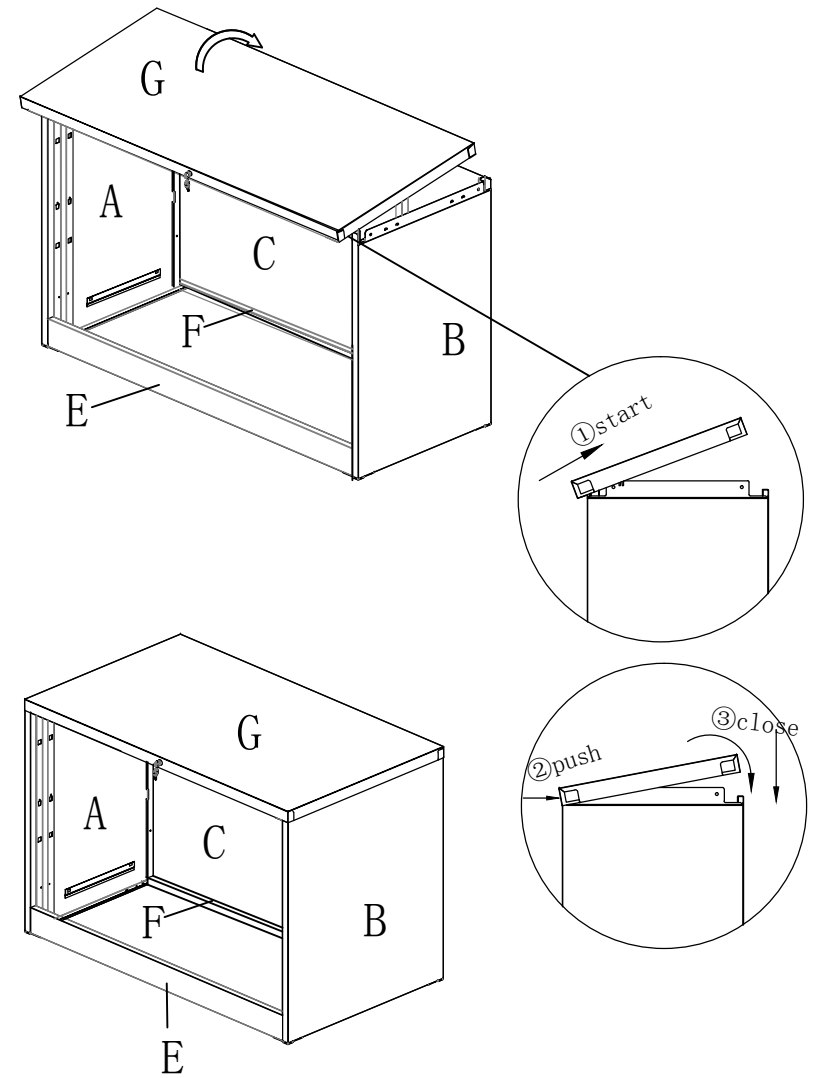

Assemble the top board (G)
Angle the top board (G) to install, so that the board edge is inserted under the buckle (C) and then lowered into place.

Step 7 Assemble baseboard (R) and lock bar (D)

Note the support clips on either side, ensuring that the board can be secured in the clips.

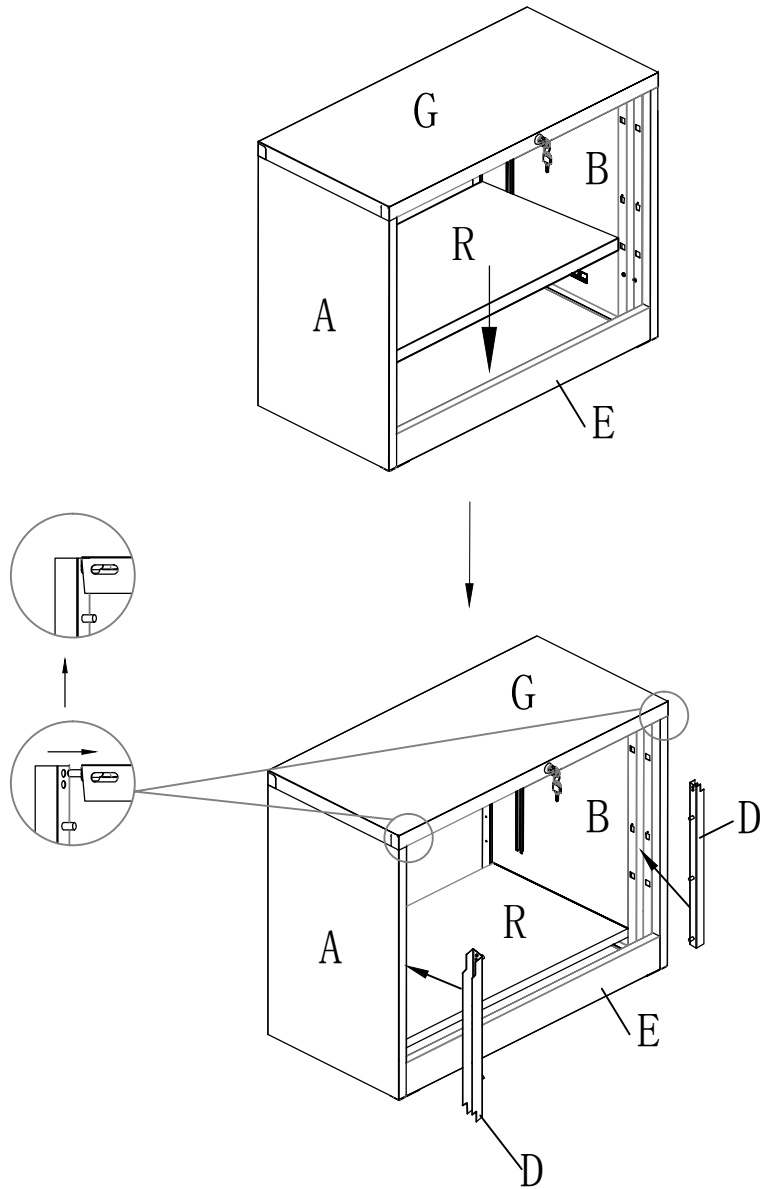

Then, install the lock bar (D). The two holes on the lock bar (D) are to be faced up, with the first hole aligned with the buckle of the lock mechanism housing bar (Q).

Step 8

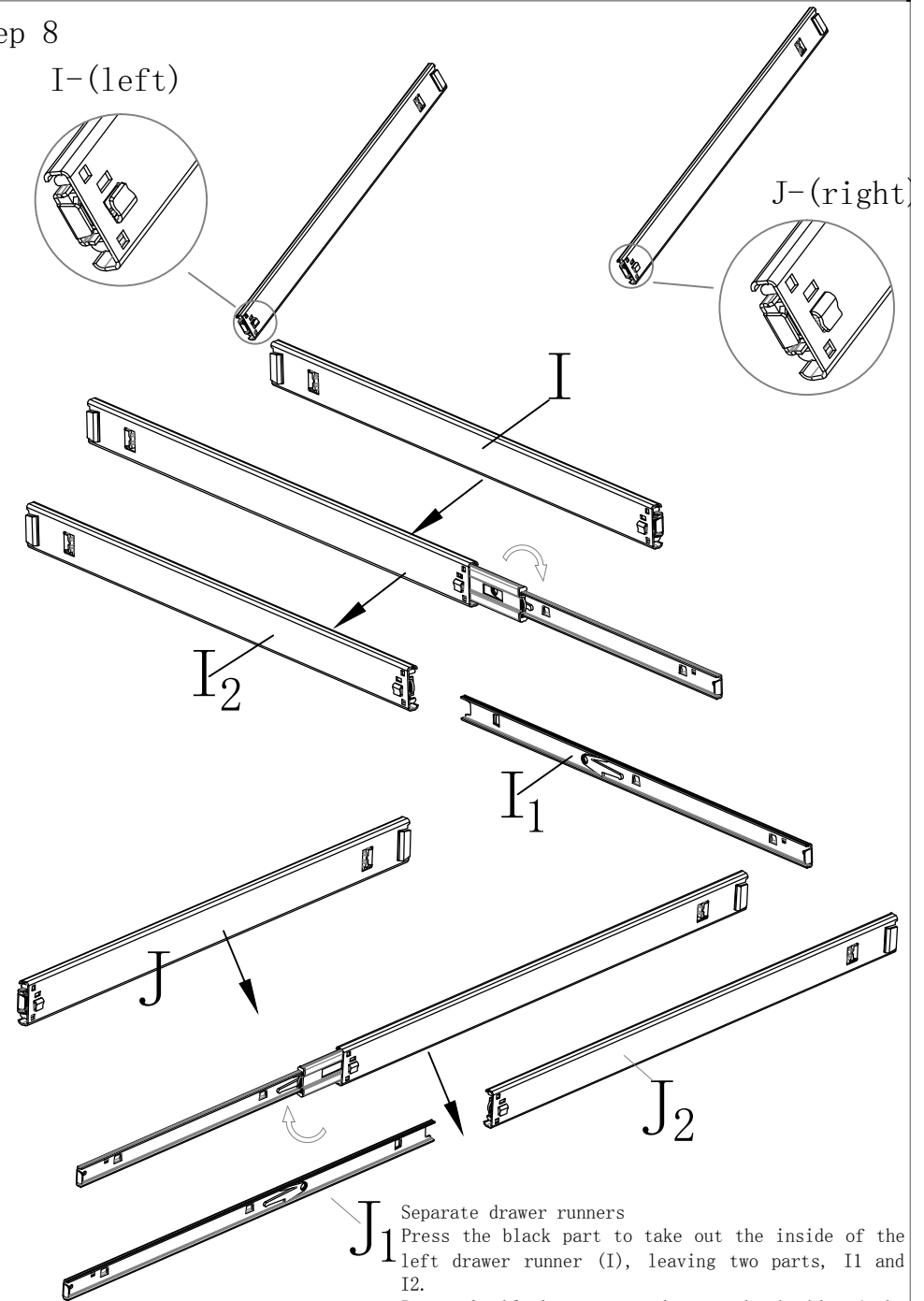

Separate drawer runners
Press the black part to take out the inside of the left drawer runner (I), leaving two parts, I1 and I2.
Press the black part to take out the inside of the right drawer runner (J), leaving two parts, J1 and J2

Step 9 Install outer drawer runners (I2 and J2)
 Attach the left outer drawer runner (I2) to the sideboard (A). Attach the right outer drawer runner (J2) to sideboard (B).

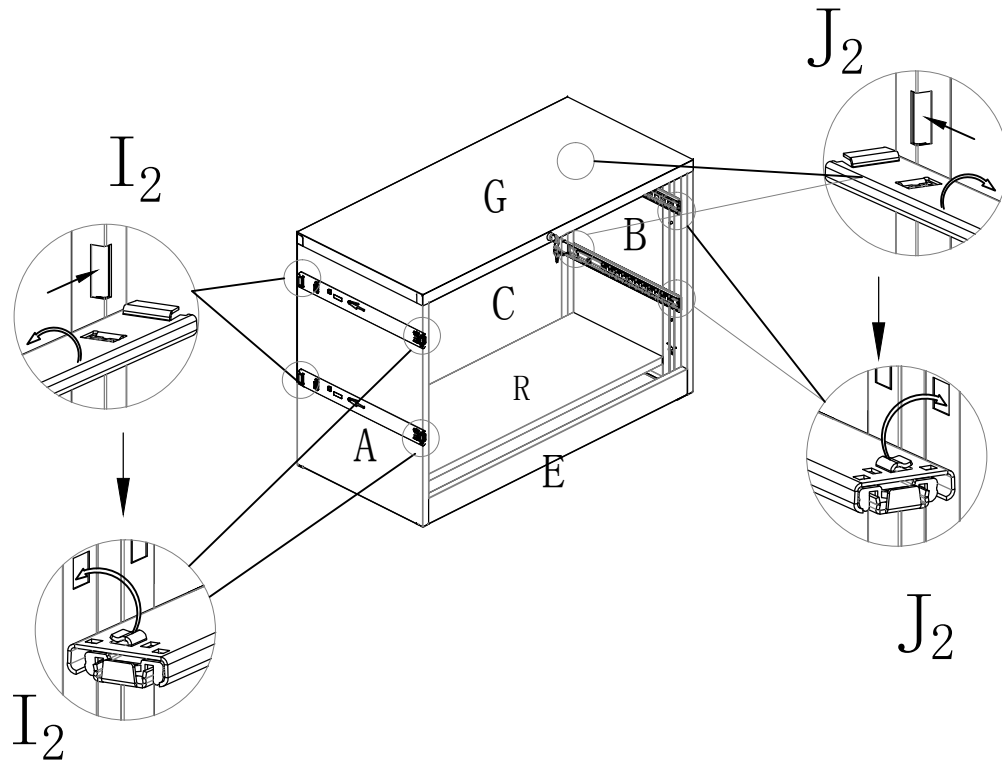

Step 10 Install drawers
 K and M were preloaded together, so first M must be removed from K. Then open the drawer body (L), and attach L to K. Lastly, attach the front guard panel (M) and back guard panel (N).
 Please note: when installing L and K, be careful not to bend the two sides of the drawer body (L) many times in order to breaking.

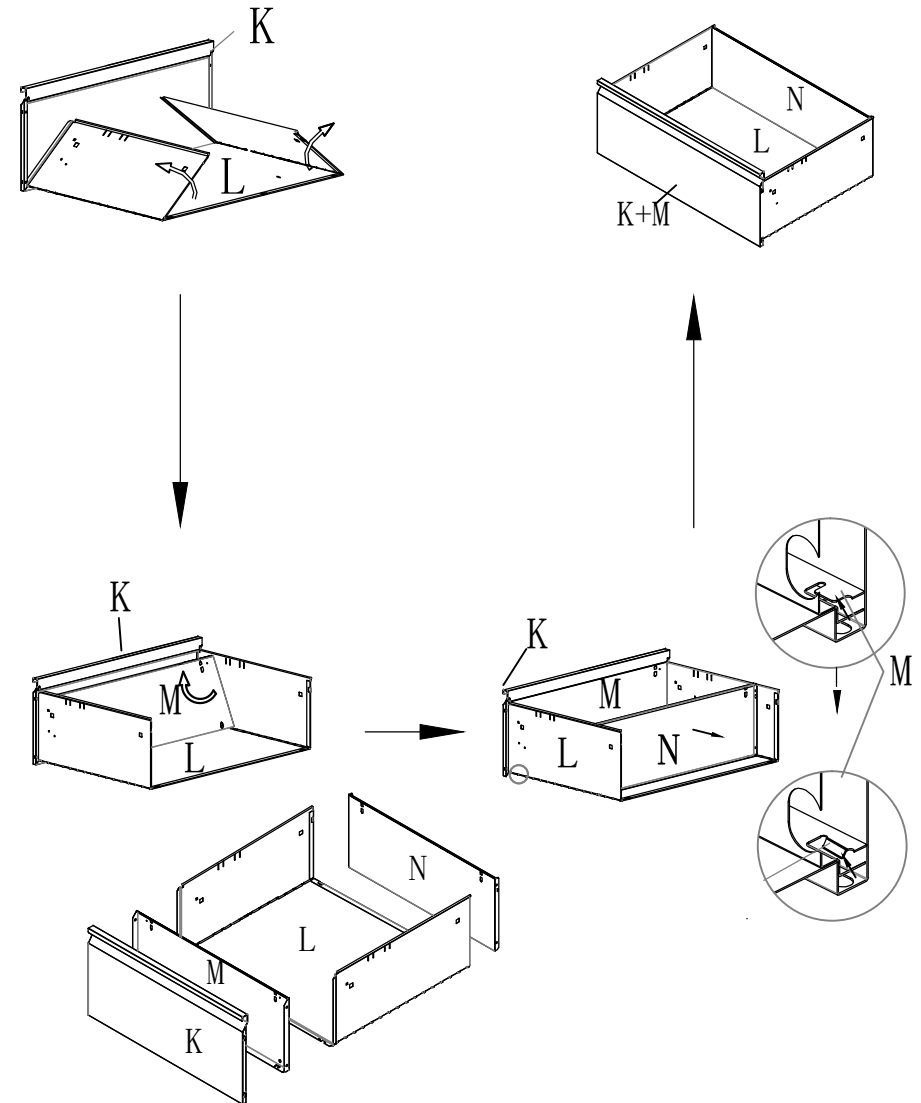

Step 11 Install inner drawer runners (I1, J1)

Attach the left inner drawer runners (I1) to the left side of the assembled drawer, and attach the right inner drawer runners (J1) to the right side of the assembled drawer.

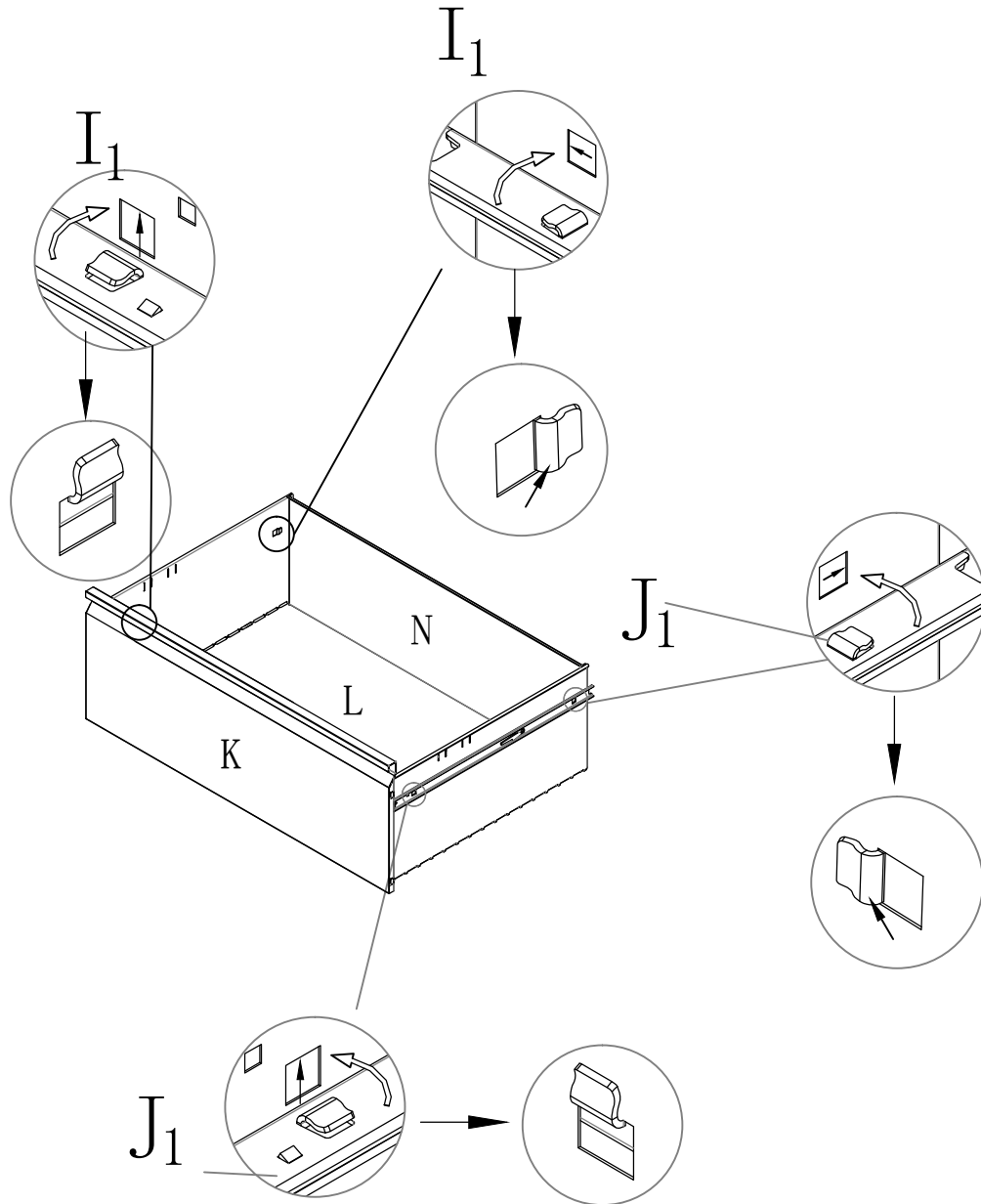

Step 12

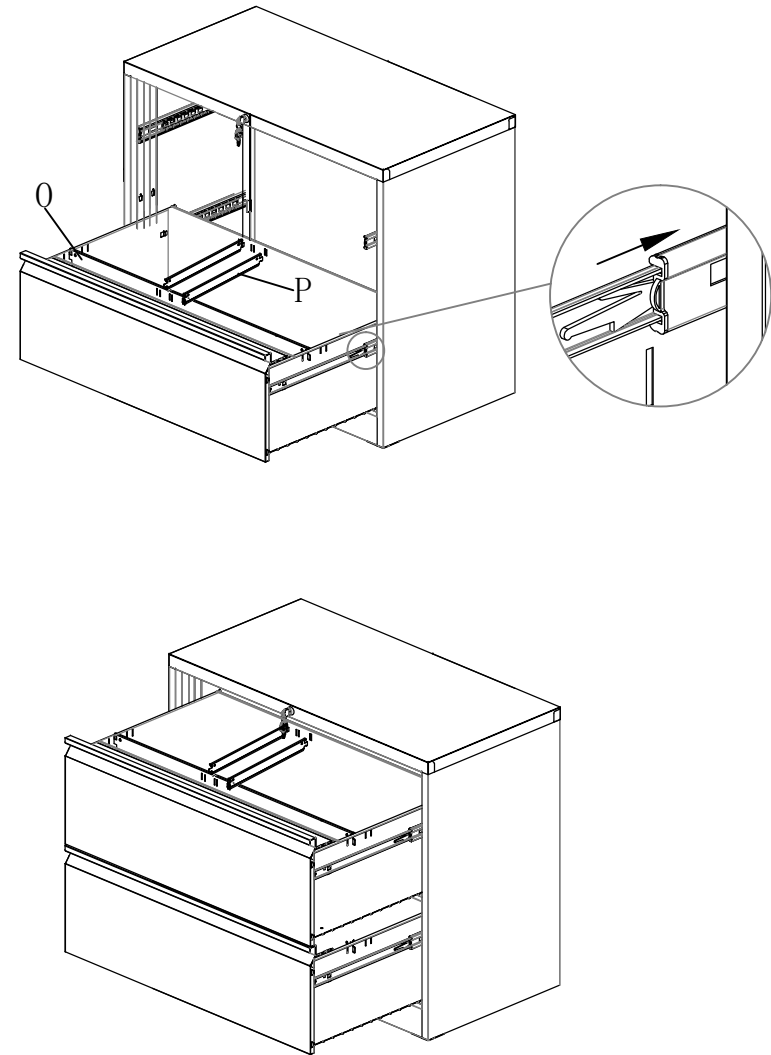

Finish assembly

Insert the assembled drawer into the cabinet by re-inserting the inner runners to the outer runners. Then, attach the horizontal hook rail (O) and the two vertical hook rails (P).

Once assembled open and close the file cabinet when unlocked. If the drawer is not closed completely, it may render the drawer unable to be locked.