

## Use & Care Guide

Models: 795.7944\* 795.7941\*

# Kenmore®

## Bottom Freezer Refrigerator

\* = color number

P/N MFL67851303-1

Sears Brands Management Corporation  
Hoffman Estates, IL 60179 U.S.A.  
[www.kenmore.com](http://www.kenmore.com)



# TABLE OF CONTENTS

<b>Warranty</b> .....	3	<b>► Freezer Section</b>	
<b>Product Record</b> .....	4	Ice Bin .....	24
<b>Important Safety Instructions</b> .....	5-7	Pullout Drawer .....	24
<b>Electrical &amp; Grounding Requirements</b> .....	7	Durabase Divider .....	24
<b>Parts and Features</b> .....	8	<b>Care And Cleaning</b> .....	25-26
<b>Refrigerator Installation</b> .....	9-22	General Cleaning Tips .....	25
Unpacking Your Refrigerator.....	9	Exterior .....	25
Installation .....	10	Inside Walls .....	25
Removing/Replacing Doors and		Door Liner And Gaskets.....	25
Drawers .....	11-13	Plastic Parts.....	25
Reversing Doors and Handles .....	14-17	Condenser Coils.....	25
Leveling and Door Alignment .....	18	Light Replacement .....	26
<b>Using Your Refrigerator</b> .....	19-22	Power Interruptions .....	26
Setting the Controls .....	19-20	When You Go On Vacation.....	26
Automatic Icemaker .....	20-21	When You Move.....	26
Food Storage Guide .....	22	<b>Connecting the Water Line</b> .....	27-29
<b>► Refrigerator Section</b>		<b>Troubleshooting Guide</b> .....	30-36
Adjusting Shelves .....	23	<b>Diagnostics</b> .....	37
Humidity Controlled Crisper.....	23	<b>Service</b> .....	Back Cover
Pantry Drawer .....	23		
Door Bins .....	24		
Dairy Bin .....	24		

# WARRANTY



## REFRIGERATOR WARRANTY

### KENMORE LIMITED WARRANTY

WITH PROOF OF SALE, the following warranty coverage applies when this appliance is correctly installed, operated and maintained according to all supplied instructions.

#### One Year on Appliance

FOR ONE YEAR from the date of sale this appliance is warranted against defects in material or workmanship. A defective appliance will receive free repair. If the appliance cannot be repaired it will be replaced free of charge. This warranty coverage applies for only 90 days from the sale date if the appliance is ever used for other than private household purposes.

#### Lifetime on Storage Bins

FOR AS LONG AS IT IS USED from the date of sale, a free replacement will be supplied for a defective refrigerator or freezer compartment storage bin.\* If the defect appears within the first year, a new bin will be installed at no charge. If the defect appears after the first year, a new bin will be supplied but not installed at no charge. This Lifetime warranty covers only storage bins, and does not apply to any other related component or mechanism. You are responsible for the labor cost of bin installation after the first year from the date of sale. This warranty coverage applies for only 90 days from the date of sale if the appliance is ever used for other than private household purposes.

\*Warranty coverage applies to door bins, drawer bins and basket bins. Defects must be verified by a Sears authorized service representative.

For warranty coverage details to obtain free repair or replacement, visit the web page: [www.kenmore.com/warranty](http://www.kenmore.com/warranty)

**This warranty covers ONLY defects in material and workmanship, and will NOT pay for:**

1. Expendable items that can wear out from normal use, including but not limited to filters, belts, bags or screw-in base light bulbs.
2. A service technician to clean or maintain this appliance, or to instruct the user in correct appliance installation, operation and maintenance.
3. Service calls to correct appliance installation not performed by Sears authorized service agents, or to repair problems with house fuses, circuit breakers, house wiring, and plumbing or gas supply systems resulting from such installation.
4. Damage to or failure of this appliance resulting from installation not performed by Sears authorized service agents, including installation that was not in accord with electrical, gas or plumbing codes.
5. Damage to or failure of this appliance, including discoloration or surface rust, if it is not correctly operated and maintained according to all supplied instructions.
6. Damage to or failure of this appliance, including discoloration or surface rust, resulting from accident, alteration, abuse, misuse or use for other than its intended purpose.
7. Damage to or failure of this appliance, including discoloration or surface rust, caused by the use of detergents, cleaners, chemicals or utensils other than those recommended in all instructions supplied with the product.
8. Damage to or failure of parts or systems resulting from unauthorized modifications made to this appliance.
9. Service to an appliance if the model and serial plate is missing, altered, or cannot easily be determined to have the appropriate certification logo.

#### Disclaimer of implied warranties; limitation of remedies

Customer's sole and exclusive remedy under this limited warranty shall be product repair or replacement as provided herein. Implied warranties, including warranties of merchantability or fitness for a particular purpose, are limited to one year on the appliance and for as long as used on the storage bins, or the shortest period allowed by law. Seller shall not be liable for incidental or consequential damages. Some states and provinces do not allow the exclusion or limitation of incidental or consequential damages, or limitation on the duration of implied warranties of merchantability or fitness, so these exclusions or limitations may not apply to you.

This warranty applies only while this appliance is used in the United States.

This warranty gives you specific legal rights, and you may also have other rights which vary from state to state.

**Sears Brands Management Corporation, Hoffman Estates, IL 60179**

## PRODUCT RECORD

In the space below, record the date of purchase, model and serial number of your product. You will find the model and serial number printed on an identification label located on the interior liner of the refrigerator compartment. Have these items of information available whenever you contact Sears concerning your product.

Model No. \_\_\_\_\_

Date of Purchase \_\_\_\_\_

Serial No. \_\_\_\_\_

Save these instructions and attach your sales receipt for future reference.

# IMPORTANT SAFETY INSTRUCTIONS

## BASIC SAFETY PRECAUTIONS

This guide contains many important safety messages. Always **read and obey** all safety messages.



This is the safety alert symbol. It alerts you to safety messages that inform you of hazards that can kill or hurt you or others, or cause damage to the product.

All safety messages will be preceded by the safety alert symbol and the hazard signal word DANGER, WARNING or CAUTION. These words mean:

**! DANGER**

You **will** be killed or seriously injured if you do not follow instructions.

**! WARNING**

You **can** be killed or seriously injured if you do not follow instructions.

**! CAUTION**

Indicates an imminently hazardous situation which, if not avoided, **may** result in minor or moderate injury, or product damage.

All safety messages will identify the hazard, tell you how to reduce the chance of injury, and tell you what can happen if the instructions are not followed.

## **! WARNING**

**To reduce the risk of fire, electric shock, or personal injury when using your product, basic safety precautions should be followed, including the following.**

**Read all instructions before using this appliance.**

- NEVER unplug your refrigerator by pulling on the power cord. Always grip the plug firmly and pull it straight out from the outlet.
- Immediately repair or replace all power cords that have become frayed or otherwise damaged. Do not use a cord that shows cracks or abrasion damage along its length or at either the plug or connector end.
- Do not modify or extend the power cord length. It could cause electric shock or fire.
- When moving your refrigerator away from the wall, be careful not to roll over or damage the power cord.

- DO NOT store or use gasoline or other flammable vapors and liquids in the vicinity of this or any other appliance.
- DO NOT allow children to climb, stand, or hang on the refrigerator doors or shelves in the refrigerator. They could damage the refrigerator and seriously injure themselves.
- Keep fingers out of pinch point areas; clearances between the doors and cabinets are necessarily small. Be careful closing doors when children are in the area.
- Unplug your refrigerator before cleaning or making any repairs.

**NOTE:** It is strongly recommended that any service be performed by a qualified technician.

## SAVE THESE INSTRUCTIONS

## ! WARNING

- Before replacing a burned-out or broken light bulb, unplug the refrigerator or turn off power at the circuit breaker or fuse box in order to avoid contact with a live wire filament. (A burned-out light bulb may break when being replaced exposing the wire filament.)

**NOTE:** Some models have LED interior lighting and service should be performed by a qualified technician.

**WARNING:** Setting either or both controls to the OFF position does not remove power to the light circuit.

- When you are finished, reconnect the refrigerator to the electrical source and reset the controls (Thermostat, Refrigerator Control, and or Freezer Control, depending on the model) to the desired setting.
- This refrigerator must be properly installed in accordance with the **Attention Installer Instructions** that were taped to the front of the refrigerator.
- After your refrigerator is in operation, do not touch the cold surfaces in the freezer compartment when hands are damp or wet. Skin may adhere to the extremely cold surfaces.

- DO NOT touch the automatic ice making mechanism while the refrigerator is plugged in.
- DO NOT refreeze frozen foods which have thawed completely. The United States Department of Agriculture in Home and Garden Bulletin No. 69 says:

...You may safely refreeze frozen foods that have thawed if they still contain ice crystals or if they are still cold—below 39°F (4°C).

...Thawed ground meats, poultry or fish that have any off-odor or off-color should not be refrozen and should not be eaten. Thawed ice cream should be discarded. If the odor or color of any food is poor or questionable, dispose of it. The food may be dangerous to eat.

Even partial thawing and refreezing reduces the eating quality of foods, particularly fruits, vegetables and prepared foods. The eating quality of red meats is affected less than that of many other foods. Use refrozen foods as soon as possible to save as much of their quality as you can.

## SAVE THESE INSTRUCTIONS

## ! DANGER: RISK OF CHILD ENTRAPMENT

Junked or abandoned refrigerators are dangerous, even if they are sitting for only a few days. If you are getting rid of your old refrigerator, please follow the instructions at right to help prevent accidents (child entrapment and suffocation).

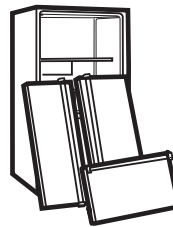

### BEFORE YOU THROW AWAY YOUR OLD REFRIGERATOR OR FREEZER:

- Take off the doors.
- Leave the shelves in place so that children may not easily climb inside.

## CFC/HCFC DISPOSAL

Your old refrigerator may have a cooling system that used CFCs or HCFCs (chlorofluorocarbons or hydrochlorofluorocarbons). CFCs and HCFCs are believed to harm stratospheric ozone if released to the atmosphere. Other refrigerants may also cause harm to the environment if released to the atmosphere.

If you are throwing away your old refrigerator, make sure the refrigerant is removed for proper disposal by a qualified technician. If you intentionally release refrigerant, you may be subject to fines and imprisonment under provisions of environmental legislation.

## ELECTRICAL & GROUNDING REQUIREMENTS

**IMPORTANT:** Please read carefully.  
**TO CONNECT ELECTRICITY**

### **! WARNING**

#### **Electrical Shock Hazard**

**FOR PERSONAL SAFETY**, this appliance must be properly grounded. Have the wall outlet and the circuit checked by a qualified electrician to make sure the outlet is properly grounded.

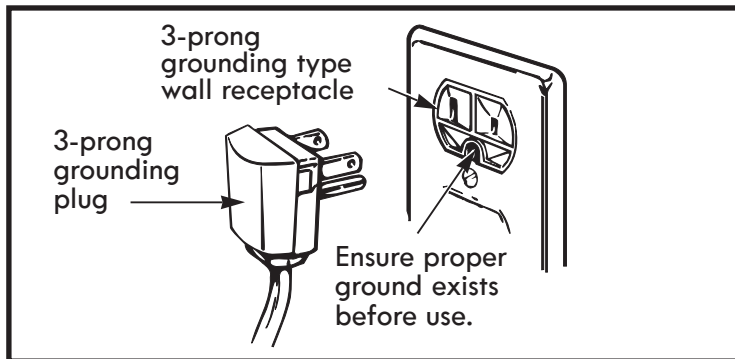

### **RECOMMENDED GROUNDING METHOD**

The refrigerator should always be plugged into its own individual properly grounded electrical outlet rated for 115 Volts, 60 Hz, AC only, and fused at 15 or 20 amperes. This provides the best performance and also prevents overloading house wiring circuits which could cause a fire hazard from overheated wires. It is recommended that a separate circuit serving only this appliance be provided.

Use a receptacle that cannot be turned off with a switch or pull chain. Do not use an extension cord.

Where a standard two-prong wall outlet is encountered, it is your personal responsibility and obligation to have it replaced with a properly grounded three-prong wall outlet.

### **USE OF EXTENSION CORDS**

**Because of potential safety hazards under certain conditions, the use of an extension cord is not recommended.** However, if you still elect to use an extension cord, it is absolutely necessary that it be a UL-listed (USA), 3-wire grounding type appliance extension cord having a grounding type plug and outlet, and that the electrical rating of the cord be 15 amperes (minimum) and 120 volts.

Use of an extension cord will increase the clearance needed for the back of the refrigerator.

## Freezer Swing Model

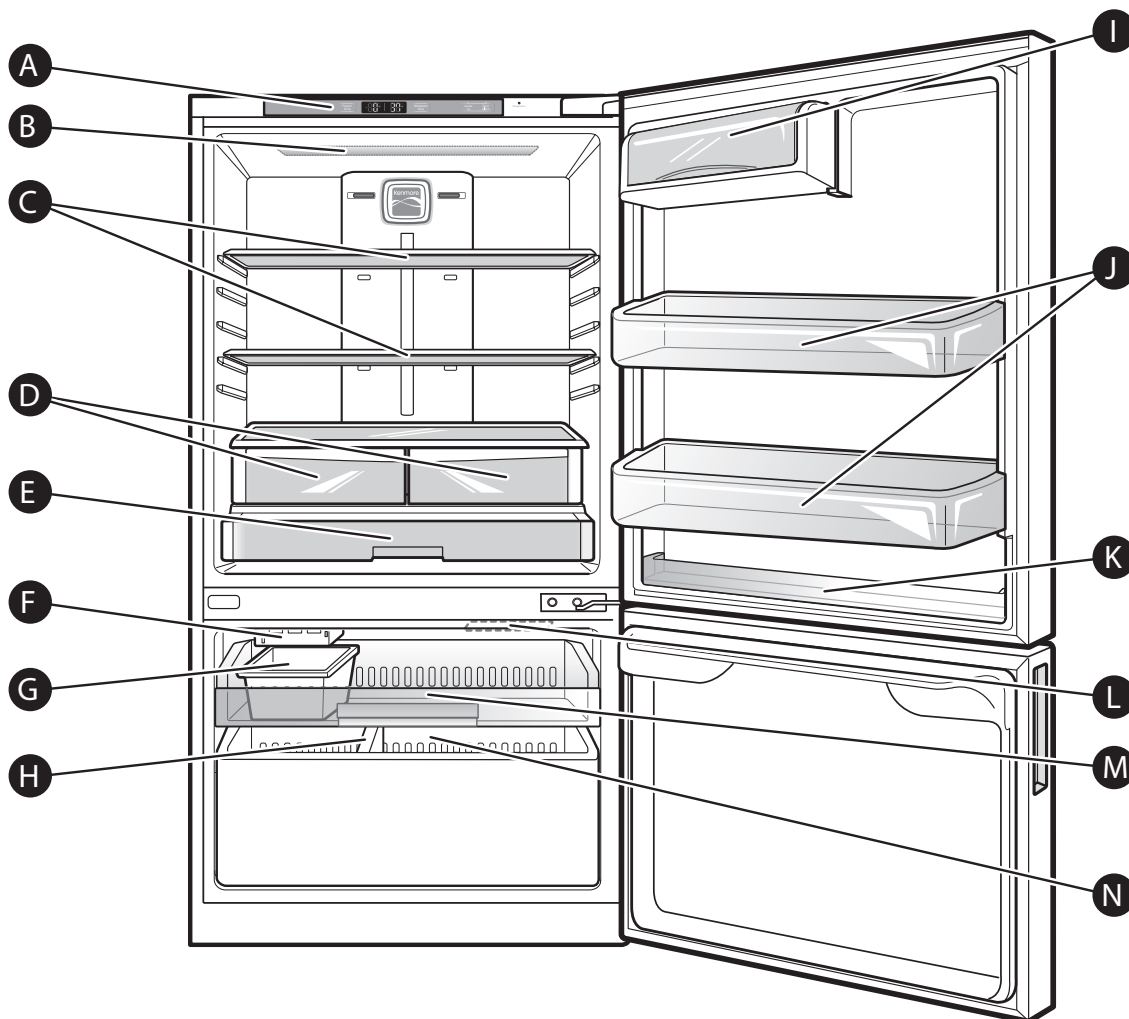

Use this page to become more familiar with the parts and features of your refrigerator.

**NOTE:** This guide covers several different models. The refrigerator you have purchased may have some or all of the items listed below. The locations of the features shown below may not match your model.

- |                                       |                           |                         |
|---------------------------------------|---------------------------|-------------------------|
| <b>A</b> Digital Sensor Control       | <b>G</b> Ice Bin          | <b>M</b> Pullout Drawer |
| <b>B</b> Refrigerator Light           | <b>H</b> Durabase Divider | <b>N</b> Durabase       |
| <b>C</b> Refrigerator Shelf (full)    | <b>I</b> Dairy Bin        |                         |
| <b>D</b> Humidity Controlled Crispers | <b>J</b> Door Bins        |                         |
| <b>E</b> Pantry                       | <b>K</b> Condiment Bin    |                         |
| <b>F</b> Icemaker*                    | <b>L</b> Freezer Light    |                         |



# REFRIGERATOR INSTALLATION

## **WARNING**

### **Excessive Weight Hazard:**

Use two or more people to move and install the refrigerator. Failure to do so can result in back or other injury.

## **WARNING**

### **Excessive Weight Hazard:**

Your refrigerator is heavy. When moving the refrigerator for cleaning or service, be sure to protect the floor. Always pull the refrigerator straight out when moving it. Do not wiggle or walk the refrigerator when trying to move it, as floor damage could occur.

## **UNPACKING YOUR REFRIGERATOR**

Remove tape and any temporary labels from your refrigerator before using. Please remove vinyl from doors before connecting unit to the electrical supply (on some models). Do not remove any warning-type labels, the model and serial number label, or the Tech Sheet that is located under the front of the refrigerator.

To remove any remaining tape or glue, rub the area briskly with your thumb. Tape or glue residue can also be easily removed by rubbing a small amount of liquid dish soap over the adhesive with your fingers. Wipe with warm water and dry.

Do not use sharp instruments, rubbing alcohol, flammable fluids, or abrasive cleaners to remove tape or glue. These products can damage the surface of your refrigerator.

Refrigerator shelves are installed in the shipping position. Please reinstall shelves according to your individual storage needs.

## **WARNING**

### **Explosion Hazard:**

Keep flammable materials and vapors, such as gasoline, away from the refrigerator. Failure to do so can result in fire, explosion, or death.

## PRIOR TO USE

1. Clean your refrigerator thoroughly and wipe off all dust that accumulated during shipping.
2. Install accessories such as ice cube bin, drawers, shelves, etc., in their proper places. They are packed together to prevent possible damage during shipment.
3. Allow your refrigerator to run for at least two to three hours before putting food in it. Check the flow of cold air in the freezer compartment to ensure proper cooling. Your refrigerator is now ready for use.

## INSTALLATION

The refrigerator should always be plugged into its own individual properly grounded electrical outlet rated for 115 Volts, 60 Hz, AC only, and fused at 15 or 20 amperes. This provides the best performance and also prevents overloading house wiring circuits which could cause a fire hazard from overheated wires. It is recommended that a separate circuit serving only this appliance be provided.

### **! WARNING**

#### **Shock Hazard:**

To reduce the risk of electric shock, do not install the refrigerator in a wet or damp area.

## INSTALLATION (continued)

1. To avoid noise and vibration, the unit must be leveled and installed on a solidly constructed floor. If required, adjust the leveling legs to compensate for unevenness of the floor. The front should be slightly higher than the rear to aid in door closing. Leveling legs can be turned easily by tipping the cabinet slightly. Turn the leveling legs to the left to raise the unit or to the right to lower it. (See **LEVELING AND DOOR ALIGNMENT**.)

**NOTE:** Installing on carpeting, soft tile surfaces, a platform or weakly supported structure is not recommended.

2. Install this appliance in an area where the temperature is between 55°F (13°C) and 110°F (43°C). If the temperature around the appliance is too low or high, cooling ability may be adversely affected.
3. Select a place where a water supply can be easily connected for the automatic icemaker.

**NOTE:** The water pressure must be between 20 and 120 psi on models without a water filter and between 40 and 120 psi on models with a water filter.

4. Too small of a distance from adjacent items may result in lowered freezing capability and increased electricity consumption charges. Allow at least 33 ¾ inches (86 cm) in front of the refrigerator to open the doors and at least 2 inches (5.08 cm) between the back of the refrigerator and the wall.

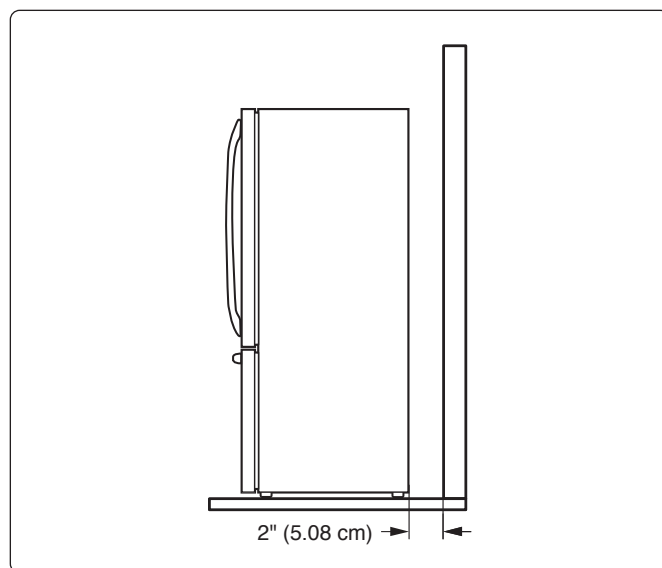

**NOTE:** Removing the doors is the recommended procedure when it is necessary to move the refrigerator through a narrow opening. If it is necessary to remove the handles, follow the directions below.

## HOW TO REMOVE REFRIGERATOR DOOR HANDLE

**NOTE:** Handle appearance may vary from illustrations on this page.

### Removing Refrigerator Handle

Loosen the set screws with a  $\frac{3}{32}$  in. Allen wrench and remove the handle.

**NOTE:** If the handle mounting fasteners need to be tightened or removed, use a  $\frac{1}{4}$  in. Allen wrench.

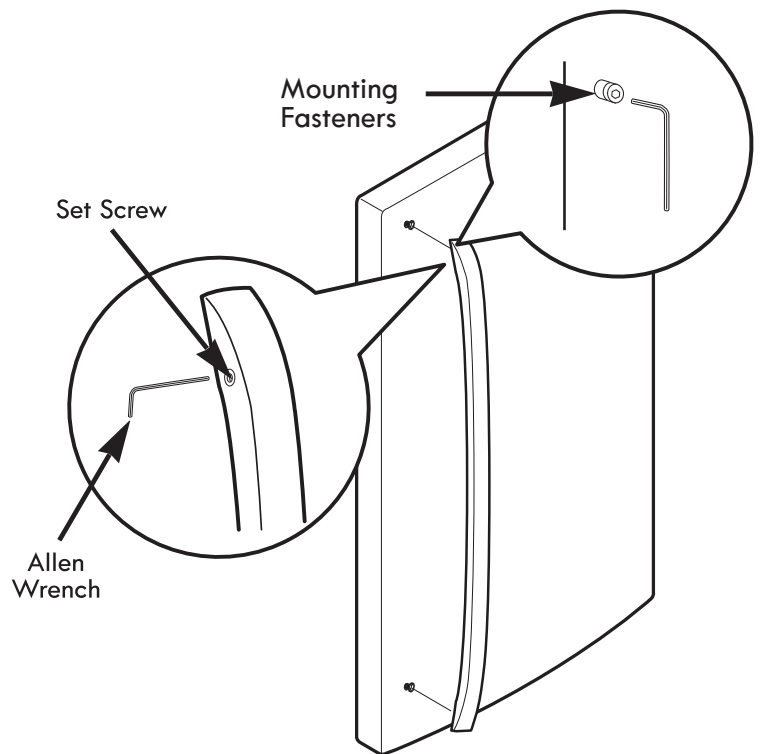

## HOW TO REPLACE REFRIGERATOR DOOR HANDLE

**NOTE:** Handle appearance may vary from illustrations on this page.

### Replacing Refrigerator Door Handle

Place the handle on the door by fitting the handle footprints over the mounting fasteners and tightening the set screws with a  $\frac{3}{32}$  in Allen wrench.

**NOTE:** If the handle mounting fasteners need to be tightened or removed, use a  $\frac{1}{4}$  in. Allen wrench.

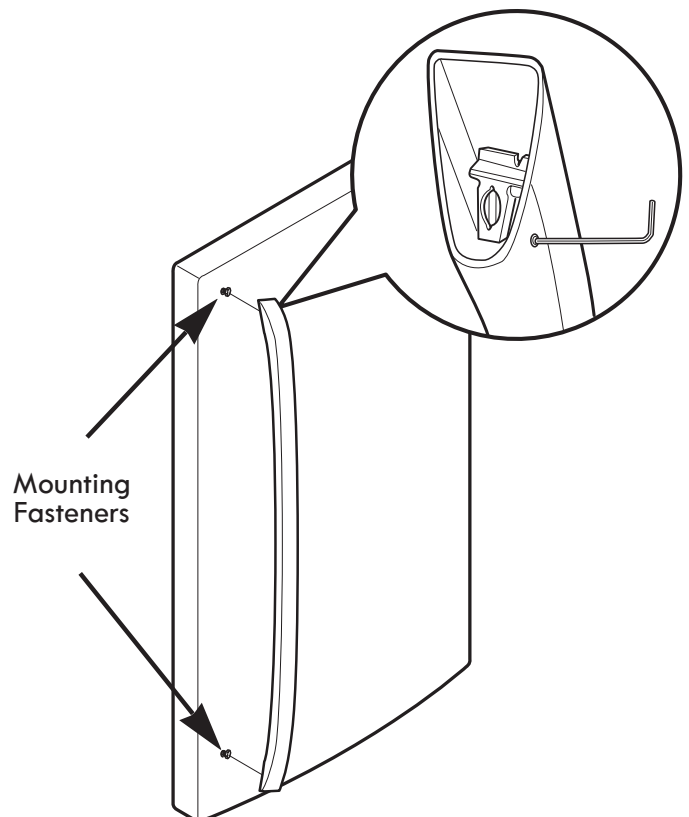

## REMOVING AND REPLACING REFRIGERATOR DOORS

### ⚠ WARNING

#### Excessive Weight Hazard:

Use two or more people to remove and install the refrigerator doors. Failure to do so can result in back or other injury.

### ⚠ WARNING

#### Electrical Shock Hazard

- Disconnect the electrical supply to the refrigerator before installing. Failure to do so could result in serious injury or death.
- Do not put hands, feet or other objects into the air vents or bottom of the refrigerator. You may be injured or receive an electrical shock.

⚠ **CAUTION:** Before you begin, remove food and bins from the doors.

#### Removing the Refrigerator Door

1. Open the door. Remove the top hinge cover screws (1).

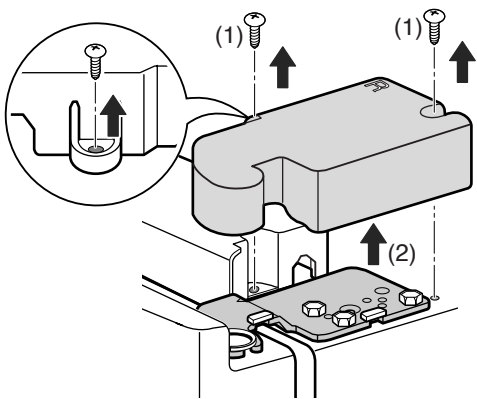

2. Lift up the cover (2) and remove it.

3. Remove the three bolts using a 10mm or 13/32-inch socket wrench and lift off the top hinge.

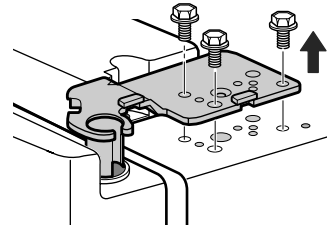

⚠ **CAUTION:** When removing the bolts, be careful that the door does not fall forward.

4. Lift the door from the middle hinge pin and remove the door.

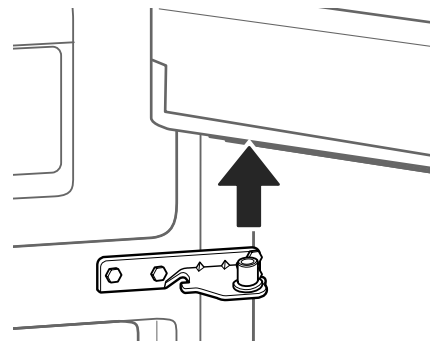

5. Place the door, inside facing up, on a non-scratching surface.

### Reinstalling the Refrigerator Door

- 1 Make sure that the plastic sleeve is inserted in the bottom of the door. Lower the door onto the middle hinge pin as shown in the figure.

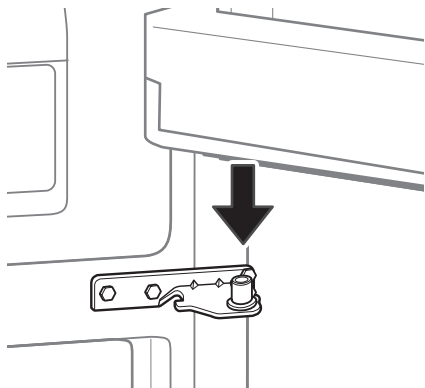

- 2 Align the door with the cabinet.
- 3 Line up the top hinge with the holes in the top of the refrigerator. Insert and tighten the three bolts in the hinge.

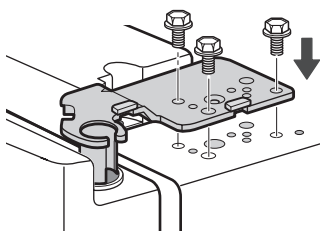

- 4 Replace the cover. Insert and tighten the cover screws (2).

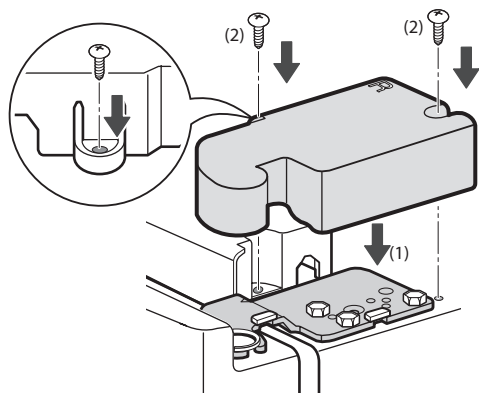

### HOW TO REMOVE THE FREEZER DOOR

**NOTE:** Before removing the freezer door, make sure you completely remove the refrigerator door.

- 1 Use a 1/4 in. hex socket wrench to loosen and remove the hinge pin from the middle hinge bracket. Use a 10 mm or 13/32 in. socket wrench to remove the two bolts. Remove the screw and set the middle hinge bracket and other parts aside. Remove the washer.

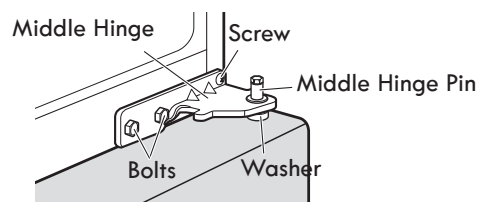

- 2 Carefully lift up the freezer door. Remove and place it on a non-scratching surface.

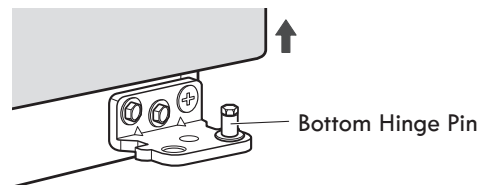

### HOW TO INSTALL THE FREEZER DOOR

- 1 Place the freezer door down on the bottom hinge pin.

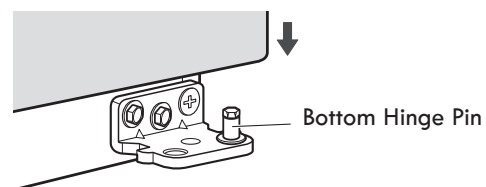

- 2 Replace the washer and the middle hinge bracket. Use a 10 mm or 13/32 in. socket wrench to insert and tighten the bolts. Insert the screw. Reattach the middle hinge pin using a 1/4 in. socket wrench.

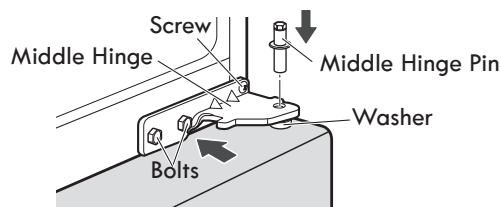

## REVERSING REFRIGERATOR DOORS

### ⚠ WARNING

#### Electrical Shock Hazard

Before you begin, either unplug the refrigerator or turn off power at the circuit breaker or fuse box. Failure to do so could result in death or serious injury.

### ⚠ CAUTION

Remove food and any adjustable door or utility bins from doors. Failure to do so could result in serious injury.

#### TOOLS NEEDED

- 10mm or 13/32-inch socket wrench (with 2-inch extension for bottom door hinge)
- No. 2 Phillips head screwdriver
- 1/4 inch socket wrench
- Flat-head screwdriver for prying
- Adjustable wrench

#### Reversing Doors

You may find it more convenient to have the doors open from the right, rather than from the left as installed by the factory. The "right side" referred to in the directions is the side on your right as you face the front of the unit.

1. Remove the top hinge cover screws (1) . Remove the cover(2) by lifting the hidden hook inside the bottom of the front side of the cover, with a flat-head screwdriver.

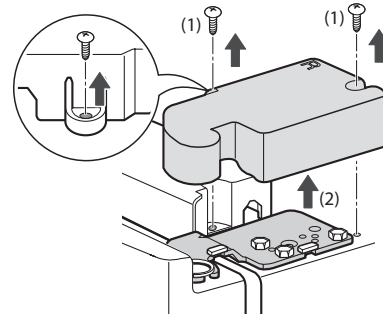

2. Using a 10mm or 13/32-inch socket wrench, remove the three bolts and lift off the top hinge. Set parts aside.

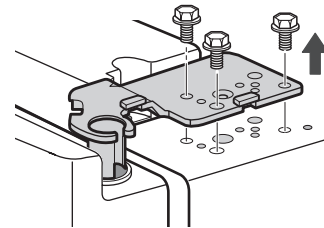

- ⚠ CAUTION:** When removing the bolts, be careful that the door does not fall forward.

3. Lift the door from the middle hinge pin and remove the door.

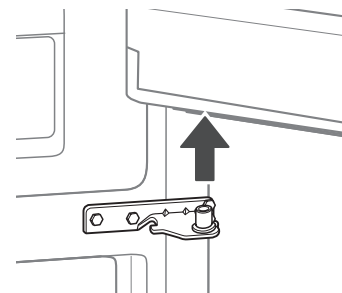

- ⚠ CAUTION:** Place the door, inside facing up, on a non-scratching surface.

4. Remove the four screws (1), the hinge pin insert (2) and the hinge pin brackets (3) from the bottom right side of the door.

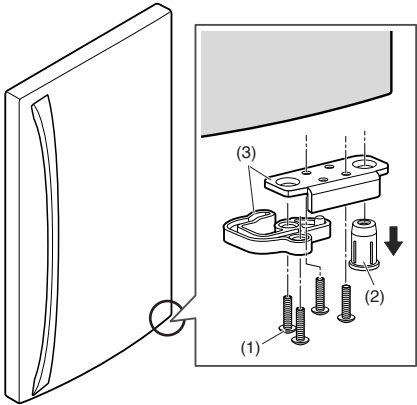

5. Reinstall the hinge pin brackets (1), screws (2) and hinge pin insert (3) on the bottom left side of the door.

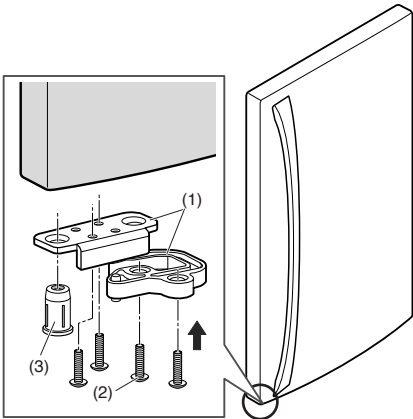

**NOTE:** Before removing the freezer door, make sure you completely remove the refrigerator door.

6. Use a 1/4 inch hex socket wrench to loosen and remove the hinge pin (1) from the middle hinge bracket. Use a 10 mm or 13/32 in. socket wrench to remove the two bolts (2). Remove the screw (3) and set the middle hinge bracket (4) and other parts aside.

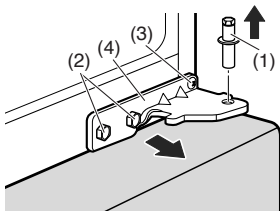

7. Carefully lift up the freezer door. Remove and place it on a non-scratching surface.

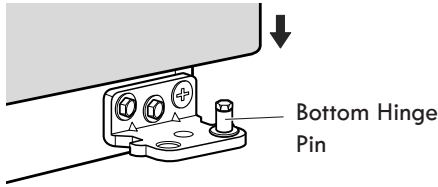

8. Using a 1/4 in. socket wrench, loosen and remove the hinge pin from the bottom hinge.

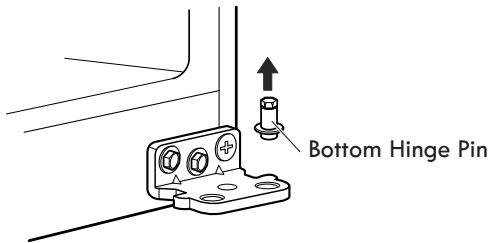

9. Using a 13/32-inch or 10mm socket wrench with a 2 in. extension and a screwdriver, loosen the two bolts and the screw, and remove the bottom hinge on right side.

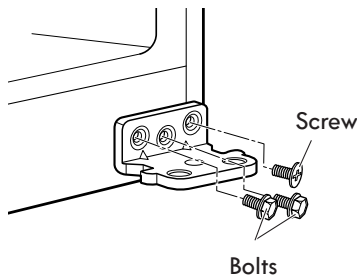

10. Remove the four screws (1), the hinge pin brackets (2) and the hinge pin insert from the bottom right side of the freezer door.

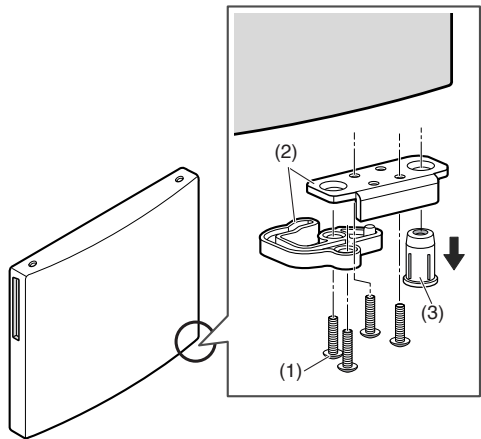

## REFRIGERATOR INSTALLATION

11. Reinstall the hinge pin insert (1), the hinge pin brackets (2) and screws (3) on the bottom left side of the door.

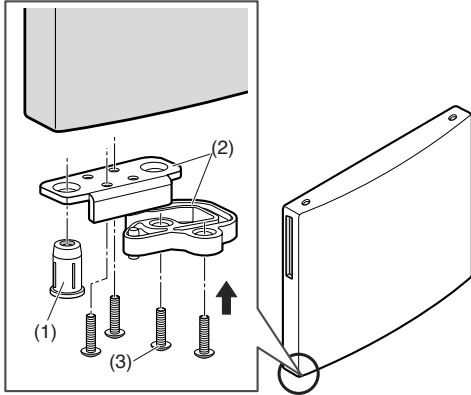

12. On the top part of the door, you will find a cap (1) and a pivot (2). Remove it with a flat head screwdriver and install it on the opposite side ( the cap stays on the right and the pivot on the left).

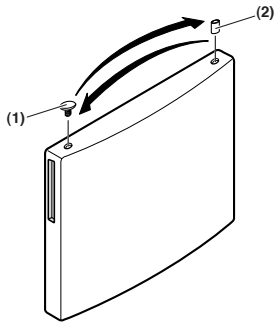

13. Remove the decorative caps on the bottom of the refrigerator housing. You will need these holes for the Bottom Hinge.

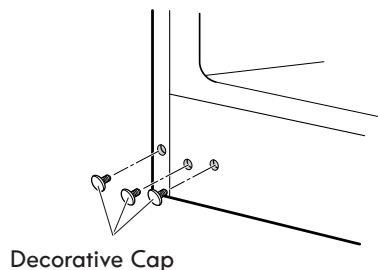

14. Using a 13/32 in. socket wrench with a 2 in. extension and a screwdriver, tighten the two bolts and a screw, and attach the bottom hinge on left side of the flange.

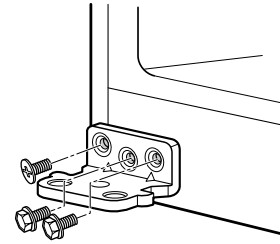

15. Attach the hinge pin using a 1/4 in. socket wrench.

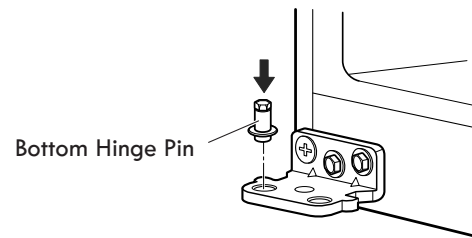

16. With a flat-head screwdriver, carefully pry off and remove the cover over the bolt holes on the left side of refrigerator.

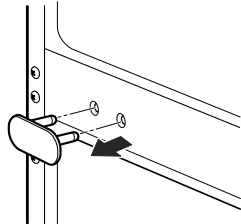

17. Remove the outer lower decorative screw from the flange on the frame between the freezer and refrigerator doors. (You will need this hole for the middle hinge bracket.)

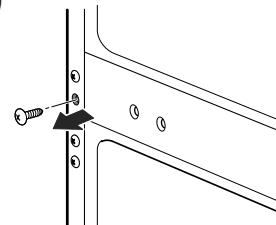



18. Flip the middle hinge bracket and position on left side of refrigerator. Re-attach with two bolts and a screw.

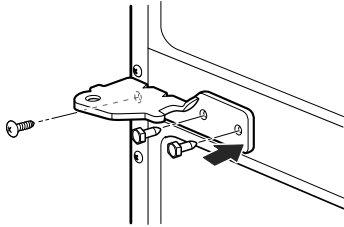

19. Place freezer door down on bottom hinge pin.

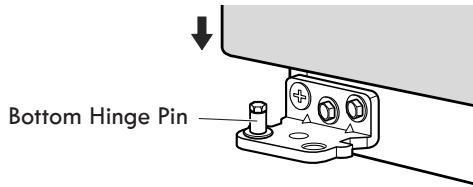

20. Reattach middle hinge pin using a 1/4 in. socket wrench. Replace washer.

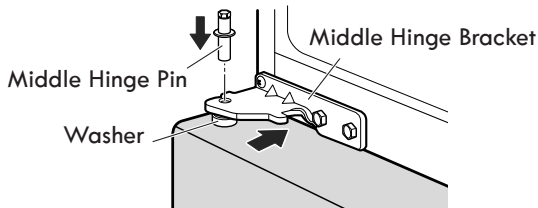

**NOTE:** Bracket has been flipped, but hinge pin stays in the same orientation with its hexagonal end facing upward.

21. Insert the decorative screw into the outer hole on the right side of the housing. Attach cover on the right side. Cover is force-fitted.

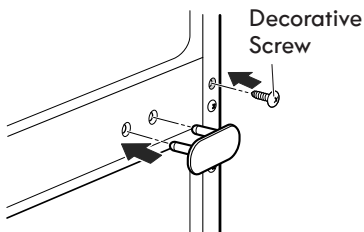

22. Loosen the two screws and remove the left hinge cap.

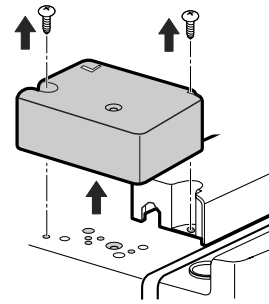

23. Place the refrigerator door down over the hinge pin on the middle hinge pin bracket.

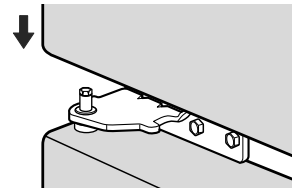

**NOTE:** The left top hinge, left hinge cover and right hinge cap are provided for reversing doors.

24. Line up the left top hinge with the holes in the top of refrigerator. Use the three bolts to replace the hinge. Replace the left hinge cover and insert the two screws.

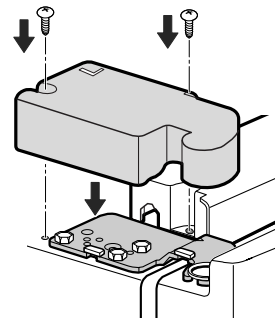

25. Replace the right hinge cap and insert the two screws.

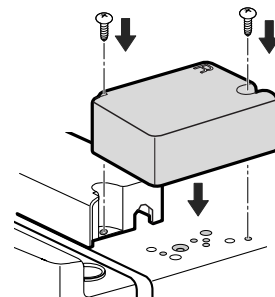

## LEVELING AND DOOR ALIGNMENT

### LEVELING

After installing, plug the refrigerator's power cord into a 3-prong grounded outlet and push the refrigerator into the final position.

Your refrigerator has two front leveling legs one on the right and one on the left. Adjust the legs to alter the tilt from front-to-back or side-to-side. If your refrigerator seems unsteady, or you want the doors to close more easily, adjust the refrigerator's tilt using the instructions below:

**NOTE:** Tools Required: 11/16 inch wrench or flat blade screwdriver.

1. Turn the leveling leg to the left to raise that side of the refrigerator or to the right to lower it. It may take several turns of the leveling leg to adjust the tilt of the refrigerator.

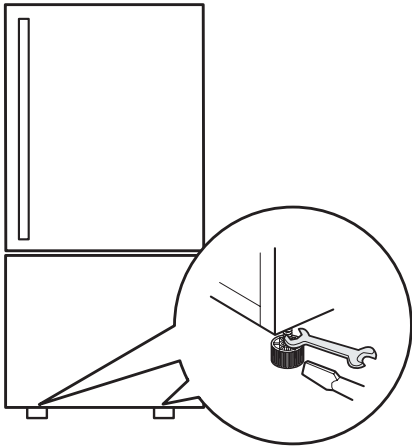

**NOTE:** Having someone push backward against the top of the refrigerator takes some weight off of the leveling legs. This makes it easier to adjust the legs.

2. Open both doors again and check to make sure that they close easily. If the doors do not close easily, tilt the refrigerator slightly more to the rear by turning both leveling legs to the left. It may take several more turns, and you should turn both leveling legs the same amount.

### DOOR ALIGNMENT

If the space between your doors is uneven, follow the instructions below to align the doors.

1. Remove the top hinge cover screws. Lift the hook located at the bottom of the front side of the cover with a flat-head screwdriver.
2. Loosen the top hinge bolts using a 10mm or 13/32-in. socket wrench or open-end wrench.
3. Have someone hold the refrigerator door so the space between the two door is even, and retighten the top hinge bolts.
4. Replace the top hinge cover.

# USING YOUR REFRIGERATOR

## SETTING THE CONTROLS

### AIRFLOW

Be sure not to block vents while packing your refrigerator. Doing so will restrict airflow and may cause the refrigerator temperature to become too warm or cause interior moisture buildup. (See the air flow diagram below.)

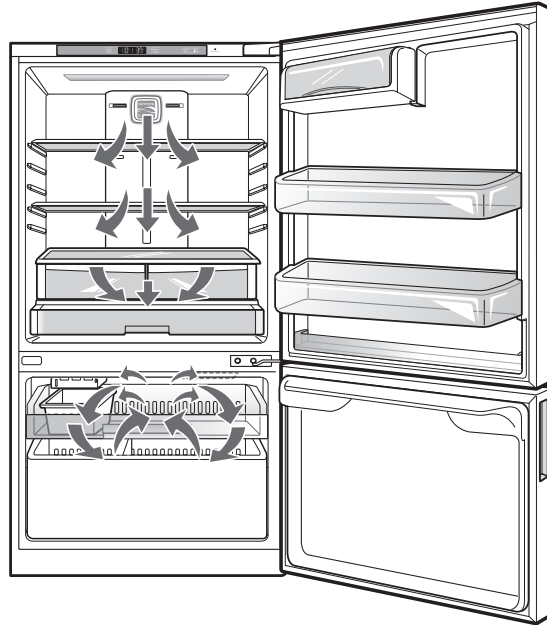

### TEMPERATURE

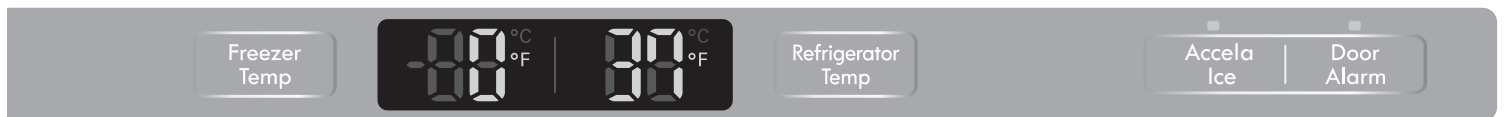

- **The Refrigerator Temp Control ranges from 33°F to 46°F (0°C to 8°C).** Press the Refrigerator Temp button to cycle through the available temperature settings one increment at a time.
- **The Freezer Temp Control range is from -6°F to 8°F (-21°C to -13°C).** Press the Freezer Temp button to cycle through the available temperature settings one increment at a time.

**NOTE:** When changing control settings, wait 24 hours before making additional adjustments. The controls are set correctly when milk or juice is as cold as you would like and when ice cream is firm. If the temperature in either compartment is too cold or too warm, change the setting one increment at a time. Wait 24 hours for the change to stabilize before adjusting again.

**NOTE:** The Condiment bin is not recommended for storing items that spoil easily such as milk and mayonnaise.

## ACCELA ICE

- When you press and hold the **Accela Ice** button, the light will be on in the display and will continue for 24 hours. The function will automatically shut off after 24 hours.
- You can stop this function manually by pressing the button one more time.
- This function increases both ice making and freezing capabilities.

## DOOR ALARM

- When power is connected to the refrigerator, the door alarm is initially set to ON. When you press the **Door Alarm** button, the display will change to OFF and the **Door Alarm** function will deactivate.
- When either the refrigerator or the freezer door is left open for more than 60 seconds, the alarm tone will sound to let you know that the door is open.
- When you close the door, the door alarm will stop.

## TEMPERATURE MODE SWITCH FUNCTION (°F <->°C)

If you want to convert °F to °C or vice versa, press and hold the **Freezer Temp** and **Refrigerator Temp** buttons at the same time for approximately five seconds.

## DEMO MODE (FOR STORE USE ONLY)

**Demo Mode** disables all cooling in the refrigerator and freezer sections to conserve energy while on display in a retail store. When activated, OFF will display on the control pad.

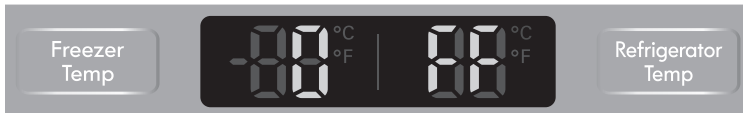

### To deactivate:

With either refrigerator door opened, press and hold the **Refrigerator Temp** and **Accela Ice** buttons at the same time for five seconds. The control pad will beep and the temperature settings will display to confirm that **Demo Mode** is deactivated. Use the same procedure to activate the **Demo Mode**.

## AUTOMATIC ICEMAKER

Ice is made in the automatic icemaker and sent to the dispenser. The icemaker will produce 70~210 cubes in a 24-hour period, depending on freezer compartment temperature, room temperature, number of door openings and other operating conditions.

- It takes about 12 to 24 hours for a newly installed refrigerator to begin making ice. Wait 72 hours for full ice production to occur.
- Ice making stops when the in-door ice bin is full. When full, the in-door ice bin holds approximately 6 to 8 (12-16 oz) glasses of ice.
- To turn off the automatic icemaker, set the icemaker switch to **OFF (O)**. To turn on the automatic icemaker, set the switch to **ON (I)**.
- The water pressure must be between 20 and 120 psi on models without a water filter and between 40 and 120 psi on models with a water filter to produce the normal amount and size of ice cubes.
- Foreign substances or frost on the ice-detecting sensor can interrupt ice production. Make sure the sensor area is clean at all times for proper operation.

## ⚠ WARNING

### Personal Injury Hazard

**DO NOT** place fingers or hands on the automatic ice making mechanism while the refrigerator is plugged in.

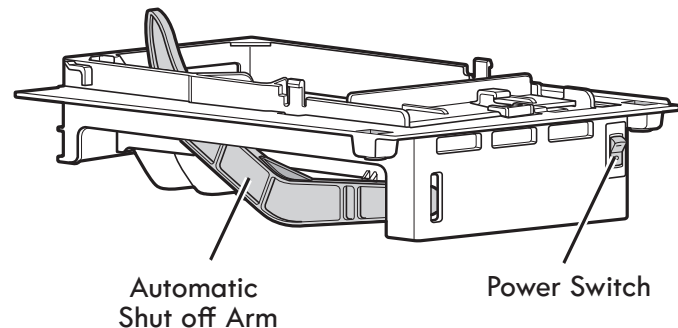

**AUTOMATIC ICEMAKER (continued)**

**⚠ CAUTION**

- The first ice produced may include particles or odor from the water supply line or the water tank.
- Throw away the first few batches of ice. This is also necessary if the refrigerator has not been used for a long time.
- If discolored ice is produced, check the water supply. If the problem continues, contact a Sears or other qualified service center. Do not use the ice or water until the problem is corrected.
- Be sure nothing interferes with the sweep of the Automatic Shut Off Arm.
- When the bin fills to the level of the Automatic Shut Off Arm, the icemaker will stop producing ice.
- It is normal for some cubes to be stuck together.
- If ice is not used frequently, old ice cubes will become cloudy, taste stale, and shrink.

**WHEN YOU SHOULD SET THE ICEMAKER POWER SWITCH TO OFF (O)**

- When the water supply will be shut off for several hours.
- When the ice bin is removed for more than one or two minutes.
- When the refrigerator will not be used for several days.

**NOTE:** The ice bin should be emptied when the icemaker ON/OFF switch is turned to the **OFF** position.

**NORMAL SOUNDS YOU MAY HEAR**

- The icemaker water valve will buzz as the icemaker fills with water. If the power switch is in the **ON (I)** position, it will buzz even if it has not yet been hooked up to water. To stop the buzzing, move the power switch to **OFF (O)**.  
**NOTE:** Keeping the power switch in the **ON (I)** position before the water line is connected can damage the icemaker.
- You will hear the sound of cubes dropping into the bin and water running in the pipes as the icemaker refills.

**PREPARING FOR VACATION**

Set the icemaker power switch to **OFF (O)** and shut off the water supply to the refrigerator.

**NOTE:** The ice bin should be emptied anytime the icemaker ON/OFF switch is turned to the **OFF (O)** position.

If the ambient temperature will drop below freezing, have a qualified technician drain the water supply system to prevent serious property damage due to flooding caused by ruptured water lines or connections.

**FOOD STORAGE GUIDE**

Wrap or store food in the refrigerator in airtight and moisture-proof material unless otherwise noted. This prevents food odor and taste transfer throughout the refrigerator. For dated products, check date code to ensure freshness.

Items	How to
<b>Butter or margarine</b>	▶ Keep opened butter in a covered dish or closed compartment. When storing an extra supply, wrap in freezer packaging and freeze.
<b>Cheese</b>	▶ Store in the original wrapping until you are ready to use it. Once opened, rewrap tightly in plastic wrap or aluminum foil.
<b>Milk</b>	▶ Wipe milk cartons. For best storage, place milk on interior shelf, not on door shelf.
<b>Eggs</b>	▶ Store in original carton on interior shelf, not on door shelf.
<b>Fruit</b>	▶ Do not wash or hull the fruit until it is ready to be used. Sort and keep fruit in its original container, in a crisper, or store in a completely closed paper bag on a refrigerator shelf.
<b>Leafy vegetables</b>	▶ Remove store wrapping and trim or tear off bruised and discolored areas. Wash in cold water and drain. Place in plastic bag or plastic container and store in crisper.
<b>Vegetables with skins (carrots, peppers)</b>	▶ Place in plastic bags or plastic container and store in crisper.
<b>Fish</b>	▶ Store fresh fish and shellfish in the freezer section if they are not being consumed the same day of purchase. It is recommended to consume fresh fish and shellfish the same day purchased.
<b>Leftovers</b>	▶ Cover leftovers with plastic wrap or aluminum foil, or store in plastic containers with tight lids.

**STORING FROZEN FOOD**

**NOTE:** Check a freezer guide or a reliable cookbook for further information about preparing food for freezing or for food storage times.

**Freezing**

Your freezer will not quick-freeze a large quantity of food. Do not put more unfrozen food into the freezer than will freeze within 24 hours (no more than 2 to 3 lbs. of food per cubic foot of freezer space). Leave enough space in the freezer for air to circulate around packages. Be careful to leave enough room at the front so the door can close tightly.

Storage times will vary according to the quality and type of food, the type of packaging or wrap used (how airtight and moisture-proof) and the storage temperature. Ice crystals inside a sealed package are normal. This simply means that moisture in the food and air inside the package have condensed, creating ice crystals.

**NOTE:** Allow hot foods to cool at room temperature for 30 minutes, then package and freeze. Cooling hot foods before freezing saves energy.

**Packaging**

Successful freezing depends on correct packaging. When you close and seal the package, it must not allow air or moisture in or out. If it does, you could have food odor and taste transfer throughout the refrigerator and could also dry out frozen food.

**Packaging recommendations:**

- Rigid plastic containers with tight-fitting lids
- Straight-sided canning/freezing jars
- Heavy-duty aluminum foil
- Plastic-coated paper
- Non-permeable plastic wraps
- Specified freezer-grade self-sealing plastic bags

Follow package or container instructions for proper freezing methods.

**Do not use**

- Bread wrappers
- Non-polyethylene plastic containers
- Containers without tight lids
- Wax paper or wax-coated freezer wrap
- Thin, semi-permeable wrap

**⚠ CAUTION:** Do not keep beverage cans or plastic food containers in the freezer compartment. They may break or burst if they freeze.

## REFRIGERATOR SECTION

The shelves in your refrigerator are adjustable to meet your individual storage needs. Your model may have full or split shelves.

Adjusting the shelves to fit different heights of items will make finding the exact item you want easier. Doing so will also reduce the amount of time the refrigerator door is open which will save energy.

**IMPORTANT:** Do not clean glass shelves with warm water while they are cold. Shelves may break if exposed to sudden temperature changes or impact.

**CAUTION:** Glass shelves are heavy. Use special care when removing them.

### ADJUSTING SHELVES (FULL SHELF)

**To remove a shelf** — Lift up the back of the shelf slightly, then pull the shelf forward and out.

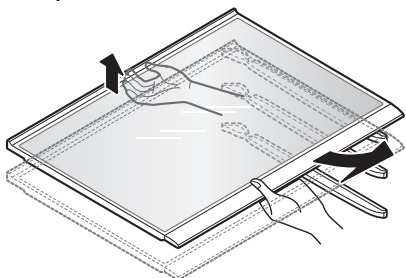

**To reinstall a shelf** — Slide the shelf into the guides until it stops.

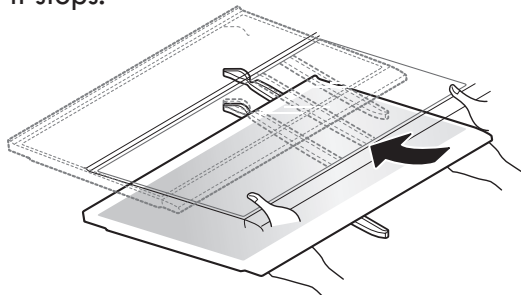

### HUMIDITY CONTROLLED CRISPER

The crispers provide fresher tasting fruit and vegetables by letting you easily control humidity inside the drawer.

You can control the amount of humidity in the moisture-sealed crispers by adjusting the control to any setting between **VEGETABLE** and **FRUIT**.

- **VEGETABLE** keeps moist air in the crisper for best storage of fresh, leafy vegetables.
- **FRUIT** lets moist air out of the crisper for best storage of fruit.

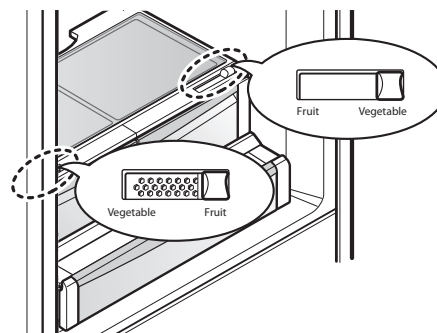

### REMOVING THE HUMIDITY CONTROLLED CRISPER

1. To remove, pull the drawer out to full extension.
2. Lift the front of the crisper up, then pull it straight out.

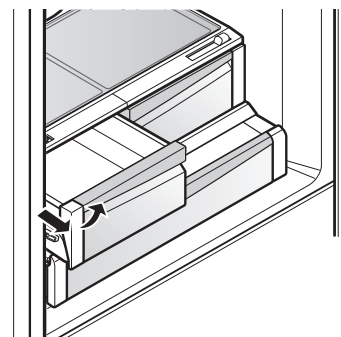

3. To install, slightly tilt up the front, insert the drawer into the frame and push it back into place.

### To remove the glass

1. Lift up the glass under the crisper cover.
2. Pull the glass up and out.

**NOTE:** Pantry drawer not shown for clarity.

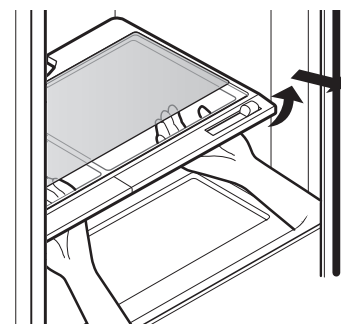

### PANTRY DRAWER

This drawer can be used for large party trays, deli items and beverages. (This drawer should not be used for vegetables that require high humidity.)

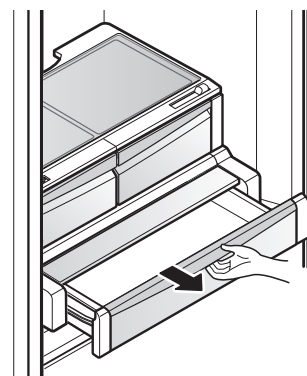

## DOOR BINS

The door bins are removable for easy cleaning and adjustment.

1. To remove a bin, simply lift the bin up and pull straight out.

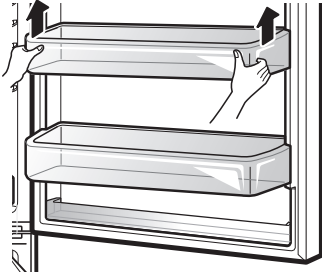

2. To replace a bin, slide it in above the desired support and push down until it snaps into place.

**NOTE:** Some bins may vary in appearance and will only fit in one location.

## DAIRY BIN

1. To remove the Dairy Bin, simply lift up and pull out.

2. To replace the Dairy Bin, slide it in above the desired support slots and push down until it stops.

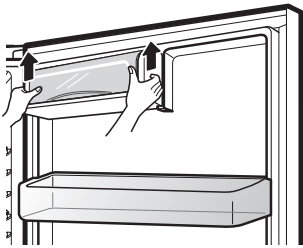

## FREEZER SECTION

\* The appearance of the actual product may differ depending on the model.

### ICE BIN

1. Pull the Freezer Drawer and the Pullout Drawer out as far as possible to remove the Extra Ice Bin.
2. Gently lift and pull out the ice bin.
3. To replace, pull both drawers out as far as possible, and set the bin in its correct position in the Pullout Drawer. Close the Pullout Drawer and then the Freezer Drawer.

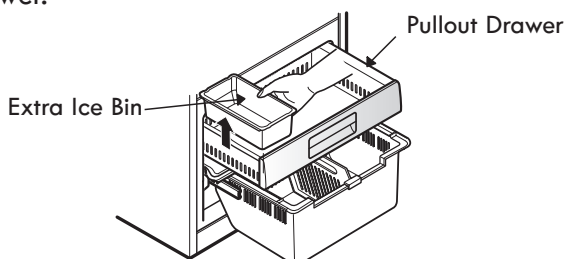

## PULLOUT DRAWER

1. To remove, pull the drawer out to full extension. Lift the top drawer up and out.

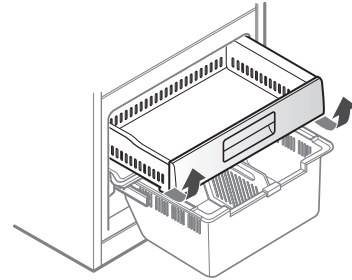

2. To replace, follow the same instructions in backwards.

## DURABASE DIVIDER

The Durabase divider allows you to organize the Durabase area into sections. It can be adjusted from side to side to accommodate items of different sizes.

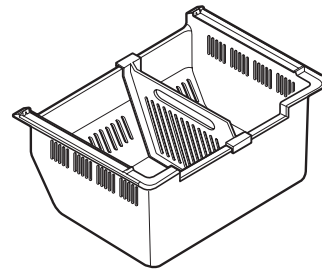

**⚠ WARNING:** If the Durabase divider is removed, there is enough open space for children or pets to crawl inside. To prevent accidental child and pet entrapment or suffocation risk, **DO NOT** allow children or pets to touch or go near the drawer.



## CARE AND CLEANING

### **! WARNING**



#### **Explosion Hazard**

Use non-flammable cleaner. Failure to do so can result in fire, explosion, or death.

Both the refrigerator and freezer sections defrost automatically; however, clean both sections about once a month to prevent odors. Wipe up spills immediately.

#### **GENERAL CLEANING TIPS**

- Unplug the refrigerator or disconnect power.
- Remove all removable parts, such as shelves, crispers, etc. Refer to sections in *Using Your Refrigerator* for removal instructions.
- Use a clean sponge or soft cloth and a mild detergent in warm water. Do not use abrasive or harsh cleaners.
- Hand wash, rinse and dry all surfaces thoroughly.
- Plug in the refrigerator or reconnect power.

#### **EXTERIOR**

Waxing external painted metal surfaces helps provide rust protection. Do not wax plastic parts. Wax painted metal surfaces at least twice a year using appliance wax (or auto paste wax). Apply wax with a clean, soft cloth.

For products with a stainless steel exterior, use a clean sponge or soft cloth and a mild detergent in warm water. Do not use abrasive or harsh cleaners. Dry thoroughly with a soft cloth.

**INSIDE WALLS** (allow the freezer to warm up so the cloth will not stick)

To help remove odors, you can wash the inside of the refrigerator with a mixture of baking soda and warm water. Mix 2 tablespoons of baking soda to 1 quart of water (26 g soda to 1 liter water.) Be sure the baking soda is completely dissolved so it does not scratch the surfaces of the refrigerator.

**! CAUTION:** While cleaning the inside of the refrigerator, do not spray water.

#### **DOOR LINERS AND GASKETS**

Use a clean sponge or soft cloth and a mild detergent in warm water. Do not use cleaning waxes, concentrated detergents, bleaches, or cleaners containing petroleum on plastic refrigerator parts.

#### **PLASTIC PARTS (Covers and Panels)**

Use a clean sponge or soft cloth and a mild detergent in warm water. Do not use window sprays, abrasive cleansers, or flammable fluids. These can scratch or damage the material.

#### **CONDENSER COILS**

Use a vacuum cleaner with an attachment to clean the condenser cover and vents. Do not remove the panel covering the condenser coil area.

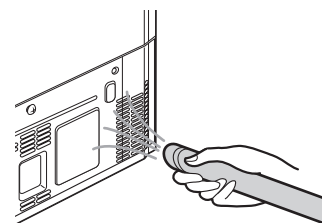

### LIGHT REPLACEMENT

#### **WARNING**

##### **Electrical Shock Hazard**

Before replacing a Compartment Lamp, either unplug the refrigerator or turn off power at the circuit breaker or fuse box.

**NOTE:** The refrigerator and freezer compartment lights have LED interior lighting, and service should be performed by a qualified technician.

### POWER INTERRUPTIONS

1. If the power will be out for 24 hours or less, keep all refrigerator doors closed to help foods stay cold and frozen.
2. If the power will be out for more than 24 hours, remove all frozen food and store it in a frozen food locker.

### WHEN YOU GO ON VACATION

**If you choose to leave the refrigerator on while you are away,** follow these steps to prepare your refrigerator before you leave.

1. Use up any perishables and freeze other items.
2. Turn off the icemaker and empty the ice bin.

**If you choose to turn the refrigerator off before you leave,** follow these steps.

1. Remove all food from the refrigerator.
2. Depending on your model, set the thermostat control (refrigerator control) to OFF. See the **Setting the Controls** section.
3. Clean the refrigerator, wipe it and dry well.
4. Tape rubber or wood blocks to the tops of both doors to prop them open far enough for air to get in. This stops odor and mold from building up.

### WHEN YOU MOVE

When you are moving your refrigerator to a new home, follow these steps to prepare it for the move.

1. Remove all food from the refrigerator and pack all frozen food in dry ice.
2. Unplug the refrigerator.
3. Clean, wipe and dry it thoroughly.
4. Take out all removable parts, wrap them well and tape them together so they do not shift and rattle during the move. Refer to the **Using your Refrigerator** section for removal instructions.
5. Depending on the model, raise the front of the refrigerator so it rolls easier OR screw in the leveling legs all the way so they do not scrape the floor. See the **Door Closing** section.
6. Tape the doors shut and tape the power cord to the refrigerator cabinet.

When you get to your new home, put everything back and refer to the **Refrigerator Installation** section for preparation instructions.

# CONNECTING THE WATER LINE

## BEFORE YOU BEGIN

This water line installation is not covered by the refrigerator warranty. Follow these instructions carefully to minimize the risk of expensive water damage.

Water hammer (water banging in the pipes) in house plumbing can cause damage to refrigerator parts and can lead to water leakage or flooding. Call a qualified plumber to correct water hammer before installing the water supply line to the refrigerator.

**⚠ CAUTION:** To prevent burns and product damage, only connect the refrigerator water line to a cold water supply.

If you use your refrigerator before connecting the water line, make sure the icemaker power switch is in the **OFF (O)** position.

**⚠ CAUTION:** Do not install the icemaker tubing in areas where temperatures fall below freezing.

## WATER PRESSURE

**A cold water supply.** The water pressure must be between 20 and 120 psi on models without a water filter and between 40 and 120 psi on models with a water filter.

If a **reverse osmosis water filtration system** is connected to your cold water supply, this water line installation is not covered by the refrigerator warranty. Follow the following instructions carefully to minimize the risk of expensive water damage.

If a **reverse osmosis water filtration system** is connected to your cold water supply, the water pressure to the reverse osmosis system needs to be a minimum of 40 to 60 psi (2.8 kgf/cm<sup>2</sup> ~ 4.2 kgf/cm<sup>2</sup>, less than 2.0~3.0 sec. to fill a cup of 7 oz capacity).

If the water pressure from the reverse osmosis system is less than 21 psi or 1.5 kgf/cm<sup>2</sup> (takes more than 4.0 sec to fill a cup of 7 oz capacity):

- Check to see if the sediment filter in the reverse osmosis system is blocked. Replace the filter if necessary.
- Allow the storage tank on the reverse osmosis system to refill after heavy usage.
- If the issue concerning water pressure from reverse osmosis remains, call a licensed, qualified plumber.
- All installations must be in accordance with local plumbing code requirements.

**⚠ CAUTION:** Wear eye protection during installation to prevent injury.

## WHAT YOU WILL NEED

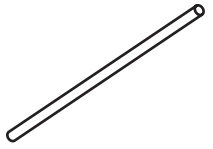
- **Copper Tubing**, 1/4 in. outer diameter, to connect the refrigerator to the water supply. Be sure both ends of the tubing are cut square. 
- To determine how much tubing you need: measure the distance from the water valve on the back of the refrigerator to the water supply pipe. Then, add 8 feet (2.4 m). Be sure there is sufficient extra tubing (about 8 feet [2.4 m] coiled into 3 turns of about 10 in. [25 cm] diameter) to allow the refrigerator to move out from the wall after installation.

- **Power drill.**
- **1/2 in. or adjustable wrench.**
- **Flat blade and Phillips head screwdrivers.**

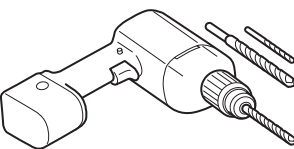
- **Two 1/4 in. outer diameter compression nuts and 2 ferrules (sleeves)** to connect the copper tubing to the shutoff valve and the refrigerator water valve. 

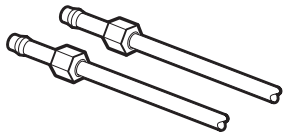
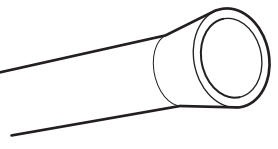
- If your existing copper water line has a flared fitting at the end, you will need an **adapter** (available at plumbing supply stores) to connect the water line to the refrigerator OR you can cut off the flared fitting with a tube cutter and then use a compression fitting.   

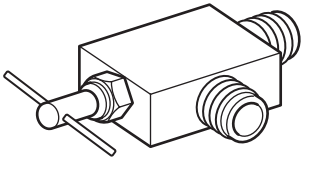
- **Shutoff valve to connect to the cold water line.** The shutoff valve should have a water inlet with a minimum inside diameter of 5/32 in. at the point of connection to the COLD WATER LINE. Saddle-type shutoff valves are included in many water supply kits. Before purchasing, make sure a saddle-type valve complies with your local plumbing codes. 

**NOTE:** A Self Piercing Saddle Type Water Valve should not be used.

## **⚠ WARNING**

### **Electrical Shock Hazard**

When using any electrical device (such as a power drill) during installation, be sure the device is battery powered, double insulated or grounded in a manner that will prevent the hazard of electric shock.

## INSTALLATION INSTRUCTIONS

Install the shutoff valve on the nearest frequently used drinking water line.

### 1. SHUT OFF THE MAIN WATER SUPPLY

Turn on the nearest faucet to relieve the pressure on the line.

### 2. CHOOSE THE VALVE LOCATION

Choose a location for the valve that is easily accessible. It is best to connect into the side of a vertical water pipe. When it is necessary to connect to a horizontal water pipe, make the connection to the top or side, rather than at the bottom, to avoid drawing off any sediment from the water pipe.

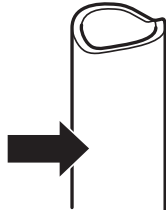

### 3. DRILL THE HOLE FOR THE VALVE

Drill a 1/4 in. hole in the water pipe using a sharp bit. Remove any burrs resulting from drilling the hole in the pipe. Be careful not to allow water to drain into the drill. Failure to drill a 1/4 in. hole may result in reduced ice production or smaller cubes.

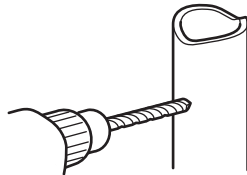

**NOTE:** The hookup line cannot be white, plastic tubing. Licensed plumbers must use only copper tubing (NDA tubing #49595 or #49599) or Cross Link Polyethylene (PEX) tubing.

### 4. FASTEN THE SHUTOFF VALVE

Fasten the shutoff valve to the cold water pipe with the pipe clamp.

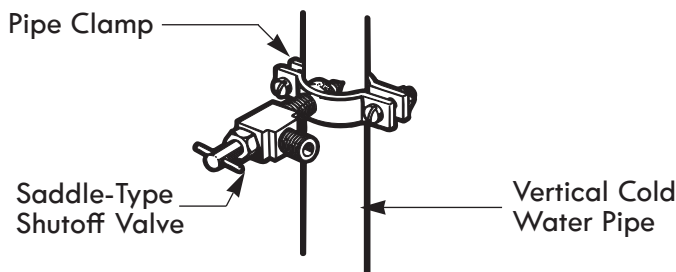

**NOTE:** Commonwealth of Massachusetts Plumbing Codes 248CMR shall be adhered to. Saddle valves are illegal and use is not permitted in Massachusetts. Consult with your licensed plumber.

### 5. TIGHTEN THE PIPE CLAMP

Tighten the clamp screws until the sealing washer begins to swell.

**NOTE:** Do not overtighten the clamp or you may crush the tubing.

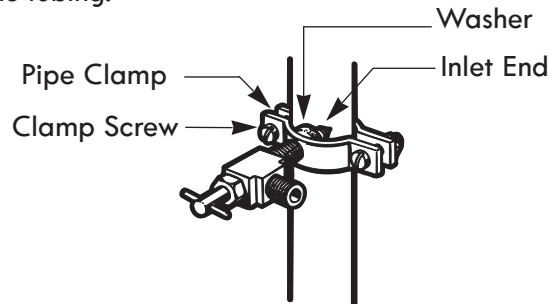

### 6. ROUTE THE TUBING

Route the tubing between the cold water line and the refrigerator.

Route the tubing through a hole drilled in the wall or floor (behind the refrigerator or adjacent base cabinet) as close to the wall as possible.

**NOTE:** Be sure there is sufficient extra tubing (about 8 feet coiled into 3 turns of about 10 in. diameter) to allow the refrigerator to move out from the wall after installation.

### 7. CONNECT THE TUBING TO THE VALVE

Place the compression nut and ferrule (sleeve) for copper tubing onto the end of the tubing and connect it to the shutoff valve. Make sure the tubing is fully inserted into the valve. Tighten the compression nut securely.

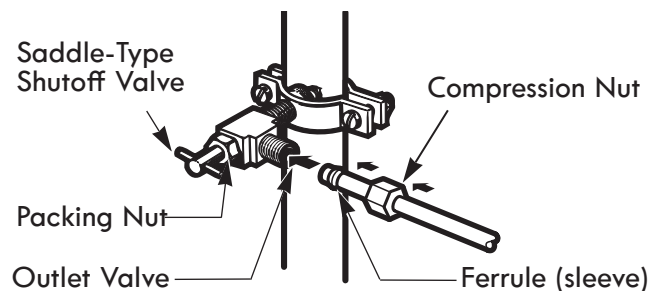

**NOTE:** Commonwealth of Massachusetts Plumbing Codes 248CMR shall be adhered to. Saddle valves are illegal and their use is not permitted in Massachusetts. Consult with your licensed plumber.

**8. FLUSH OUT THE TUBING**

Turn the main water supply on and flush out the tubing until the water is clear.

Shut the water off at the water valve after about one quart of water has been flushed through the tubing.

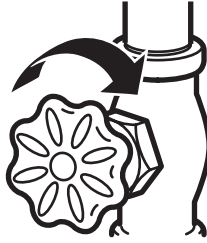
**9. CONNECT THE TUBING TO THE REFRIGERATOR**

**NOTE:** Before making the connection to the refrigerator, be sure that the refrigerator power cord is not plugged into the wall outlet.

1. Remove the plastic flexible cap from the water valve.
2. Place the compression nut and ferrule (sleeve) onto the end of the tubing as shown.
3. Insert the end of the copper tubing into the connection as far as possible. While holding the tubing, tighten the fitting.

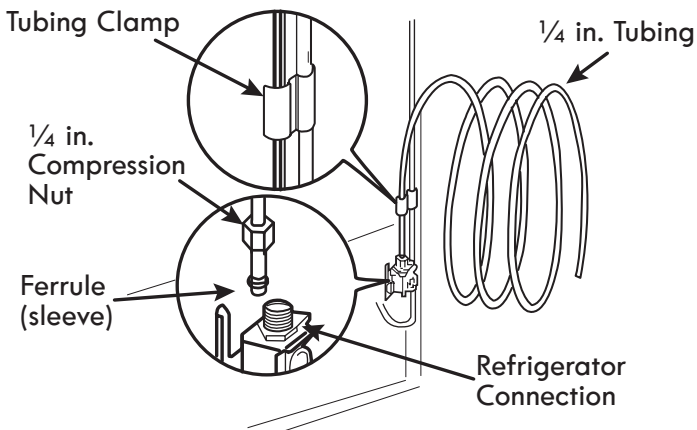
**10. TURN THE WATER ON AT THE SHUTOFF VALVE**

Tighten any connections that leak.

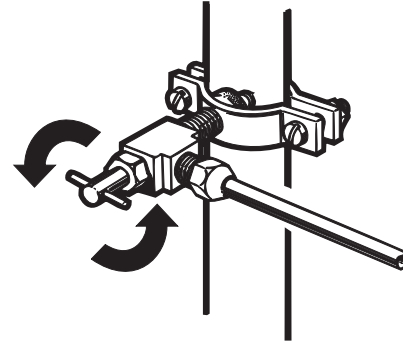

**⚠ CAUTION:** Check to see if leaks occur at the water line connections.

**11. PLUG IN THE REFRIGERATOR**

Arrange the coil of tubing so that it does not vibrate against the back of the refrigerator or against the wall. Push the refrigerator back to the wall.

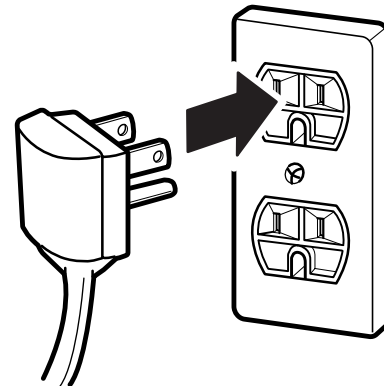
**12. START THE ICEMAKER**

Set the icemaker power switch to the **ON** position.

The icemaker will not begin to operate until it reaches its operating temperature of 15°F (−9°C) or below. It will then begin operation automatically if the icemaker power switch is in the **ON (I)** position.

# TROUBLESHOOTING GUIDE

Before conducting troubleshooting, make sure that the following basic requirements are met:

Service Flow	0.5 gpm (1.9 lpm)
Water Supply	Potable Water
Water Pressure	40-120 psi (138 - 827 kPa)
Operating Ambient Temperature Limits	55°F - 110°F
Electrical Ratings	115 Volts, 60 Hz, AC only, and fused at 15 or 20 amperes.

## COOLING

Problem	Possible Causes	Solutions
Refrigerator and Freezer section are not cooling.	The refrigerator control is set to OFF (some models).	Turn the control ON. Refer to the <b>Setting the Controls</b> section for proper temperature settings.
	Refrigerator is set to demo mode. 	Demo Mode allows the lights and control display to work normally while disabling cooling to save energy while on the showroom floor. Refer to the <b>Setting the Controls</b> section for instructions on how to disable Demo Mode.
	Refrigerator is in the defrost cycle.	During the defrost cycle, the temperature of each compartment may rise slightly. Wait 30 minutes and confirm the proper temperature has been restored once the defrost cycle has completed.
	Refrigerator was recently installed.	It may take up to 24 hours for each compartment to reach the desired temperature.
	Refrigerator was recently relocated.	If the refrigerator was stored for a long period of time or moved on its side, it is necessary for the refrigerator to stand upright for 24 hours before connecting it to power.
Cooling System runs too much.	Refrigerator is replacing an older model.	Modern refrigerators require more operating time but use less energy due to more efficient technology.
	Refrigerator was recently plugged in or power restored.	The refrigerator will take up to 24 hours to cool completely.
	Door opened often or a large amount of food / hot food was added.	Adding food and opening the door warms the refrigerator, requiring the compressor to run longer in order to cool the refrigerator back down. In order to conserve energy, try to get everything you need out of the refrigerator at once, keep food organized so it is easy to find, and close the door as soon as the food is removed. (Refer to the <b>Food Storage Guide</b> .)
	Doors are not closed completely.	Firmly push the doors shut. If they will not shut all the way, see the <b>Doors will not close completely or pop open</b> section in <b>Parts &amp; Features Troubleshooting</b> .
	Refrigerator is installed in a hot location.	The compressor will run longer under warm conditions. At normal room temperatures (70°F) expect your compressor to run about 40% to 80% of the time. Under warmer conditions, expect it to run even more often. The refrigerator should not be operated above 110°F.
	Condenser / back cover is clogged.	Use a vacuum cleaner with an attachment to clean the condenser cover and vents. Do not remove the panel covering the condenser coil area.

## COOLING

Problem	Possible Causes	Solutions
Refrigerator or Freezer section is too warm.	Refrigerator was recently installed.	It may take up to 24 hours for each compartment to reach the desired temperature.
	Air vents are blocked.	Rearrange items to allow air to flow throughout the compartment. Refer to the Airflow diagram in the Using Your Refrigerator section.
	Doors are opened often or for long periods of time.	When the doors are opened often or for long periods of time, warm, humid air enters the compartment. This raises the temperature and moisture level within the compartment. To lessen the effect, reduce the frequency and duration of door openings.
	Unit is installed in a hot location.	The refrigerator should not be operated in temperatures above 110F.
	A large amount of food or hot food was added to either compartment.	Adding food warms the compartment requiring the cooling system to run. Allowing hot food to cool to room temperature before putting it in the refrigerator will reduce this effect.
	Doors not closed correctly.	See the Doors will not close correctly or pop open section in Parts & Features Troubleshooting.
	Temperature control is not set correctly.	If the temperature is too warm, adjust the control one increment at a time and wait for the temperature to stabilize. Refer to the Setting the Controls section for more information.
	Defrost cycle has recently completed.	During the defrost cycle, the temperature of each compartment may rise slightly and condensation may form on the back wall. Wait 30 minutes and confirm the proper temperature has been restored once the defrost cycle has completed.
Interior moisture buildup.	Doors are opened often or for long periods of time.	When the doors are opened often or for long periods of time, warm, humid air enters the compartment. This raises the temperature and moisture level within the compartment. To lessen the effect, reduce the frequency and duration of door openings.
	Doors not closed correctly.	See the Doors will not close correctly section in the Troubleshooting section.
	Weather is humid.	Humid weather allows additional moisture to enter the compartments when the doors are opened leading to condensation or frost. Maintaining a reasonable level of humidity in the home will help to control the amount of moisture that can enter the compartments.
	Defrost cycle recently completed.	During the defrost cycle, the temperature of each compartment may rise slightly and condensation may form on the back wall. Wait 30 minutes and confirm that the proper temperature has been restored once the defrost cycle has completed.
	Food is not packaged correctly.	Food stored uncovered or unwrapped, and damp containers can lead to moisture accumulation within each compartment. Wipe all containers dry and store food in sealed packaging to prevent condensation and frost.

## COOLING

Problem	Possible Causes	Solutions
Food is freezing in the refrigerator compartment.	Food with high water content was placed near an air vent.	Rearrange items with high water content away from air vents.
	Refrigerator temperature control is set incorrectly.	If the temperature is too cold, adjust the control one increment at a time and wait for the temperature to stabilize.
	Refrigerator is installed in a cold location.	When the refrigerator is operated in temperatures below 41°F (5°C), food can freeze in the refrigerator compartment. The refrigerator should not be operated in temperatures below 55°F (13°C).
Frost or ice crystals form on frozen food (outside of package).	Door is opened frequently or for long periods of time.	When the doors are opened often or for long periods of time, warm, humid air enters the compartment. This raises the temperature and moisture level within the compartment. Increased moisture will lead to frost and condensation. To lessen the effect, reduce the frequency and duration of door openings.
	Door is not closing properly.	Refer to the <b>Doors will not close correctly or pop open</b> section in the Troubleshooting section.
Refrigerator or Freezer section is too cold.	Incorrect temperature control settings.	If the temperature is too cold, adjust the control one increment at a time and wait for the temperature to stabilize. Refer to the <b>Setting the Controls</b> section for more information.
Frost or ice crystals on frozen food (inside of sealed package).	Condensation from food with a high water content has frozen inside of the food package.	This is normal for food items with a high water content.
	Food has been left in the freezer for a long period of time.	Do not store food items with high water content in the freezer for a long period of time.
Items in the Cheese & Butter and Condiment bins are not as cool as other items in the refrigerator.	The Cheese & Butter and Condiment bins will be slightly warmer than the refrigerator compartment.	This is normal. Items that you would like to keep cooler should be stored in the refrigerator section.



## ICE &amp; WATER

Problem	Possible Causes	Solutions
Icemaker is not making enough ice.	Demand exceeds ice storage capacity.	The icemaker will produce approximately 70~210 cubes in a 24 hour period.
	House water supply is not connected, valve is not turned on fully, or valve is clogged.	Connect the refrigerator to a cold water supply with adequate pressure and turn the water shutoff valve fully open.  If the problem persists, it may be necessary to contact a plumber.
	Water filter has been exhausted.	It is recommended that you replace the water filter: <ul style="list-style-type: none"> <li>• Approximately every six months.</li> <li>• When the water filter indicator turns on.</li> <li>• When the water dispenser output decreases.</li> <li>• When the ice cubes are smaller than normal.</li> </ul>
	Low house water supply pressure.	The water pressure must be between 20 and 120 psi on models without a water filter and between 40 and 120 psi on models with a water filter.
	Reverse Osmosis filtration system is used.	Reverse osmosis filtration systems can reduce the water pressure below the minimum amount and result in icemaker issues. (Refer to <b>Water Pressure</b> section.)
	Tubing connecting refrigerator to house supply valve is kinked.	Straighten or repair the water supply line and arrange it to prevent future kinks.
	Doors are opened often or for long periods of time.	If the doors of the unit are opened often, ambient air will warm the refrigerator which will prevent the unit from maintaining the set temperature. Lowering the refrigerator temperature can help, as well as not opening the doors as frequently.
	Doors are not closed completely.	If the doors are not properly closed, ice production will be affected. See the <b>Doors will not close completely or pop open</b> section in <b>Parts &amp; Features Troubleshooting</b> for more information.
	The temperature setting for the freezer is too warm.	The recommended temperature for the freezer compartment for normal ice production is 0°F. If the freezer temperature is warmer, ice production will be affected.

## ICE &amp; WATER

Problem	Possible Causes	Solutions
Icemaker is not making ice.	Refrigerator was recently installed or icemaker recently connected.	It may take up to 24 hours for each compartment to reach the desired temperature and for the icemaker to begin making ice.
	Icemaker not turned on.	Locate the icemaker ON/OFF switch and confirm that it is in the ON (I) position.
	The ice detecting sensor is obstructed.	Foreign substances or frost on the ice-detecting sensor can interrupt ice production. Make sure that the sensor area is clean at all times for proper operation.
	The refrigerator is not connected to a water supply or the supply shutoff valve is not turned on.	Connect the refrigerator to the water supply and turn the water shutoff valve fully open.
	Icemaker shutoff (arm or sensor) obstructed.	If your icemaker is equipped with an ice shutoff arm, make sure that the arm moves freely. If your icemaker is equipped with the electronic ice shutoff sensor, make sure that there is a clear path between the two sensors.
	Reverse osmosis water filtration system is connected to your cold water supply.	Reverse osmosis filtration systems can reduce the water pressure below the minimum amount and result in icemaker issues. (Refer to the <b>Water Pressure</b> section.)
Ice has bad taste or odor.	Water supply contains minerals such as sulfur.	A water filter may need to be installed to eliminate taste and odor problems. <b>NOTE:</b> In some cases, a filter may not help. It may not be possible to remove all minerals / odor / taste in all water supplies.
	Icemaker was recently installed.	Discard the first few batches of ice to avoid discolored or bad tasting ice.
	Ice has been stored for too long.	Ice that has been stored for too long will shrink, become cloudy, and may develop a stale taste. Throw away old ice and make a new supply.
	The food has not been stored properly in either compartment.	Rewrap the food. Odors may migrate to the ice if food is not wrapped properly.
	The interior of the refrigerator needs to be cleaned.	See the <b>Care and Cleaning</b> section for more information.
	The ice storage bin needs to be cleaned.	Empty and wash the bin (discard old cubes). Make sure that the bin is completely dry before reinstalling it.
Icemaker is making too much ice.	Icemaker shutoff (arm/sensor) is obstructed.	Empty the ice bin. If your icemaker is equipped with an ice shutoff arm, make sure that the arm moves freely. If your icemaker is equipped with the electronic ice shutoff sensor, make sure that there is a clear path between the two sensors. Reinstall the ice bin and wait 24 hours to confirm proper operation.

## NOISE

Problem	Possible Causes	Solutions
Clicking	The defrost control will click when the automatic defrost cycle begins and ends. The thermostat control (or refrigerator control on some models) will also click when cycling on and off.	Normal Operation
Rattling	Rattling noises may come from the flow of refrigerant, the water line on the back of the unit, or items stored on top of or around the refrigerator.	Normal Operation
	Refrigerator is not resting solidly on the floor.	Floor is weak or uneven or leveling legs need to be adjusted. See the <b>Door Alignment</b> section.
	Refrigerator with linear compressor was jarred while running.	Normal Operation
Whooshing	Evaporator fan motor is circulating air through the refrigerator and freezer compartments.	Normal Operation
	Air is being forced over the condenser by the condenser fan.	Normal Operation
Gurgling	Refrigerant flowing through the cooling system.	Normal Operation
Popping	Contraction and expansion of the inside walls due to changes in temperature.	Normal Operation
Sizzling	Water dripping on the defrost heater during a defrost cycle.	Normal Operation
Vibrating	If the side or back of the refrigerator is touching a cabinet or wall, some of the normal vibrations may make an audible sound.	To eliminate the noise, make sure that the sides and back cannot vibrate against any wall or cabinet.
Dripping	Water running into the drain pan during the defrost cycle.	Normal Operation
Pulsating or High-Pitched Sound	Your refrigerator is designed to run more efficiently to keep your food items at the desired temperature. The high efficiency compressor may cause your new refrigerator to run longer than your old one, but it is still more energy efficient than previous models. While the refrigerator is running, it is normal to hear a pulsating or high-pitched sound.	Normal Operation

## PARTS &amp; FEATURES

Problem	Possible Causes	Solutions
Doors will not close correctly or pop open.	Food packages are blocking the door open.	Rearrange food containers to clear the door and door shelves.
	Ice bin, crisper cover, pans, shelves, door bins, or baskets are out of position.	Push bins all the way in and put crisper cover, pans, shelves and baskets into their correct positions. See the <b>Using Your Refrigerator</b> section for more information.
	The doors were removed during product installation and not properly replaced.	Remove and replace the doors according to the <b>Removing and Replacing Refrigerator Handles and Doors</b> section.
	Refrigerator is not leveled properly.	See <b>Door Alignment</b> in the <b>Refrigeration Installation</b> section to level refrigerator.
Doors are difficult to open.	The gaskets are dirty or sticky.	Clean the gaskets and the surfaces that they touch. Rub a thin coat of appliance polish or kitchen wax on the gaskets after cleaning.
	Door was recently closed.	When you open the door, warmer air enters the refrigerator. As the warm air cools, it can create a vacuum. If the door is hard to open, wait one minute to allow the air pressure to equalize, then see if it opens more easily.
Refrigerator wobbles or seems unstable.	Leveling legs are not adjusted properly.	Refer to the <b>Leveling and Door Alignment</b> section.
	Floor is not level.	It may be necessary to add shims under the leveling legs or rollers to complete installation.
Lights do not work.	LED interior lighting failure.	The refrigerator compartment lamp is LED interior lighting, and service should be performed by a qualified technician. Refer to the <b>Light Bulb Replacement</b> section.
Refrigerator has an unusual odor.	The Air Filter may need to be set to the MAX setting or replaced.	Set the Air Filter to the MAX setting. If the odor does not go away within 24 hours, the filter may need to be replaced. See the <b>Replacing the Air Filter</b> section for replacement instructions.
The interior of the refrigerator is covered with dust or soot.	The refrigerator is located near a fire source, such as a fireplace, chimney or candle.	Make sure that the refrigerator is not located near a fire source, such as a fireplace, chimney or candle.

# Diagnostics

Should you experience any problems with your refrigerator, it has the capability of transmitting data via your telephone to the Diagnostics Team. This gives you the capability of speaking directly to our trained specialists. The specialist records the data transmitted from your machine and uses it to analyze the issue, providing a fast and effective diagnosis.

If you experience problems with your refrigerator, call in the U.S.A. call 1-844-553-6667 Only use the Diagnostics feature when instructed to do so by the Diagnostics Team. The transmission sounds that you will hear are normal and sound similar to a fax machine.

Diagnostics cannot be activated unless your refrigerator is connected to power. If your refrigerator is unable to turn on, then troubleshooting must be done without using Diagnostics.

## Using Diagnostics

**NOTE:** For best results, use Diagnostics with a landline phone.

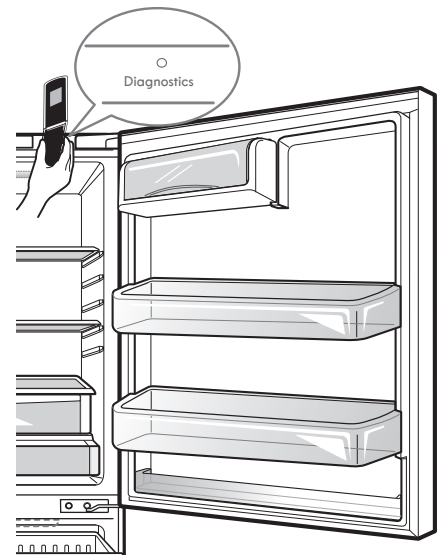

**HOLD** the mouthpiece of your phone in front of the speaker that is located on the right hinge of the refrigerator door, when instructed to do so by the call center. Hold the phone no more than one inch from (but not touching) the speaker.



**PUSH** and hold the Freezer Temp button for three seconds while continuing to hold your phone to the speaker.



**LISTEN** for three beeps. After you hear the three beeps, release the Freezer Temp button. Keep the phone in place until the tone transmission has finished. This takes about 3 seconds, and the display will count down the time. Once the countdown is over and the tones have stopped, resume your conversation with the specialist, who will then be able to assist you in using the information transmitted for analysis.

### NOTE:

- For best results, do not move the phone while the tones are being transmitted.
- If the call center agent is not able to get an accurate recording of the data, you may be asked to try again.

### NOTE:

- Call quality differences by region may affect the function.
- Use the home telephone for better communication performance, resulting in better service.
- Bad call quality may result in poor data transmission from your phone to the machine, which could cause Diagnostics to not work properly.

# Kenmore®

## Customer Care Hotline

To schedule in-home repair service  
or order replacement parts

Para pedir servicio de reparación  
a domicilio, y ordenar piezas

# 1-844-553-6667

[www.kenmore.com](http://www.kenmore.com)

