

# OWNER'S MANUAL TOP FREEZER REFRIGERATOR

Please read this manual carefully before operating your appliance and retain it for future reference.

Model Name\* = color number

LTCS20220\*

LTCS24223\*

LTNS20220\*

LTCS20120\*

GT66BP\*

GT58BP\*

GT57BP\*K

LTWS24223\*

LTCS20020\*

LT57BPSX



AFN75754512

P/No. MFL67527912-8

[www.lg.com](http://www.lg.com)

Copyright © 2018-2019 LG Electronics Inc .All Rights Reserved.

# TABLE OF CONTENTS

<b>Important Safety Instructions</b>	<b>2-3</b>	<b>Refrigerator Care and Cleaning</b>	<b>18-19</b>
Requirements for Ground Connection	3	Refrigerator Cleaning	18
		Outside	18
		Inside	18
<b>Parts and Features</b>	<b>4</b>	Door Lining & Gaskets	18
		Plastic Parts (Covers and Panel)	18
		Back Cover	18
<b>Refrigerator Installation</b>	<b>5-11</b>	Replacing Refrigerator Lights	18
Unpacking	5	Power Interruptions	18
Installation	5	When Going on Vacation	18
How to remove and Install the Refrigerator Doors	6-7	When Moving	19
How to reverse and Install the Refrigerator Doors	8-11		
Closing and Aligning the Doors	11	<b>About the Automatic Ice Maker</b>	<b>19</b>
<b>Using your Refrigerator</b>	<b>12-16</b>	<b>Connecting the Water Line</b>	<b>20-22</b>
Ensuring Proper Air Circulation	12		
Adjusting the Controls	12	<b>Troubleshooting Guide</b>	<b>22-26</b>
Adjusting Control Settings	13		
Food Storage Guide	13	<b>Smart Diagnosis™</b>	<b>27</b>
Refrigerator Shelves	14	<b>Door Alarm</b>	<b>27</b>
Pantry Drawer	14		
Ice Tray	15	<b>Warranty</b>	<b>28-32</b>
Humidity Controlled Crispers	15		
Door Bins	15	<b>Spanish Version</b>	<b>34</b>
Dairy Bin	15	<b>French Version</b>	<b>66</b>
Water Dispenser	16		
Automatic Icemaker	16		
<b>Water Filter</b>	<b>17</b>		

# IMPORTANT SAFETY INSTRUCTIONS

## SAFETY MESSAGES

This manual contains several important safety notices. Always read and obey all of the following safety messages.



This is the safety alert symbol. This symbol is a warning to potential dangers that could cause death, injury or damage to you, others or the product. All safety messages will follow after this warning symbol and the word "DANGER", "CAUTION" or "WARNING". These words mean:

**▲ DANGER**

You may be killed or suffer fatal damage if you do not follow instructions.

**▲ WARNING**

You may be killed or seriously injured if you do not follow instructions.

**▲ CAUTION**

Indicates a potentially hazardous situation which, if not avoided, may result in minor injury or damage to the product.

All safety messages inform you of potential danger, advise you on how to reduce the risk of injury and tell you what can occur if the instructions are not followed.

### ▲ WARNING

To reduce the risk of fire, electrical shock or personal injury, the following precaution measures should be followed:

- Keep ventilation openings, in the appliance enclosure or in the built-in structure, clear of obstruction.
- Do not use mechanical devices or other means to accelerate the defrosting process, other than those recommended by the manufacturer.
- Do not use electrical appliances inside the food storage compartments of the appliance, unless they are of the type recommended by the manufacturer.
- Do not store explosive substances such as aerosol cans with a flammable propellant in this appliance.
- Do not light a candle to remove odors in the refrigerator.
- In the event of a gas leak (propane/LPG), ensure the area is adequately ventilated and contact an authorized service center before resuming use. Do not touch the refrigerator or power cord of the refrigerator.
- NEVER disconnect the refrigerator by pulling the power cord, always grip the plug firmly and disconnect it directly from the outlet.
- Immediately repair or replace all faulty or damaged service cables. Do not use cords that have cracks or abrasion damage on the length of the cord or on the plug.
- When moving your refrigerator, take care not to roll over the electrical cord.
- **DO NOT** store or use gasoline or other combustible liquids or vapors in proximity with this or any other electrical appliance.
- **DO NOT** permit children to climb, stand or swing from the doors or shelves of the refrigerator. This can cause serious injury to them and damage to the product.
- Keep your fingers away from areas in which they can become caught, such as the doors, hinges and cabinets. Be careful closing the doors when children are near.
- Unplug the refrigerator before cleaning or repairing. **NOTE:** We strongly recommend that any repair services be performed by a qualified professional.
- Before replacing a burned-out light bulb, unplug the refrigerator or shut down the circuit breaker to avoid contact with a live wire (the bulb could break while being replaced). **NOTE:** Setting the control to the OFF position does not disconnect the power from the light bulb circuit.
- If disposing of a refrigerator, make sure the refrigerant and insulation foam are removed for proper disposal by a qualified servicer.
- If you release the refrigerant or throw away the insulation foam, you may be fined or imprisoned in accordance with the relevant environmental law. Insulation foam contains flammable blowing gas.
- Do not keep bottles in the freezer compartment, they could explode after freezing and cause damage.
- For your safety, this product should be properly grounded. Have a qualified professional check the electrical circuit and outlet to ensure a proper ground connection.
- Read all instructions before utilizing the product. Utilize this product only as explicitly expressed in this guide.
- Once the refrigerator is operating, avoid touching cold surfaces of the freezer with damp or wet hands; the skin could become adhered to these surfaces.
- In refrigerators with an automatic ice dispenser, avoid contact with moving parts of the ejector mechanism or with the heating mechanism that discharges the cubes. **DO NOT** place your fingers or hands in the ice dispenser mechanism while the refrigerator is connected.
- **DO NOT** refreeze foods which have already thawed. The Department of Agriculture of the United States, in your Bulletin of Home and Gardens No. 69 establishes that:  
"...You can refreeze food that has thawed if they contain ice crystals or are cold and below 40 °F (4 °C)".  
"...Ground beef, perishable food or seafood that is discolored or has an unpleasant odor should not be frozen or consumed. Consumption of melted ice cream should also be avoided. If the odor or color of food is questionable, discard it. The food may be dangerous to consume".  
"Partial thawing or refreezing reduces the quality of the food, especially fruit, vegetables and prepared meals. The quality of red meat is less affected than that of other foods. Use refrozen products as soon as possible in order to maintain their quality".
- Do not store any living animal inside your refrigerator.

### RISK OF FIRE AND FLAMMABLE MATERIALS



This appliance contains a small amount of isobutane refrigerant (R600a), which is combustible. When transporting and installing the appliance, care should be taken to ensure that no parts of the refrigerating circuit are damaged. Refrigerant squirting out of the pipes could ignite or cause an eye injury. If a leak is detected, avoid any naked flames or potential sources of ignition and air the room in which the appliance is standing for several minutes.

In order to avoid the creation of a flammable gas air mixture if a leak in the refrigerating circuit occurs, the size of the room in which the appliance may be sited depends on the amount of refrigerant used. The room must be 10.8 square feet (1 square meter) in size for every 8g of R600a refrigerant inside the appliance. The amount of refrigerant in your particular appliance is shown on the identification plate inside the appliance. Never start up an appliance showing any signs of damage. If in doubt, consult your dealer.

### KEEP THESE INSTRUCTIONS

## ⚠ CAUTION

This appliance is not intended for use by children, persons with physical or mental disabilities, persons with reduced sensory or mental capacity, or persons that lack experience or know-how, unless they have supervision or instruction in relation to the use of the appliance by the person responsible for their safety. Children should be supervised to assure that they do not play with the appliance.

## ⚠ DANGER: CHILDREN MAY BECOME TRAPPED

Children becoming trapped or suffocated is not a problem of the past. Discarded and abandoned refrigerators are a hazard, even if they remain there "for just a few days". If you would like to dispose of your old refrigerator, please follow the instructions below to prevent any accidents.

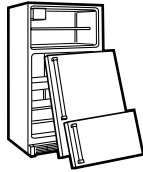

### BEFORE DISPOSING YOUR REFRIGERATOR OR FREEZER WHEN NO LONGER IN USE:

- Remove the doors and magnetic gaskets.
- Leave the shelves in place so that children cannot easily become stuck in them.

## CFC DISPOSAL

Your old refrigerator may have a cooling system that uses CFC's (chlorofluorocarbons). CFC affects the stratospheric layer of the ozone. If you decide to throw out your old refrigerator, ensure that CFC contaminants are properly disposed of by a qualified professional. If you intentionally remove the CFC refrigerant, you could be subject to fines or prison in accordance with environmental legislation in effect.

### ⚠ WARNING:

If you no longer require the use of this unit, contact the local authorities to dispose of this product in a safe way because it uses Cycle-Pentane or Pentane as foaming and flammable gases for insulation. Gases insulation material require special removal process. This product contains flammable insulation and refrigerant gases.

## REQUIREMENTS FOR GROUND CONNECTION

**IMPORTANT:** Attentively read the following.  
**TO CONNECT ELECTRICITY**

### ⚠ WARNING

**ELECTRICAL SHOCK HAZARD**  
**FOR YOUR PERSONAL SAFETY**, this appliance must be properly grounded. Have a qualified electrician check your wall outlet to ensure that the plug is grounded properly.

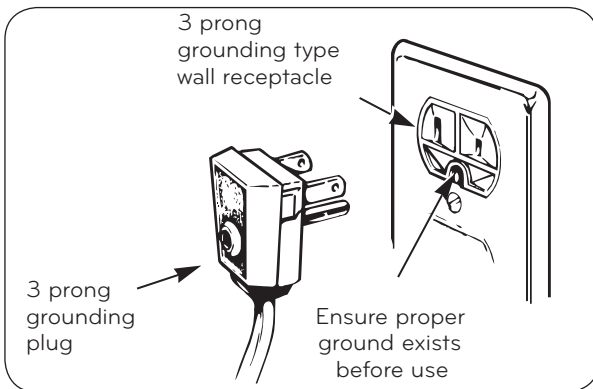

### RECOMMENDED GROUNDING METHOD

Your refrigerator must always be plugged to its own outlet which is adequately grounded. The energy current should only be 115 V ~ 60 Hz, AC or 127 V ~ 60 Hz, AC (according to the National rating), and fused at 15 or 20 A. This provides the best performance and prevents an overload which could cause a fire from the overheating of the cables. It is recommended that a separate circuit be used for this appliance, as well as a receptacle that cannot be disconnected with a switch.

Do not use an extension cable.

It is recommended use a separate circuit for this product as well as receptacle which can not be disconnected with a switch. Do not use extension cords or adapters ungrounded.

It is your responsibility and obligation to replace two-prong outlets with that of an adequately grounded three-prong outlet.

**Do not, under any circumstance, cut or extract the third prong from the plug.**

**NOTE:** Before installation, cleaning or replacing light bulbs, you must disconnect the appliance from the power source. When finished, plug the appliance back in and adjust the thermostat to the desired position.

### USE OF EXTENSION CABLES

**We do not recommend the use of extension cables.** However, if you still choose to utilize an extension cable, it is absolutely necessary that it is listed in the UL (in the United States) or CSA (in Canada), that it supports three-pronged plugs and that the electrical current support a minimum of 15 A and 120 V.

The use of an extension cable will increase the amount of space needed behind the refrigerator.

### ⚠ WARNING

#### REPLACING ELECTRICAL CABLE

If the power cord is damaged, it must be replaced by our service center or qualified LG technician to avoid any risk.

Do not extend or modify the power cord length, damage the power cord may cause electric shock or damage the unit.

## PARTS AND FEATURES

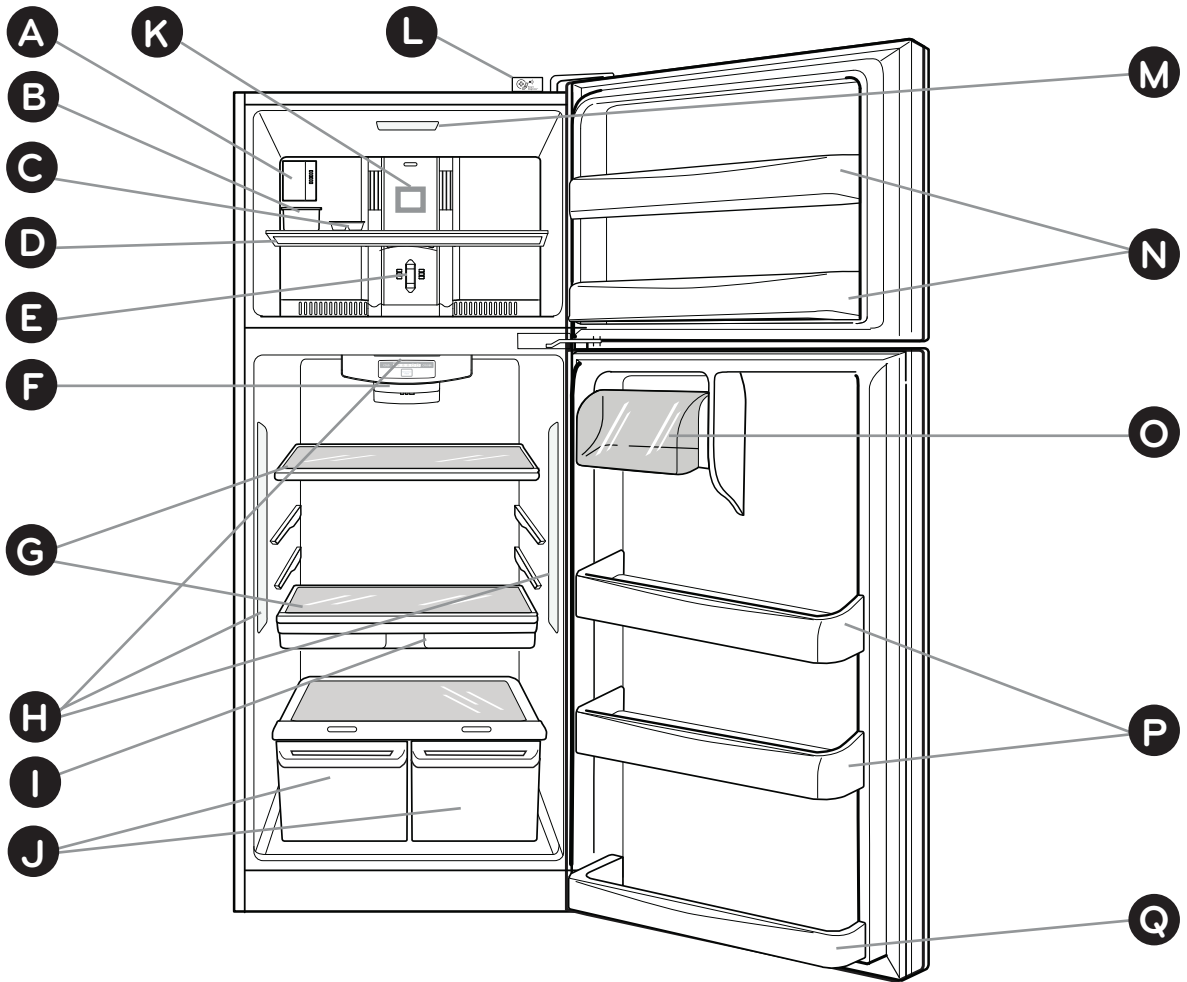

Use this page to become more familiar with the parts and features of your refrigerator. Page references are included for your convenience.

NOTE: This guide covers several models. The refrigerator you have purchased may have some or all of the items listed below. The locations of the features shown below may not match your model.

- |   |   |
|---|---|
| <b>A</b> Custom Cube Icemaker *           | <b>J</b> Crispers                           |
| <b>B</b> Ice Bin *                        | <b>K</b> F-Deco Duct                        |
| <b>C</b> Ice Tray *                       | <b>L</b> Smart Diagnosis™ *<br>Door Alarm * |
| <b>D</b> Freezer Shelf                    | <b>M</b> Freezer Light (LED)*               |
| <b>E</b> Freezer Temperature Control      | <b>N</b> Freezer Door Bins                  |
| <b>F</b> Refrigerator Temperature Control | <b>O</b> Dairy Bin                          |
| <b>G</b> Shelves                          | <b>P</b> Refrigerator Door Bins             |
| <b>H</b> Refrigerator Light (LED)*        | <b>Q</b> Refrigerator Door Bins*            |
| <b>I</b> Pantry Drawer*                   |   |

\* On some models

# REFRIGERATOR INSTALLATION

## ⚠ WARNING

### EXCESSIVE WEIGHT HAZARD

Use the assistance of two or more persons to move or install the refrigerator. Not following these instructions may cause injury to the back and other parts of the body.

### UNPACKING

Before installing your refrigerator, remove any tape or temporary stickers. Do not remove any stickers that feature warnings, the model serial number or the technical label of the product located on the back of the refrigerator.

**NOTE: Remove protective film on doors before plugging in the unit (on some models).**

To remove adhesive tape residue, rub it well with your fingers and a little liquid detergent. Clean with warm water and let dry.

Do not use sharp instruments, rubbing alcohol, flammable liquids or abrasive cleaning products to remove the adhesive tape or glue. These products can damage the surface of your refrigerator. For more information, see the section on "Important Safety Instructions".

The shelves come already installed in their factory position. Remove the shelves and replace them according to your spacing needs.

#### Moving Your Refrigerator:

Your refrigerator is extremely heavy. Make sure you protect the floor when moving your refrigerator for cleaning or servicing. Always pull your refrigerator straight out when moving it. Do not shift from side to side or "walk" the refrigerator when attempting to move it as this can cause damage to the floor.

## ⚠ WARNING

### EXPLOSION HAZARD



Keep all flammable materials and vapors (such as gasoline) away from the refrigerator. Not following these instructions may cause death, explosion or fire

### ⚠ CAUTION:

This appliance is intended to be used in household and similar applications such as: staff kitchen areas in shops, offices and other working environments; farm houses and by clients in hotels, motels and other residential type environments, bed and breakfast type environments, catering and similar non-retail applications.

## INSTALLATION

1. Avoid placing the unit near heat sources, direct sunlight, or humidity.
2. To avoid vibration, the unit should be leveled and placed on even floor. If needed, adjust the leveling screws to compensate for an unlevelled floor. The front should be slightly taller than the rear to ensure that the doors close properly. The leveling screws can easily be turned by slightly tilting the front of the refrigerator, turning the leveling screws clockwise (➡) to raise it and counter-clockwise (↩) to lower it.
3. Install the refrigerator in an area between 55 °F (13 °C) and 110 °F (43 °C). If the surrounding temperature is lower or higher than previously mentioned, it can adversely affect the unit.

**⚠ CAUTION:** Avoid placing the unit near heat sources, direct sunlight or humidity.

## ONCE INSTALLED

1. Carefully clean your refrigerator and remove and dust accumulated during shipping.
2. Install accessories such as the ice bin, door racks, shelves, etc., in their proper places. These are already packed to prevent any possible damage during shipping.
3. Leave your refrigerator on for 2 to 3 hours before storing food inside. Verify that there is a flow of cold air in the freezer compartment to ensure proper cooling. Your refrigerator is now ready for use.

### ⚠ WARNING:

- Take care when working with the hinges, base cover and stops, etc. You may injure yourself.
- DO not place your hands or any tools in the air vents, the base cover or in the bottom of the refrigerator. This may cause injury or electrical shock.

### Keep a Proper Distance from Adjacent Objects

Please keep the refrigerator at an adequate distance from other objects. Insufficient spacing can reduce the refrigerator's freezing efficiency and increase electricity consumption.

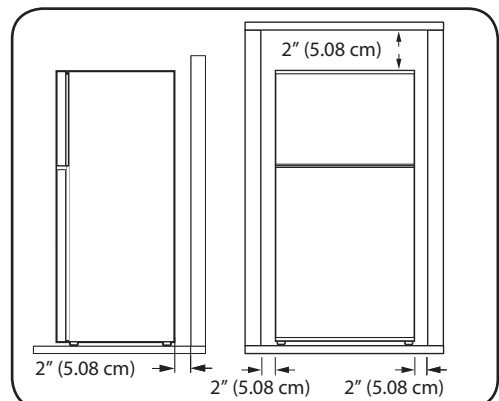

# REFRIGERATOR INSTALLATION

## HOW TO REMOVE AND INSTALL THE REFRIGERATOR DOORS

(For additional support on this topic, including helpful videos, please visit us at: [www.lg.com](http://www.lg.com)).

If entrance is less than 35 inches wide, the refrigerator's door will need to be removed.

**IMPORTANT:** Before starting, turn off and unplug the refrigerator. Remove all food and the racks from the doors.

### TOOLS YOU MIGHT NEED OR USE



### **⚠ WARNING**

#### **ELECTRICAL SHOCK HAZARD**

Before you begin, either unplug the refrigerator or turn off the power at the circuit breaker or fuse box. Remove food and any door rack from the refrigerator. Failure to do so could result in death or serious injury.

### 1. Removing Freezer Door

- Gently pry off the Top Hinge Cover with a flat head screwdriver and remove it. See Fig. 1.

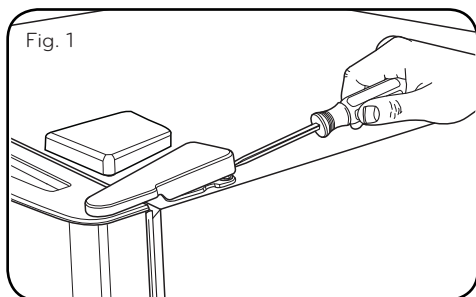

- Using 10 mm or 3/8 inch socket wrench, remove the three bolts and lift the Top Hinge (See Fig. 2). Set parts aside.

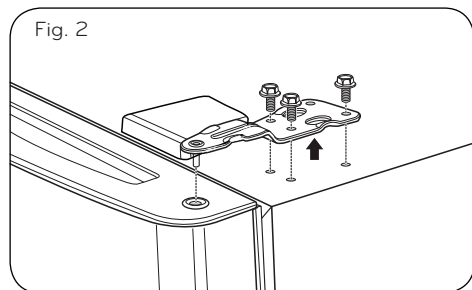

- Lift freezer door slightly and remove it (See Fig. 3) Set parts aside.

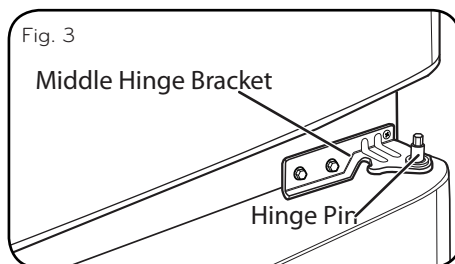

### 2. Removing Refrigerator Door

- Loosen and remove the two bolts and the screw to remove the middle hinge bracket from refrigerator housing (Figure 4). Set parts aside (Figure 5).

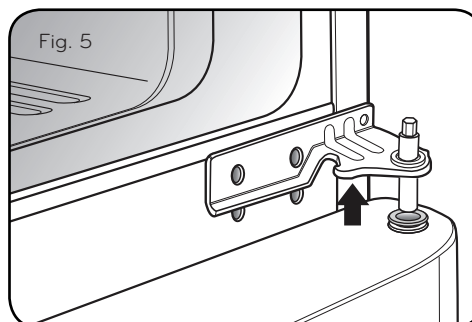
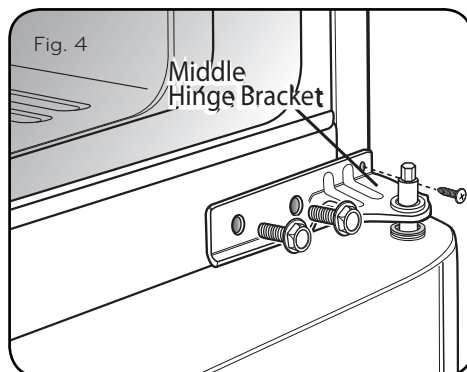

- Lift up door slightly and remove it (See Figure 6).

# REFRIGERATOR INSTALLATION

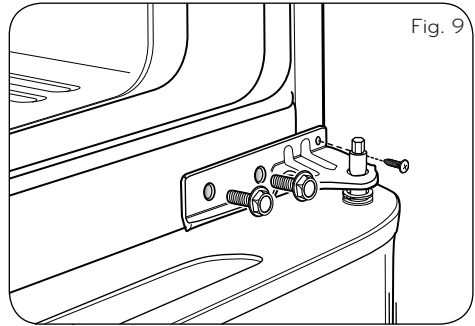
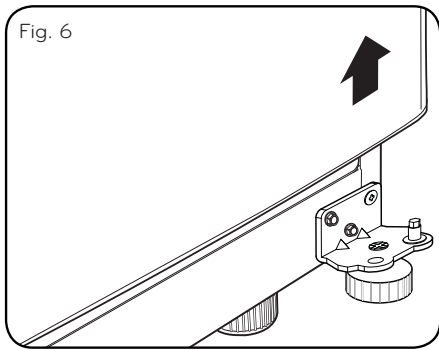

- To replace doors, begin with refrigerator door and then follow with freezer door.

## 4. Replacing Freezer Door

- Set the freezer door onto the Middle Hinge pin (Figure 10).
- Place upper hinge in the top of the freezer door and line up the hinge with the holes in top of refrigerator. Use the three bolts to fasten the hinge (See Figure 11).

## 3. Replacing Refrigerator Door

- Set door on Bottom Hinge Pin (See Figure 7).
- Place hinge pin of middle bracket inside the hinge pin insert on the top of the door (See Figure 8). Hold the door in place and line up the hinge with the holes in the refrigerator housing.

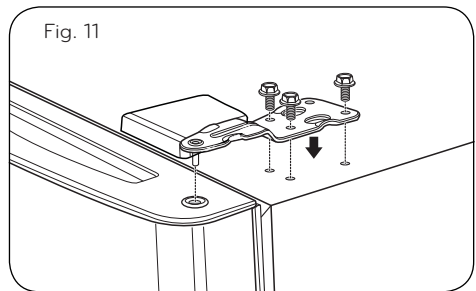
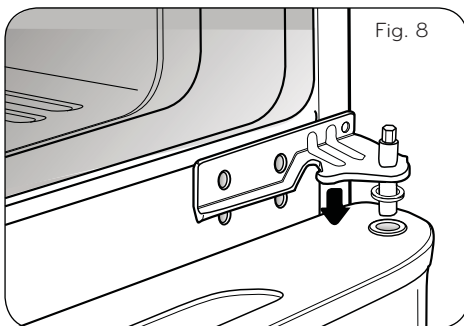
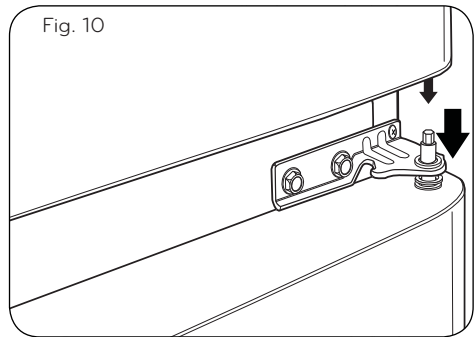
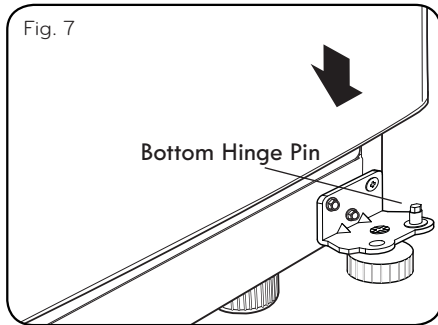

- Carefully, force the top hinge cover back into place over hinge (See Figure 12).

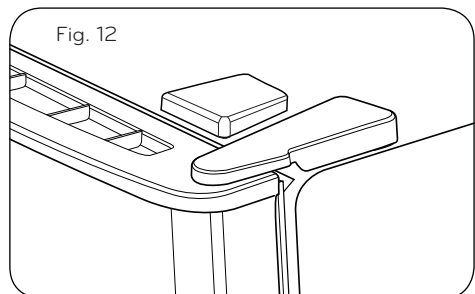



- Use the two bolts and the screw to refasten the middle hinge with the refrigerator housing. See Figure 9.

# REFRIGERATOR INSTALLATION

## HOW TO REVERSE AND INSTALL THE REFRIGERATOR DOORS (on some models)

You may find it more convenient to have the doors converted from the left opening type (factory installed) to the right opening type. Directions refer to the right side as the side on your right as you face the unit.

REVERSIBLE DOORS MODELS	TOOLS YOU MIGHT NEED OR USE		
LTCS20220* LTCS24223* LTNS20220* GT66BP* GT58BP* LTWS24223* LTCS20020* LT57BPSX	 1/4 in 3/8 in 10 mm Hex Socket Wrench	 Phillips Screwdriver No. 2	 Flat Head Screwdriver

### ⚠ WARNING

#### ELECTRICAL SHOCK HAZARD

Before you begin, either unplug the refrigerator or turn off the power at the circuit breaker or fuse box. Remove food and any door rack from the refrigerator. Failure to do so could result in death or serious injury.

### 1. Removing Freezer Door

Gently pry off the top hinge cover with a flat head screwdriver and remove.

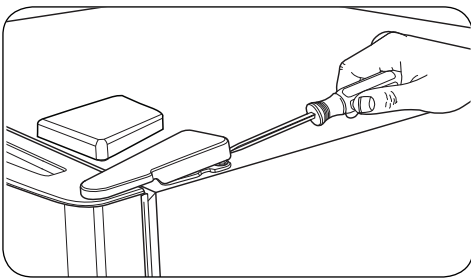

Using 10mm or 3/8 inch socket wrench, remove the three bolts and lift off the top hinge. Set parts aside

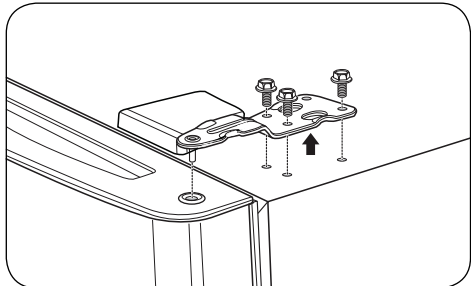

Slightly lift up the refrigerator door and remove it.

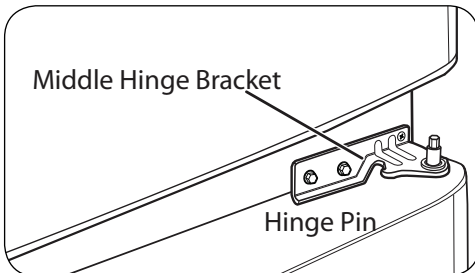

Turn the freezer door upside down on a non-scratch surface. Loosen the screw to remove the Door Closer/Stop and Hinge Pin Insert.

Move the Hinge Pin Insert Bracket to the other side of the door, keeping the same orientation, and move the Hinge Pin Insert into the hole on the left side of the bracket.

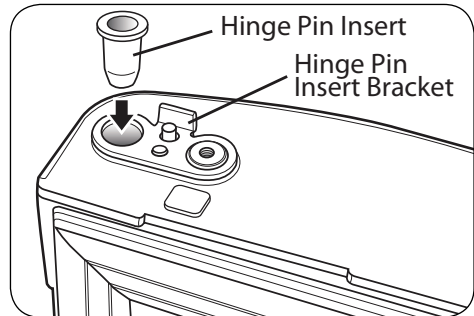

Reverse the Door Closer/Stop by flipping it over. Place it on top of the Hinge Pin Insert Bracket, and tighten both down with the screw.

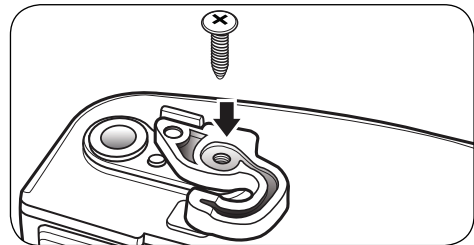

Pry off the cover on the top left side of the refrigerator to uncover the screw holes.

Set the freezer door and top hinge parts to the side and remove the refrigerator door.

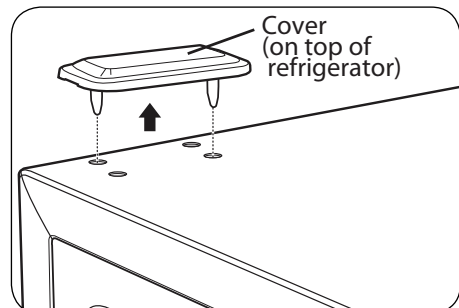

# REFRIGERATOR INSTALLATION

## 2. Reversing and Reinstalling Refrigerator Door

Using a 1/4" socket wrench, loosen and remove Hinge Pin from the Middle Hinge Bracket. Remove washer underneath the middle hinge and set aside.  
**NOTE:** At this point the door will be loose. Slightly lift the door and remove it.

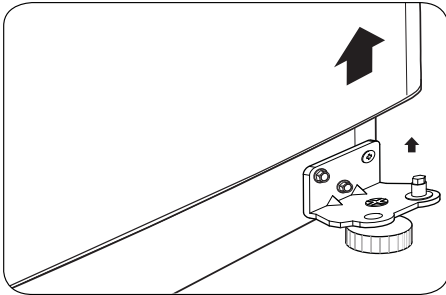
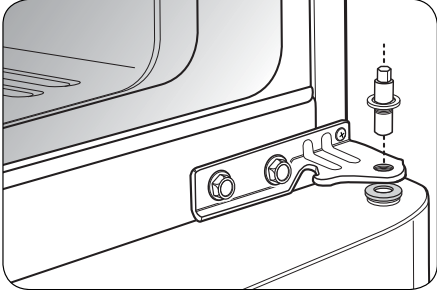

Loosen and remove the two bolts and use the Phillips head screwdriver to remove the Middle Hinge Bracket from the refrigerator housing. Set parts aside.

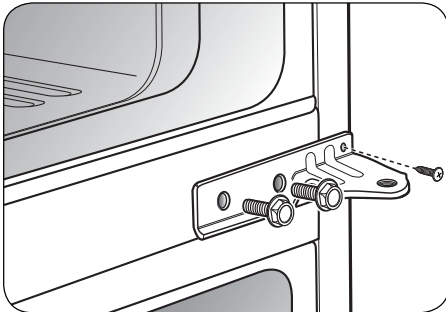

Remove the washer from the Bottom Hinge Pin. Using a 1/4" socket wrench, loosen and remove the Hinge Pin from the Bottom Hinge. Reattach the Hinge Pin to the opposite side of the hinge.

**NOTE:** This is easier to do while the hinge is still attached.

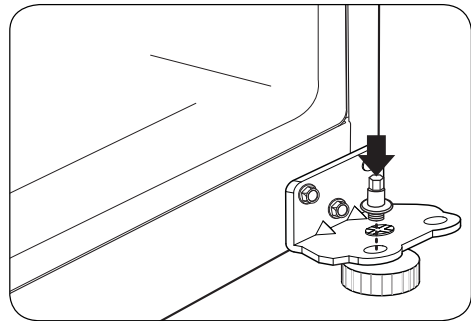
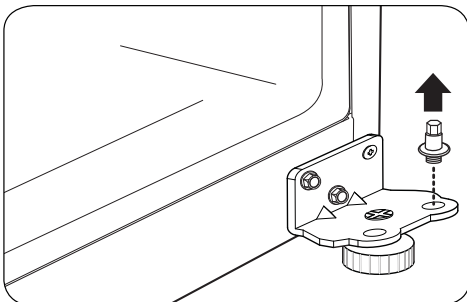

Using a 3/8" socket wrench with a 2-Inch extension and screwdriver, loosen the two bolts and one screw, and remove the Bottom Hinge from right side of the housing.

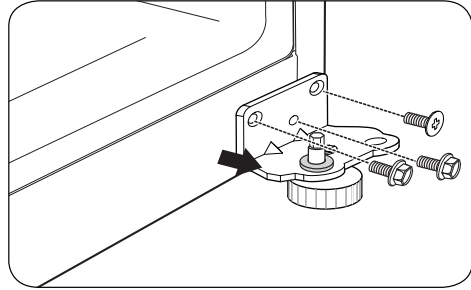

Remove the Decorative Caps on the bottom of the refrigerator housing. You will need these holes for the Bottom Hinge.

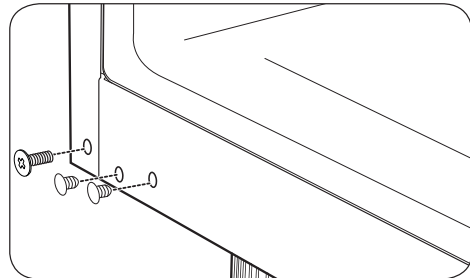

Move the Bottom Hinge to the left side of the housing, keeping the same orientation, and reattach with the two bolts and one screw. The flat screw must be placed on the exterior side of the hinge. Move the Decorative Bolt to the hole on the lower right side of the housing.

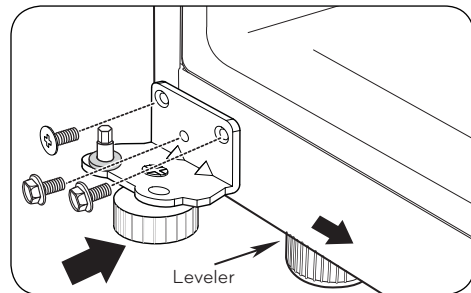

Turn the refrigerator door upside down on a nonscratching surface. Loosen the two screws to remove the Bottom Hinge Pin Insert Bracket with the Hingr Pin Insert.

**⚠ WARNING:** If you reinstall or replace doors, move the leveler to the opposite side.

**NOTE:** The leveler is only present on some models.

# REFRIGERATOR INSTALLATION

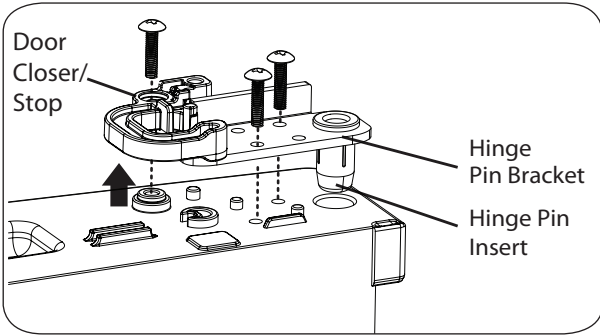

Reverse the Door Closer/Stop by flipping it over. Place it on top of the Hinge Pin Insert Bracket, and tighten both down with the screw. Tighten the Hinge Pin Bracket to the door.

**NOTE:** The Door Closer Stop is only presented on some models.

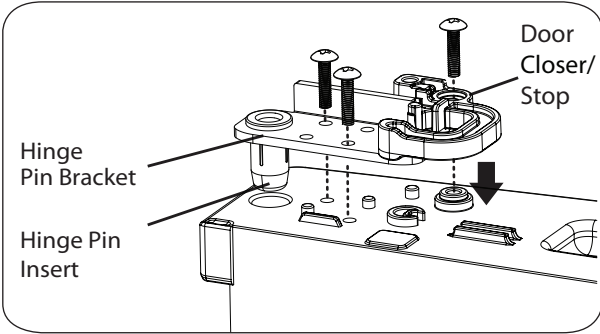

With a flat-head screwdriver, carefully pry off and remove the cover over the screw holes on the left side of refrigerator housing.

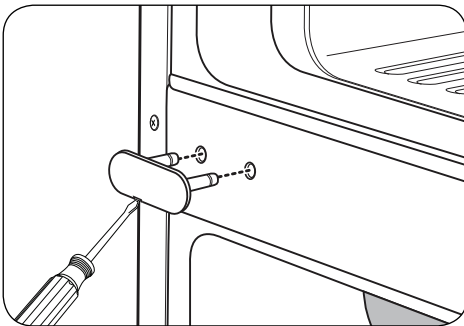

Remove the outer lower Decorative Screw from the housing at the area between the freezer and refrigerator doors. (You will need this hole for the Middle Hinge Bracket.)

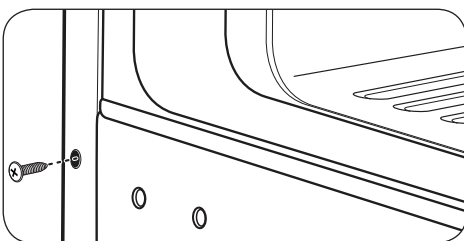

Flip the Middle Hinge Bracket, (flange will now be on top) position it on left side of the refrigerator and reattach with two bolts and a Phillips screwdriver. Place the refrigerator door down over the pin on the bottom hinge. Place the washer between the refrigerator door and middle hinge and re-attach Hinge Pin to Hinge Bracket with a 1/4" socket wrench.

**NOTE:** Bracket has been flipped, but Hinge Pin stays in the same orientation with its hexagonal end facing upward.

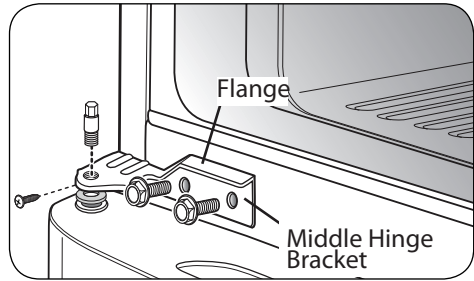

Insert the Decorative Screw into the outer hole on the right side of the housing. Attach cover on the right side. Cover is force-fitted.

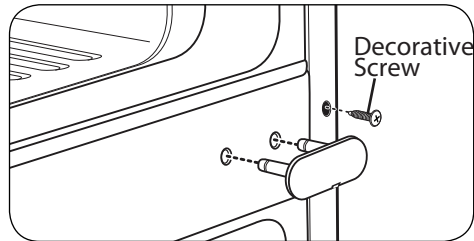

## REATTACHING THE DOORS

Place the freezer door down over the Hinge Pin on the Middle Hinge Pin Bracket.

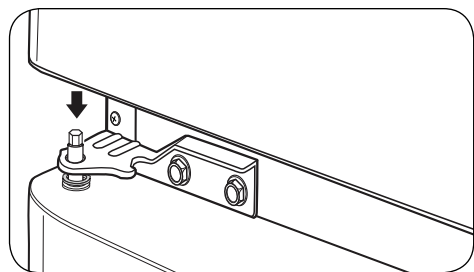

Place the Upper Hinge Pin on top of the freezer door and line up the Upper Hinge with holes on top of the refrigerator. Use the three bolts to replace the Hinge.

# REFRIGERATOR INSTALLATION

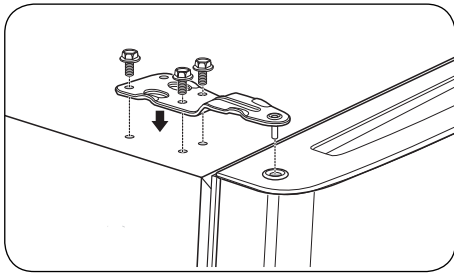

Tighten the bolts. Force-fit Top Hinge Cover over Top Hinge.

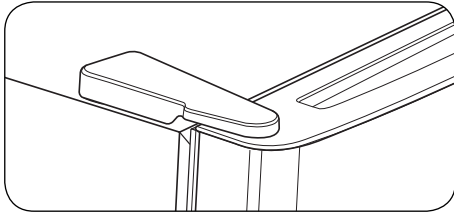

Replace cover on the top left side of the refrigerator to the right top to cover the holes. Cover is also force-fitted.

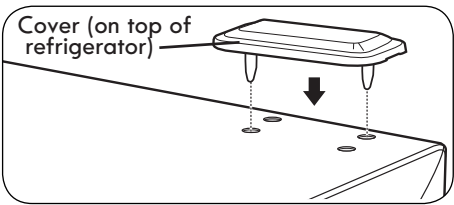

After changing doors, make sure that the corners of the Door Gaskets are not folded over. To ensure a good seal, apply a small amount of silicon grease on the corners of gaskets.

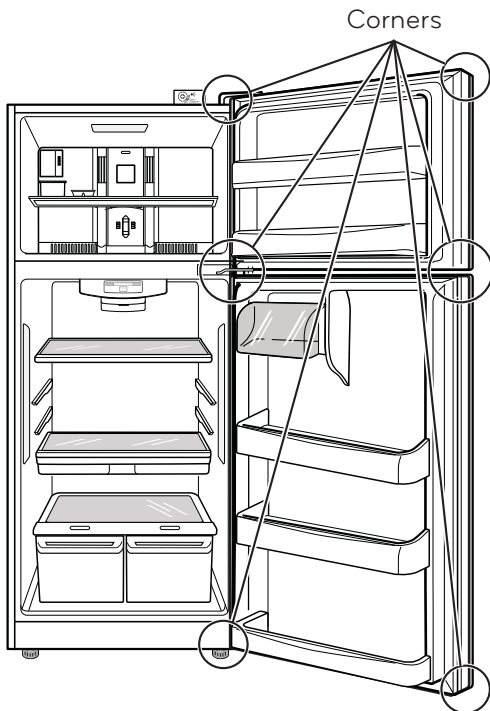

## CLOSING AND ALIGNING THE DOORS

To avoid vibration, the unit must be leveled. If necessary, adjust the Leveling Legs to compensate for unevenness of the floor. The front should be slightly higher than the rear to aid in door closing.

Your refrigerator has three front leveling screws, one on the right and one on the left. If your refrigerator seems unstable or if you would like the doors to close more easily, simply adjust the inclination of the refrigerator by following the instructions below:

**NOTE:** Third leveling screw is used for protection of hinge lower.

1. Plug the refrigerator into a 3 prong grounded outlet. Move the refrigerator into its final position.
2. Use a 11/16" (18 mm) wrench or an adjustable wrench to adjust the leveling screws (see Figure A), turning clockwise to raise the side of the refrigerator and counter-clockwise to lower it. It may take several turns to adjust it to the inclination you would like.

**NOTE:** Having someone push against the top of the refrigerator takes some weight off the leveling legs. This will make it easier to adjust the level.

3. Open both doors again and check to make sure that they close easily. If not, tilt the refrigerator slightly more to the rear by turning both Leveling Screws clockwise. It may take several more turns, and you should turn both Leveling Screws the same times.

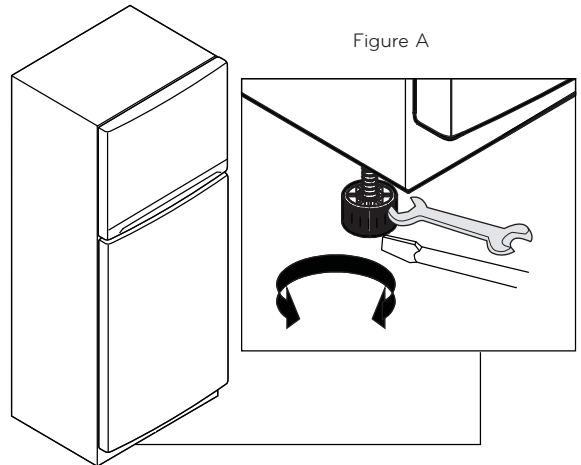

## Door Alignment

If the space between your doors is uneven, follow the instructions below to align the doors:

1. Gently pry off the Top Hinge Cover with a flat head screwdriver and remove.
2. Loosen the Top Hinge Bolts using a 10 mm or 13/32 inch socket wrench or open-end wrench.
3. Have someone hold the freezer door so the space between the two doors is even, and retighten the top hinge bolts.
4. Replace the Top Hinge Cover.

# USING YOUR REFRIGERATOR

## ENSURING PROPER AIR CIRCULATION

In order to obtain stable temperature, the air must flow between the freezer and refrigerator sections. As shown in the illustration below, the cold air enters through the bottom part and circulates upward. This air returns below the freezer floor and the rest of the air enters the refrigerator section through the top vent.

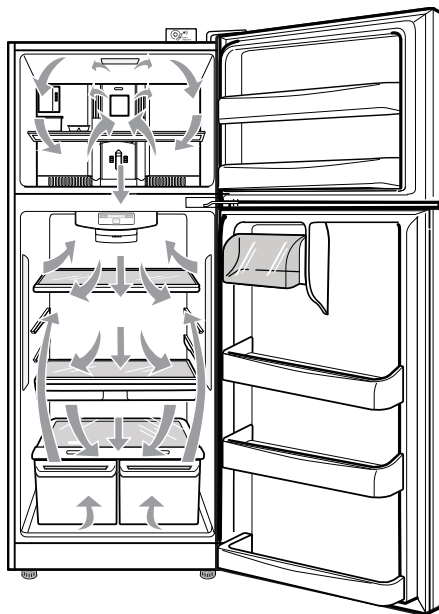

**Do not** block any of these vents with packages of food. This can interrupt the flow of air and cause temperature and moisture problems.

**IMPORTANT:** Because air circulates between both sections, any odors formed in one section will transfer to the other. You must thoroughly clean both sections to eliminate odors. To prevent odor transfer and drying out of food, make sure you wrap or cover foods tightly (See the **"Food Storage Guide"** section for details).

**NOTE:** If you close the fresh food compartment door applying more force than necessary, freezer door may get open and close again, due internal air flow of refrigerator.

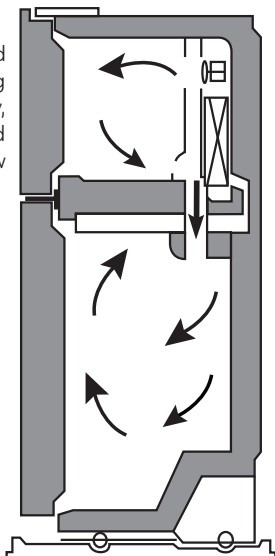

## ADJUSTING THE CONTROLS

- Your refrigerator has two controls that allow you to regulate the temperature the freezer and refrigerator compartments.

### • Refrigerator Control (On Some Models)

Initially set the Refrigerator Control on the middle setting (number 3). To do so, press the TEMPERATURE ADJUST button until it reaches the middle position (the third LED turns ON). Leave the refrigerator on this setting for 24 hours to reach the correct temperature. After 24 hours, adjust the compartment temperature as you desire. ALWAYS wait 24 hours before you adjust the temperature. If you want to set the refrigerator compartment temperature to a warmer temperature than the current, continue pressing the TEMPERATURE ADJUST button until it reaches the desired temperature.

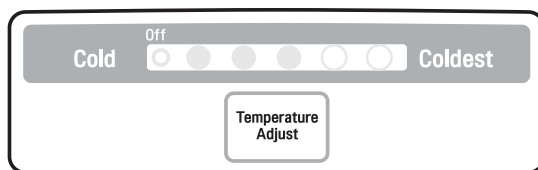

### • Demo Mode (For Store Use Only)

Demo Mode disables all cooling in the refrigerator and freezer sections to conserve energy while on display in a retail store. When activated, OFF will display on the control panel.

### To deactivate:

Press the TEMPERATURE ADJUST button until your desired temperature setting is reached. The OFF light will turn off once the Demo Mode is deactivated.

### • Freezer Control

The freezer control should come from factory on the middle setting (number 3). Wait 24 hours before adjusting the freezer compartment temperature. Roll the knob to set the freezer temperature as you desire. ALWAYS wait 24 hours after any adjustment to reach the desired temperature.

**NOTE:** Setting at higher number of the freezer compartment, the temperature of freezer compartment becomes colder.

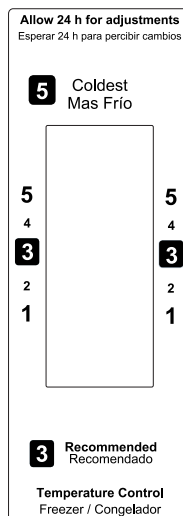

## USING YOUR REFRIGERATOR

### ADJUSTING CONTROL SETTINGS

Give the refrigerator time to cool down completely before adding food. It is best to wait 24 hours before adding food to the refrigerator. The mid-settings indicated in the previous section should be correct for normal household refrigerator usage. The controls are set correctly when milk or juice is cold to your liking and ice cream is firm.

The refrigerator control functions as the thermostat for the entire appliance. The higher the number setting, the longer the compressor will run to keep the temperature colder. The freezer control adjusts the cold air flow from the freezer to the refrigerator. Setting the freezer control to a lower temperature keeps more cold air in the freezer compartment to make it colder.

If you need to adjust the temperature in the refrigerator or freezer, begin by adjusting the refrigerator first. Wait 24 hours after the refrigerator adjustment to check the freezer temperature. If it is too warm or too cold, then adjust the freezer control as well.

Use the settings listed in the table below as a guide.

CONDITION/REASON:	RECOMMENDED ADJUSTMENT:
<b>REFRIGERATOR section is too warm</b> <ul style="list-style-type: none"> <li>Opening the door often</li> <li>Adding a large amount of food</li> <li>Room temperature is very warm</li> </ul>	<b>Adjust the REFRIGERATOR setting to the next highest number and wait 24 hours, then check.</b>
<b>FREEZER section is too warm/ ice is made too slowly</b> <ul style="list-style-type: none"> <li>Opening the door often</li> <li>Adding a large amount of food</li> <li>Room temperature is very low (not cycling often enough)</li> <li>Using ice frequently</li> <li>Air vents blocked by objects</li> </ul>	<b>Adjust the FREEZER setting to the next highest number and wait 24 hours, then check.</b>  <b>Remove any objects blocking air flow.</b>
<b>REFRIGERATOR section is too cold</b> <ul style="list-style-type: none"> <li>Controls not set correctly for your conditions</li> </ul>	<b>Adjust the REFRIGERATOR setting to the next lowest number and wait 24 hours, then check.</b>
<b>FREEZER section is too cold</b> <ul style="list-style-type: none"> <li>Controls not set correctly for your conditions</li> </ul>	<b>Adjust the FREEZER setting to the next lowest number and wait 24 hours, then check.</b>

### FOOD STORAGE GUIDE

ITEMS	HOW TO STORE
<b>Storing Fresh Food</b>	Wrap or store food in the refrigerator in airtight and moisture-proof material unless otherwise noted. This prevents food odor and taste transfer throughout the refrigerator. For dated products, check date code to ensure freshness.
<b>Butter or margarine</b>	Store opened butter in a covered dish or in a closed compartment. When storing a larger quantity, wrap in freezer packing and freeze.
<b>Cheese</b>	Store in original packaging until you are ready to use it. Once opened, tightly rewrap with plastic wrap or aluminum foil.
<b>Vegetables with skins (carrots, peppers)</b>	Place in bags or plastic containers inside the crisper.
<b>Fruit</b>	Wash and let dry; store in plastic bags in the refrigerator. Do not wash or pit berries until you are ready to eat them. Berries should be selected and kept in their original packaging (if there is any) or in a paper bag closed halfway and set on a shelf.
<b>Leafy Vegetables</b>	Remove original packaging and trim any dirty or discolored parts. Wash in cold water and drain. Place in a plastic bag or plastic container and store in the crisper.
<b>Fish</b>	Consume fish or seafood the same day purchased.
<b>Chef Fresh</b>	Store any meat in original airtight, moisture-proof packaging. Rewrap if necessary.
<b>Leftovers</b>	Cover leftovers with plastic wrap or aluminum foil. Plastic containers with airtight lids can also be used.

# USING YOUR REFRIGERATOR

## Packaging Recommendations:

- Use sealed plastic containers.
- Use plastic containers with a smooth surface.
- Package with aluminum foil of high resistance.
- Wrap with paper layered with plastic.
- Use water proof plastic.
- Use recommended plastic bags to store frozen foods.

Follow these packaging or container instructions in order to reach the best freezing

## Do not use:

- Bread Wrapping.
- Plastic container not safe for storing.
- Containers without lids or seals.
- Waxed paper or waxed plastic.
- Thin wrapping paper or not water proof.

## Freezing

**IMPORTANT:** Do not keep bottles in the freezer compartment, they may explode after freezing and cause damage.

For the maximum use of your freezer do not store excess food. Do not introduce a large amount of unfrozen foods that cannot be frozen within 24 hours (no more than 2 - 3 pounds or ,91 kg - 1,36 kg of food per square inch of space in the freezer). Sufficient space must be left in order for the air to circulate properly around the packages. Leave enough space in order to close your refrigerator with out difficulty.

Storage times can vary depending on the type and quality of the food, the way its package, or packaging container used, (in comparison to air and humidity), and the temperature it being stored in. Ice crystals formed inside your package are normal it indicates the air and humidity inside your package have condensed.

**NOTE:** Let warm foods cool off at room temperature for approximately 30 min, then wrap accordingly with the methods mention above and freeze. By letting your warm foods cool off before you introduce them to your freezer it will save you energy.

## ⚠ WARNING

### SUFFOCATING DANGER

Adequate ventilation is required when using dry ice. Dry ice is Carbon Dioxide (CO<sub>2</sub>). When it evaporates it produces oxygen, causing dizziness, slight headaches, unconsciousness or death. Do not inhale these vapors and properly ventilate the room while in use of dry ice.

## REFRIGERATOR SHELVES

The glass shelves in your refrigerator are adjustable to meet your individual storage needs.

Adjusting the shelves to fit different heights of items will make finding the exact item you want easier. Doing so will also reduce the amount of time the refrigerator door is open which will save energy.

**IMPORTANT:** Do not clean glass shelves with warm water while they are cold. Shelves may break if exposed to sudden temperature changes or impact.

**NOTE:** Glass shelves are heavy. Use special care when removing them.

### Adjusting Shelves

Remove shelves from the shipping position and replace shelves in the position you want.

To remove a shelf—Tilt up the back of the shelf in the direction of 1 and lift it in the direction of 2 . Pull the shelf out.

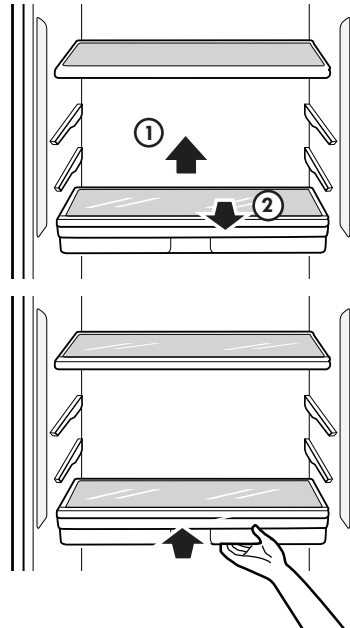

To reinstall a shelf—Slide the shelf into the guides until it stops.

## PANTRY DRAWER (on some models)

To remove the Pantry Drawer:

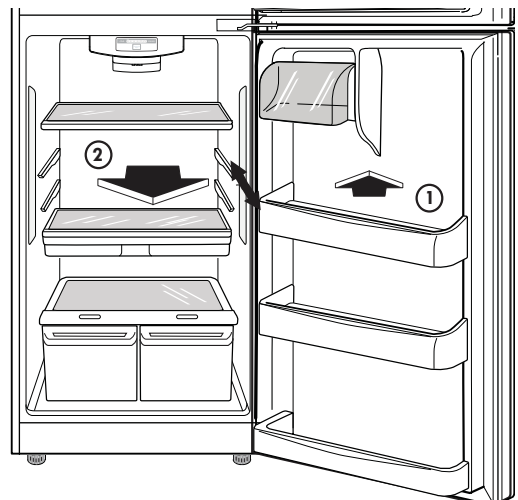

## USING YOUR REFRIGERATOR

Grasp the drawer handle and pull it forward to the drawer stop. Lift up and pull out.

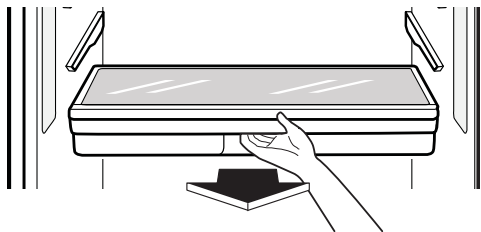

### To replace the Pantry Drawer:

Slide the drawer back all the way past the drawer stop.

### Ice Tray (On some models)

- Pour potable water to the level indicated in the picture. Do not overfill with water or ice cubes will be difficult to remove
- For quick freeze, adjust the freezer dial to 3.

### Twist the ice tray to remove the ice cubes

- Do not bend the ice tray. Doing so may result in damage to the tray.
- To remove ice cubes easily, pour water on the back of the tray or soak it in water before removing ice cubes.



### To remove the crisper glass:

1. Remove the crisper drawers (as described above).
2. Reach in under the glass and lift up.
3. Gently push the glass up and out.

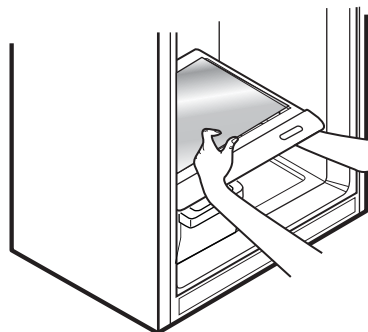

### To remove the crisper cover:

1. Remove both crisper drawers.
2. Remove the crisper glass.
3. While holding the support and crisper cover, pull up and out.

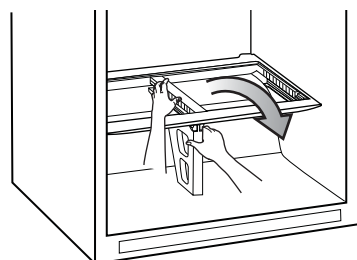

### DOOR BINS

The door bins are removable for easy cleaning and adjustment.

1. To remove the bin, simply lift the bin up and pull straight out.
2. To replace the bin, slide it in above the desired support and push down until it snaps into place.

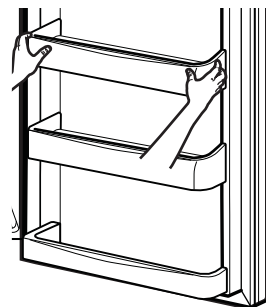

**NOTE:** Some bins may vary in appearance and will only fit in one location.

### DAIRY BIN

1. To remove the Dairy Bin, simply lift up and pull out.
2. To replace the Dairy Bin, slide it in above the desired support slots and push down until it stops.

### HUMIDITY CONTROLLED CRISPERS

The crispers provide fresher tasting fruit and vegetables by letting you easily control humidity inside the drawer.

You can control the amount of humidity in the moisturesealed crispers by adjusting the control to any setting between **VEGETABLES** and **FRUIT**.

- **VEGETABLES** keeps moist air in the crisper for best storage of fresh, leafy vegetables.
- **FRUIT** lets moist air out of the crisper for best storage of fruit.

### To remove and install the crisper drawers:

1. Pull the crisper drawer out to the drawer stop.
2. Lift the front of the crisper up, then pull it straight out.
3. To install, slightly tilt up the front, insert the drawer into the frame and push it back into place, past the drawer stop.

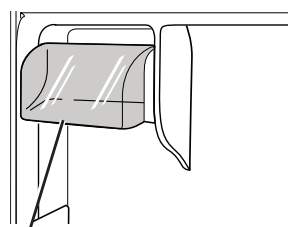
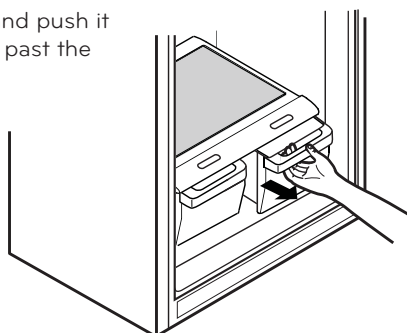

Dairy Bin

## USING YOUR REFRIGERATOR

### WATER DISPENSER (On some models)

To dispense cold water, push on the dispenser switch with a glass.

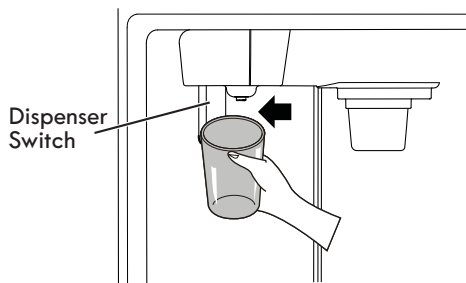

Some dripping may occur after dispensing. Hold your cup beneath the dispenser for a few seconds after dispensing to catch all of the drops.

**⚠ WARNING:** Do not put your fingers up the ice chute opening. Doing so can result in severe injury.

**⚠ CAUTION:** Do not dispense ice into fine china or crystal glasses. China or crystal can break.

### AUTOMATIC ICEMAKER (on some models)

The icemaker will produce approximately 100-130 cubes in a 24-hour period, depending on freezer compartment temperature, room temperature, number of door openings and other operating conditions.

- It takes about 12 to 24 hours for a newly installed refrigerator to begin making ice. Wait 72 hours for full ice production to occur.
- Ice making stops when the bin fills to the level of the feeler arm.
- To turn off the automatic icemaker, set the icemaker switch to **OFF (O)**. To turn on the automatic icemaker, set the switch to **ON (I)**.
- The water pressure must be between 20 and 120 psi on models without a water filter and between 40 and 120 psi on models with a water filter to produce the normal amount and size of ice cubes.

**⚠ CAUTION:**

- Throw away the first few batches of ice (about 24 cubes). This is also necessary if the refrigerator has not been used for a long time.
- Never store beverage cans or other items in the ice bin for the purpose of rapid cooling. Doing so may damage the icemaker or the containers may burst.
- Never use thin crystal glass or crockery to collect ice. Such containers may chip or break resulting in glass fragments in the ice.

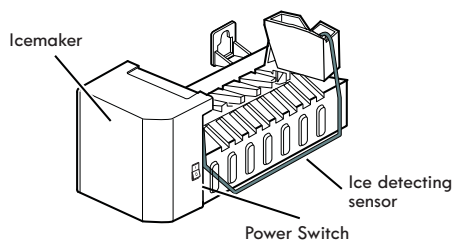

### WHEN YOU SHOULD SET THE ICEMAKER POWER SWITCH TO OFF (O)

- When the water supply will be shut off for several hours.
- When the ice bin is removed for more than one or two minutes.
- When the refrigerator will not be used for several days.

**NOTE:** The ice bin should be emptied when the icemaker ON/OFF switch is turned to the OFF position.

### NORMAL SOUNDS YOU MAY HEAR

- The icemaker water valve will buzz as the icemaker fills with water. If the power switch is in the **ON (I)** position, it will buzz even if it has not yet been hooked up to water. To stop the buzzing, move the power switch to **OFF (O)**.

**NOTE:** Keeping the power switch in the ON (I) position before the water line is connected can damage the icemaker.

- You will hear the sound of cubes dropping into the bin and water running in the pipes as the icemaker refills.

### PREPARING FOR VACATION

Set the icemaker power switch to OFF (O) and shut off the water supply to the refrigerator.

**NOTE:** The ice bin should be emptied anytime the icemaker ON/OFF switch is turned to the OFF (O) position.

If the ambient temperature will drop below freezing, have a qualified technician drain the water supply system to prevent serious property damage due to flooding caused by ruptured water lines or connections.

### ⚠ WARNING

#### Personal Injury Hazard

DO NOT place fingers or hands on the automatic ice making mechanism while the refrigerator is plugged in.

# WATER FILTER

## WATER FILTER (On some models)

It is recommended that you replace the water filter.

- Approximately every 6 months.
- When the Filter Exchange indicator turns on.
- When the water dispenser output decreases.
- When the ice cubes are smaller than normal.

## REMOVE THE OLD WATER FILTER.

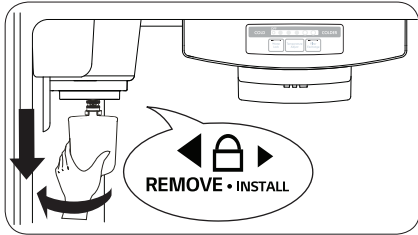

**NOTE:** Replacing the water filter causes a small amount of water (around 1 oz. or 25 cc) to drain. Wrap a cloth around the front end of the water filter cover to collect any water. Hold the water filter upright, once it is removed, to prevent any remaining water from spilling out of the water filter.

1. Make sure to turn off the household water supply.
2. Turn the filter counterclockwise and then pull down and out. Make sure to rotate the filter down completely before pulling it out of the manifold hole.

**NOTE:** The substitute cap must be retained for the future. If the filter is removed and not replaced, it is necessary to reinstall the substitute cap to prevent water leaks from the filter housing.

## REPLACE WITH A NEW WATER FILTER

1. Remove the red cap from the filter.

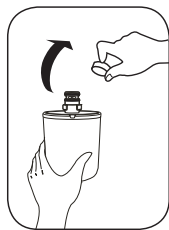

2. Insert the filter into the filter receptacle on the left side of the refrigerator compartment.

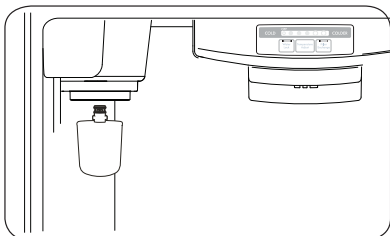

3. Push the water filter up into the filter receptacle and rotate it clockwise to lock it into place. Once installed correctly, you should not be able to rotate the filter clockwise any more.

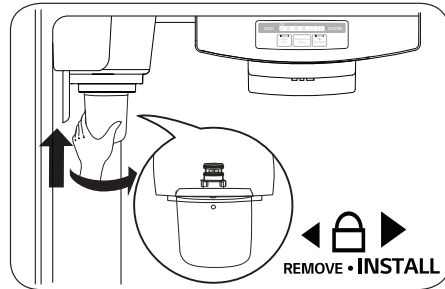

## AFTER INSTALLING THE WATER FILTER:

1. Replace the shelf to the initial position.
2. Turn on household water supply.
3. Dispense 2.5 gallons (9.46 liters) of water to purge the system, depressing and releasing the dispenser pad in cycles of 30 seconds ON and 60 seconds OFF. Open the refrigerator door and check the shelf area for water leaks.

**Replacement Filter: ADQ72910906.**

## REFRIGERATOR CARE AND CLEANING

### **⚠ WARNING**

#### **EXPLOSION HAZARD**



Do not use flammable cleaners. Not following these instructions can cause death, explosion or fire.

The refrigerator, as well as the freezer, do their own de-freezing. This process does not prevent the build up of contaminants, therefore it is suggested that you clean both parts once a month; clean spilled liquids immediately.

#### **REFRIGERATOR CLEANING**

- Unplug your refrigerator.
- Pull out all of the removable parts (such as the vegetable and dairy doors).
- Use a clean sponge (or a soft rag) and use it with lukewarm water mixed with detergent. Do not use abrasive or concentrated cleaners.
- Hand wash it, and dry it thoroughly.
- Plug the refrigerator back in.

#### **OUTSIDE**

Wax the outside in order to create better protection. Make sure you use a product specifically design to be used for electro-domestic products (car wax is acceptable). Use a clean, soft rag, and perform this task twice a year. For metal-made refrigerators, do not wax, simply clean it with water and detergent. Do not use concentrated or abrasive products.

In case of STS, apply cleaner in same direction that hair line of STS.

**NOTE:** Avoid the usage of chemical products that contain phosphates or bleach.

#### **INSIDE (Allow freezer to slightly warm up a small degree to prevent cloth from sticking)**

In order to eliminate bad odors, clean the inside of the refrigerator with a mixture of baking powder and lukewarm water (one teaspoon of baking powder per cup of water). Ensure that the powder dissolves thoroughly, in order to prevent any sort of damage.

#### **DOOR LINING AND GASKETS**

Use only a mild detergent (such as dish soap).

#### **PLASTIC PARTS (Covers and Panels)**

Do not use abrasive, paper or rough products. These could damage the product.

#### **BACK COVER**

### **⚠ WARNING**

#### **ELECTRICAL SHOCK HAZARD**

Before you begin, either unplug the refrigerator or turn off power at the circuit breaker or fuse box.

**NOTE:** Back Cover should only be removed by a qualified technician.

In order to get an efficient performance of your refrigerator, clean the back cover of it at least twice a year.

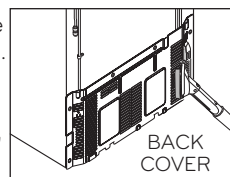

#### **REPLACING REFRIGERATOR LIGHTS**

The refrigerator and freezer compartment lights are LED interior lighting, and service should be performed by a qualified technician.

### **⚠ WARNING**

#### **ELECTRIC SHOCK HAZARD**

Before replacing a burned-out light bulb, either unplug the refrigerator or turn off power at the circuit breaker or fuse box.

#### **POWER INTERRUPTIONS**

1. In case of a black out, call your electric company and ask how long it will last.
2. In case of a 24 hour or less black out, do not open the refrigerator; this will keep the food fresh.
3. In case of a longer black out, do one of the following options:
  - Pull out all of the frozen food and keep them in an ice chest.
  - Put 2 lbs (907 g) of frozen ice (make sure you use gloves) for each square foot (28 L) inside the freezer. This task will preserve the food from 2 to 4 days.
  - In case you do not possess neither ice chest or dry ice, consume your food as soon as possible.

**REMEMBER:** In a power failure, a full freezer stays cold longer than a partially filled one. A freezer full of meat stays cold longer than a freezer full of baked goods. If you see that food contains ice crystals, it may be safely refrozen, although the quality and flavor may be affected. If the condition of the food is poor or if you feel it unsafe, dispose of it.

#### **WHEN GOING ON VACATION**

If you decide to leave your refrigerator on when going away, consider these steps:

1. Consume all of the perishable items and freeze the rest.
2. Empty the ice bin.

If you decide to leave your refrigerator off:

1. Remove all of the food.
2. Unplug your refrigerator.
3. Clean and dry it well.
4. Make sure the doors stay open (use blocks or tape) in order to prevent bad odors and fungi from happening.

## REFRIGERATOR CARE AND CLEANING

### WHEN MOVING

If you decide to take your refrigerator with you when moving, consider the following:

1. Remove all of the food from it, and place the frozen food in an ice chest with dry ice.
2. Unplug your refrigerator.
3. Empty the water from its tray.
4. Clean and dry it with a rag.
5. Pull out all of the removable parts, and wrap them with adhesive tape.
6. Depending on the model of the refrigerator, lift the top part of the refrigerator so it can roll with ease, or screw the levelers so it won't scratch the floor. Consult to the section **"Closing and Aligning Doors"**.

7. Keep the doors closed with the cable glued to the refrigerator cabinet with an adhesive tape.

When your refrigerator arrives to your home, put everything back into place and read the section **"Refrigerator Installation"** in order to obtain installation preparation. In case your refrigerator has a factory ice maker, remember you have to reconnect the water supply.

## ABOUT THE AUTOMATIC ICE MAKER

**NOTE:** The automatic Ice maker is only included in some models. Check your specifications of your refrigerator.

### ⚠ WARNING

#### PERSONAL INJURY HAZARD

Avoid contact with any moving parts of the ejector mechanism or with the heater that releases the ice cubes. **DO NOT** place your fingers in the automatic ice maker when the refrigerator is plugged in.

### OPERATING INSTRUCTIONS

After turning on your refrigerator, the ice will start to be made between 12 and 24 hours.

**Identify your ice maker type.**

#### Type 1

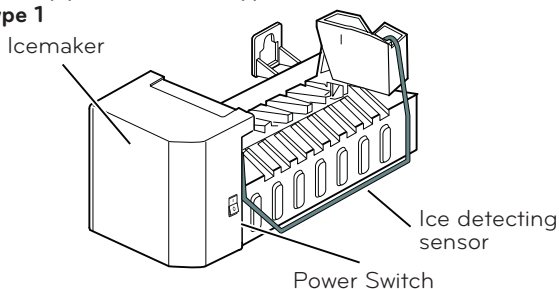

The ice maker produces 8 cubes per cycle (between 64 and 128 cubes in a 24 hour period), depending on the temperature of the freezer, the times in which the door opens, and other using conditions (amount of food in the freezer, etc).

If the refrigerator is used before the connection of water to the ice maker was performed, you must turn its dial to **O** (off).

When the water connections are performed, turn its dial to **I** (on).

The ice maker will fill up (and start making ice) between 12 and 24 hours after the refrigerator is turned on.

Throw away the first batch of ice. Make sure that nothing interferes with the sensor.

When the ice reaches the sensor, the ice maker will stop to make ice immediately.

It's normal that some ice gets stuck. If the ice is not used frequently, the older cubes of ice will be opaque in color, smaller, and with a strange flavor.

**NOTE:** Never store beverage cans or other items in the ice bin for the purpose of rapid cooling. Doing so may damage the ice maker or the container may burst.

#### YOU MUST TURN THE SWITCH TO **O** (OFF)

- When the water supply is interrupted for many hours.
- When the ice container is left out of its place for more than one or two minutes.
- When the refrigerator will not be in use for various days.

#### NORMAL SOUNDS

- The valve will emit a buzzing sound when the ice maker is full of water. If the switch is placed in the on position the buzz will still be heard even when the water pipe has not been connected. To avoid this sound, move switch to **O** (off) position.

**NOTE:** The ice maker can get damaged if the switch is kept in the ON position before the water pipe has been connected.

- While the ice maker is filling up with water and producing ice, you will hear the sound of the ice falling and water flowing through the pipes.
- You will hear the sound of cubes dropping into the bin and water running in the pipes as the icemaker refills.

#### PREPARING FOR VACATIONS

Move the ice maker switch to the **O** (off) position and cut the flow of water going into the refrigerator.

If room temperature is at freezing point, have a specialized technician drain the flow of water from the inner pipes (certain models) to avoid broken pipe related damage.

**NOTE:** To avoid water spilling, the unit should be leveled and placed on even floor. Do not remove the ice bin from the ice maker for a long period, doing so may cause ice spilling.

## CONNECTING THE WATER LINE

**NOTE:** It is necessary to have a water source when both water and/or ice dispensers are available in your product. Check the specifications and model of your refrigerator.

### BEFORE START

The water source is not guaranteed by the refrigerator manufacturer. Follow instructions carefully in order to reduce damage.

Air located inside the water pipes can cause hammering or tapping causing damage to the inner pipes or water spillage in the inside of the refrigerator. Call a qualified plumber to fix such hammering on the connections before installing the water pipe.

To avoid burn damage or such, never connect refrigerator to hot water pipes.

If you are to use the refrigerator before connecting it to the water source, make sure the ice maker is the off position.

Never attempt to install the ice maker pipes in areas where room temperature is below freezing point.

When using any electrical device (like a drill) during the installation, make sure device is doubly isolated or making ground to prevent risk of electrical surge or discharge.

All installations should be done considering local water and drainage requirements.

- If an inverted osmosis water filtration system is connected to the cold water source, the water hose installation is not assured or guaranteed by the refrigerator or automated ice maker manufacturer. Follow the next instructions carefully to minimize costly water related damages.
- When having an inverted osmosis water filtration system connected to the cold-water flow, the water pressure for such system must be at least between 40-60 PSI or 0,27 MPa ( $2,8 \text{ kg} \cdot \text{f} / \text{cm}^2 \sim 4,2 \text{ kg} \cdot \text{f} / \text{cm}^2$ , ( $2,8 \text{ kg} \cdot \text{f} / \text{cm}^2 \sim 4,2 \text{ kg} \cdot \text{f} / \text{cm}^2$ , less than  $2 \sim 3$  seconds to fill a 7 oz of capacity cup [0,2 liters])).
- If the inverted osmosis water filtration system pressure is less than 21 PSI or 0,14 MPa ( $1,5 \text{ kg} \cdot \text{f} / \text{cm}^2$ , more than four (4) seconds to fill a 7 oz of capacity cup [0,2 liters]):
  - a) Identify if the sediments filter in the inverted osmosis system is being blocked. Replace filter if necessary.
  - b) Allow inverted osmosis system storage tank to refill after extensive usage.
  - c) Call a qualified plumber if the inverted osmosis water pressure problem continues.

### REQUIREMENTS

- **1/4" (6,35 mm) in diameter copper pipe** to connect refrigerator to the water pipe. Make sure both terminals are cut in a squared manner.



To determine how much pipe material is needed, measures the distances between the valves located

behind the refrigerator and the source of water and add to that 8 feet (2,4 m). Make sure there is sufficient pipe material to allow the free movement of the refrigerator from the wall

- **A cold water source.** Water pressure should be between 0,138 and 0,82 MPa or 20 and 120 PSI for models not containing water filter and between 0,276 and 0,82 MPa or 40 and 120 PSI for models containing water filter.

- **A drill.**

- **Adjustable 1/2" (12,7 mm) key.**

- **Flat and Phillips style (star) screwdriver.**

- **Two 1/4" (6,35 mm) diameter compression nuts** with two sides to connect the copper pipe to the refrigerator valve.

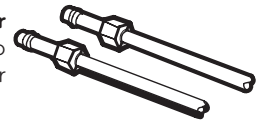
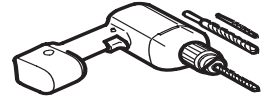

If your current copper pipe has some reduction on the ends, it will be necessary to get an adaptor (found in hardware stores) to connect the water line to the refrigerator. It is also possible to cut such reductions with a pipe cutter and use the compression connections mentioned above.

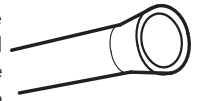

- **Bypass valve** to connect to the cold water line. The valve must have a water opening with an interior 5/32" (3,46 mm) diameter in the cold-water connection point. These valves can be located in any cold-water connection package. Before buying make sure such valve meets local standards and requirements.

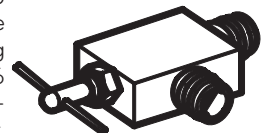

### INSTALLATION INSTRUCTIONS

Install the valve to the pipe that you use to drink water.

**⚠ CAUTION:** Connect to potable water supply only.

#### 1. CLOSE THE MAIN WATER SOURCE

Open the nearest water faucet to let water flow and empty pipes.

#### 2. SELECT THE LOCATION OF THE VALVE

Select the location of the valve that will provide a better access. It is best to connect to a vertical pipeline. When connecting to a horizontal pipeline is necessary, make the connection in the lateral or upper area instead of the lower area to prevent accumulation of sediment.

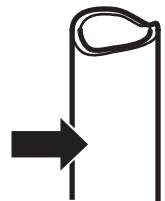

## CONNECTING THE WATER LINE

### 3. DRILL A HOLE FOR THE VALVE

Drill a 1/4" (6,35 mm) diameter hole in the water pipeline. Remove jagged edges produced after perforation. Make sure water does not reach the drill. Not performing the 1/4" (6,35 mm) perforation can lead to a low or smaller ice production.

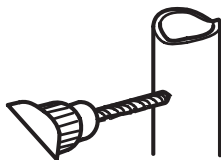

### 4. TIGHTEN THE VALVE

Tighten the valve into the cold water pipeline with a tube trap.

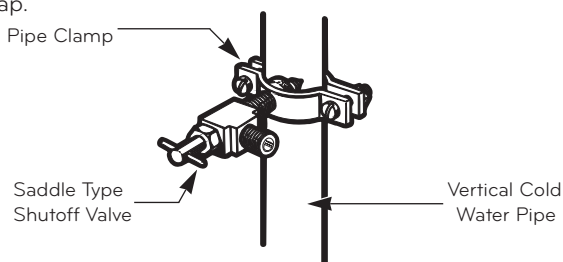

**NOTE:** Codes for 248 CMR pipelines of the state of Massachusetts must be attached to the connection. Valves of this type are banned in Massachusetts. Call an authorized plumber by the norms and regulations of your country.

### 5. TIGHTEN THE TRAP

Tighten the trap until the sealing ring begins to grow.

**NOTE:** Make sure it is not too tight, this can break the pipe.

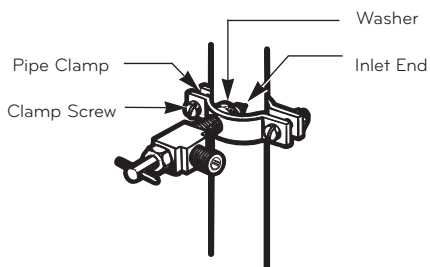

### 6. PLACE THE PIPELINE

Place the pipeline between the cold water pipe and the refrigerator. Place it through a hole in the wall or floor (behind the refrigerator or next to the cabinet) as close to the wall as possible.

**NOTE:** Make sure there is a sufficient amount of extra pipeline (8 feet [244 mm] coiled up three times with a 10" [25 cm] in diameter) to allow free movement of the refrigerator from the wall after installation was made.

### 7. CONNECT PIPELINE TO VALVE

Place the compression nut and the copper pipe ferule at the end of the pipe and connect to the valve. Make sure the pipe is completely inserted into the valve. Tighten nut carefully.

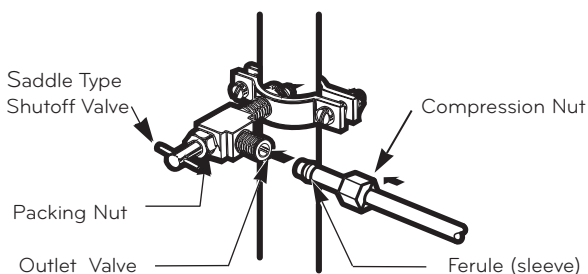

### 8. DRAIN THE PIPE

Open the main water source (1) and drain the pipe until water comes out clear.



Allow water flow from the bypass valve (2) and close after draining 1/4 of a gallon (1L) of water.

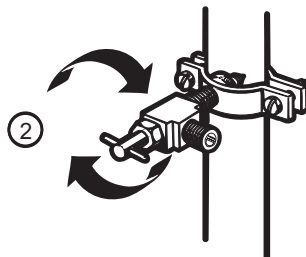

### 9. CONNECT PIPE TO REFRIGERATOR

#### NOTES:

- Before making connection to refrigerator, make sure it is not connected to any energy source. If your refrigerator does not have a water filter, it is advised to install one.
- If your water source contains sand or related particles that can travel to the valve, install a water filter near the refrigerator.

**IMPORTANT:** Never use old or used hoses. Always use new ones to have a better use and experience. Connect always to a potable water source to avoid security and health issues.

- Remove the ring plug (1) from the valve located at the top of such device.

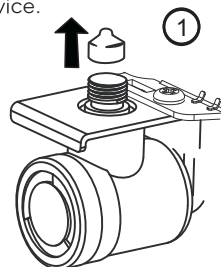

## CONNECTING THE WATER LINE

- Place compression nut and the ferrule at the end of the pipeline. Insert pipeline into the connection valve as far as possible. Hold tightly while holding pipeline.

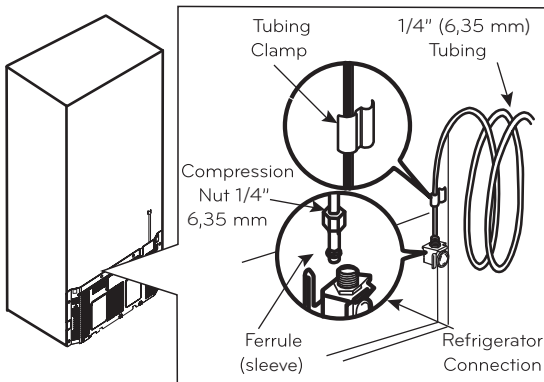

Hold on to the pipe from the handles or grabbers located behind the refrigerator, loosening first the bolt holding the handle. Afterwards, insert pipe into the hole and tighten bolt to finalize.

### 10. OPEN THE BYPASS VALVE

Tighten all connections containing leaks. Place access cover back on compressor.

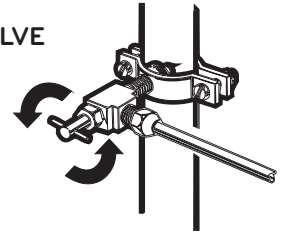

### 11. CONNECT TO REFRIGERATOR

Fix pipeline in a way that it does not vibrate on the refrigerator or wall. Push refrigerator against wall.

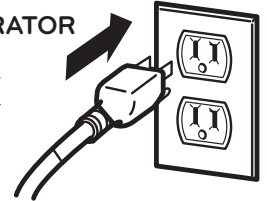

### 12. TURN ICE MAKER ON

Turn ice maker switch into the **ON** position. Ice maker will start only after reaching its operating temperature of 15 °F (-9 °C) or less. It will automatically begin the ice production if switch is located in the **ON** position.

## TROUBLESHOOTING GUIDE

### UNDERSTANDING SOUNDS YOU MAY HEAR

Your new refrigerator may make sounds that your old one did not make. Most of the new sounds are normal. Hard surfaces, like the floor, walls and cabinets, can make the sounds seem louder than they actually are. The following describes the kinds of sounds you may hear and what may be causing them..

#### Clicking:

The defrost control will click when the automatic defrost cycle begins and ends. The thermostat control (or refrigerator control, depending on the model) will also click when cycling on and off.

#### Rattling:

Rattling noises may come from the flow of refrigerant, the water line, or items stored on top of the refrigerator.

#### Whooshing:

- Evaporator fan motor circulating the air through the refrigerator and freezer compartments.
- Air being forced over the condenser by the condenser fan.
- Ice compartment fan in the freezer on the left side of the refrigerator when the doors are open.

#### Gurgling:

As each cycle ends, you may hear a gurgling sound caused by the refrigerant flowing through the cooling system.

#### Popping:

Contraction and expansion of the inside walls.

#### Sizzling:

Water dripping on the defrost heater during a defrost cycle.

#### Vibrating Noise:

If the side or back of the refrigerator is touching a cabinet or wall, some of the normal vibrations may make an audible sound. To eliminate the noise, make sure that the sides and back cannot vibrate against any wall or cabinet.



#### Dripping:

Water running into the drain pan during the defrost cycle.

#### Pulsating or High-Pitched Sound:

Your refrigerator is designed to run more efficiently to keep your food items at the desired temperature. The high efficiency compressor may cause your new refrigerator to run longer than your old one, but is still more energy efficient than previous models. While the refrigerator is running, it is normal to hear a pulsating or high-pitched sound.

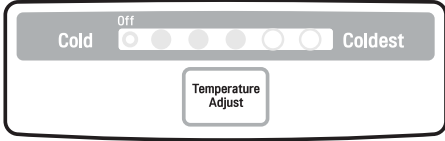
## TROUBLESHOOTING GUIDE

Problem	Possible Causes	Solutions
<b>Refrigerator is not cooling.</b>	The power supply cord is unplugged.	Firmly plug the cord into a live outlet with proper voltage (see Electrical & Grounding Requirements).
	A household fuse has blown or a circuit breaker has tripped.	Replace the fuse or reset the circuit breaker. If the problem persists, contact an electrician.
	The refrigerator control is set to the OFF position.	Refer to the Setting the Controls section.
	The refrigerator is in the defrost cycle.	Wait about 30 minutes for defrost cycle to end.
	The OFF light is illuminated. 	The refrigerator is in DEMO mode. The Demo Mode disables the cooling system and only the lamps and display will work normally. To disable Demo Mode, press the Temperature Adjust  button until you set the desired temperature level. When demo mode is deactivated, the OFF light  will turn off.
<b>Lights do not work</b>	The power supply cord is unplugged.	Firmly plug the cord into a live outlet with proper voltage (refer to Electrical & Grounding Requirements).
	An LED light has malfunctioned.	Before proceeding to replace LED, unplug the refrigerator or turn off power at the circuit breaker or fuse box. <b>NOTE:</b> The refrigerator and freezer compartment lamps are LED interior lighting, and service should only be performed by a qualified technician.
<b>Vibration or rattling noise.</b>	The refrigerator is not resting solidly on the floor.	Floor is weak or uneven or leveling legs need adjusting. See the Installation section for leveling instructions.
<b>Compressor seems to run too much.</b>	The refrigerator that was replaced was an older model.	Modern refrigerators require more operating time but use less energy due to more efficient technology.
	The room temperature is warmer than normal.	The compressor will run longer under warm conditions. At normal room temperatures (70°F) expect your compressor to run about 40% to 80% of the time. Under warmer conditions, expect it to run even more often. The refrigerator should not be operated in surrounding temperatures above 110°F.
	The door is opened often or a large amount of food has just been added.	Adding food and opening the door warms the refrigerator, requiring the compressor to run longer in order to cool the refrigerator back down. In order to conserve energy, try to get everything you need out of the refrigerator at once, keep food organized so it is easy to find, and close the door as soon as the food is removed. (Refer to the Food Storage Guide.)
	The refrigerator was recently plugged in and the refrigerator control was set correctly.	The refrigerator will take up to 24 hours to cool completely
	The refrigerator control is not set correctly for the surrounding conditions.	See the Adjusting Control Settings section.
	The doors are not closed completely.	Firmly push the doors shut. If they will not shut all the way, see "Doors will not close completely" in the Troubleshooting section.
	The back cover is dirty.	This prevents air transfer and makes the motor work harder. Clean the back cover. Refer to the Care and Cleaning section.

## TROUBLESHOOTING GUIDE

Problem	Possible Causes	Solutions
<b>Doors will not close completely.</b>	The refrigerator is not level.	See the Leveling and Door Alignment section.
	Food packages are blocking the door open.	Rearrange food containers to clear door and door shelves.
	The ice bin, crisper cover, pans, shelves, door bins or baskets are out of position.	Push bins all the way in and put crisper cover, pans, shelves and baskets into their correct positions. See the Using Your Refrigerator section for more information.
	The gaskets are sticking.	Clean gaskets and the surfaces that they touch. Rub a thin coat of appliance polish or kitchen wax on the gaskets after cleaning.
	The refrigerator wobbles or seems unstable.	Level the refrigerator. Refer to the Leveling and Door Alignment for more information.
	The doors were removed during product installation and not properly replaced.	Remove and replace the doors according to the Removing and Replacing Refrigerator Handles and Doors section, or call a qualified technician.
<b>Frost or ice crystals on frozen food.</b>	The door is not closing properly.	See "Doors will not close completely" in the Troubleshooting section.
	The door is opened often.	When the door is opened, warm, humid air is allowed in the freezer, resulting in frost.
<b>Ice has bad taste or odor.</b>	The icemaker was recently installed.	Discard the first few batches of ice to avoid discolored or bad tasting ice.
	The ice has been stored for too long.	Throw away old ice and make a new supply.
	The food has not been wrapped tightly in either compartment.	Rewrap foods since odors may migrate to the ice if food is not wrapped properly.
	The water supply contains minerals such as sulfur.	A water filter may need to be installed to eliminate taste and odor problems.
	The interior of the refrigerator needs cleaning.	See Care and Cleaning section for more information.
The ice storage bin needs cleaning.	Empty and wash bin. Discard old cubes.	
<b>There is water in the defrost drain pan.</b>	The refrigerator is defrosting.	The water will evaporate. It is normal for water to drip into the defrost pan.
	It is more humid than normal.	Expect that the water in the defrost pan will take longer to evaporate. This is normal when it is hot or humid.

## TROUBLESHOOTING GUIDE

Problem	Possible Causes	Solutions
<b>The refrigerator seems to make too much noise.</b>	The sounds may be normal for your refrigerator.	Refer to the Understanding Sounds You May Hear section for more information.
<b>The icemaker is not producing ice or not enough ice.</b>	New installation.	Wait 12 to 24 hours after icemaker installation for ice production to begin. Wait 72 hours for full ice production.
	The refrigerator is not connected to a water supply or the supply shutoff valve is not turned on.	Connect refrigerator to the water supply and turn water shutoff valve fully open.
	Reverse osmosis water filtration system is connected to your cold water supply.	Reverse osmosis filtration systems can reduce the water pressure below the minimum amount and result in icemaker issues. (Refer to Water Pressure section.)
	Kink in the water source line.	A kink in the line can reduce water flow. Straighten the water source line.
	Ice demand has exceeded storage capacity.	The icemaker will produce approximately 95 cubes in a 24 hour period. NOTE: An extra ice bucket is provided in the freezer section for additional storage capacity.
	The icemaker is not turned on.	Locate the icemaker ON/OFF switch and confirm it is in the ON (I) position.
	There is something on the ice-detecting sensor.	Foreign substances or frost on the icedetecting sensor can interrupt ice production. Make sure the sensor area is clean at all times for proper operation.
	The temperature setting for the freezer is too warm.	The recommended temperature for the freezer compartment for normal ice production is 0°F. If the freezer temperature is warmer, ice production will be affected.
	The doors are opened often.	If the doors of the unit are opened often, ambient air will warm the refrigerator which will prevent the unit from maintaining the set temperature. Lowering the refrigerator temperature can help, as well as not opening the doors as frequently.
The doors are not closing properly.	If the doors are not properly closed, ice production will be affected. See "Doors will not close completely" in the Troubleshooting section for more information.	
<b>Refrigerator or Freezer section is too cold.</b>	Controls are not set correctly for conditions.	If the temperature is too cold, raise the temperature setting one increment at a time (refer to the Setting the Controls section). When changing control settings, wait 24 hours before making additional adjustments.

## TROUBLESHOOTING GUIDE

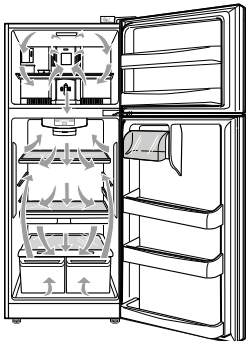
Problem	Possible Causes	Solutions
<b>Temperature is too warm or there is interior moisture buildup.</b>	The air vents are blocked. Cold air circulates from the freezer to the fresh food section and back again through air vents in the wall dividing the two sections.	Locate air vents by using your hand to sense airflow and move all packages that block vents and restrict airflow. (See air flow diagram below.)
		
	The doors are opened often.	Opening the door warms the refrigerator, requiring the compressor to run longer in order to cool the refrigerator back down. In order to conserve energy, try to get everything you need out of the refrigerator at once, keep food organized so it is easy to find, and close the door as soon as the food is removed.
	The control is not set correctly for the surrounding conditions.	If the temperature is too warm, change the setting one increment at a time. Refer to the Setting the Controls section. Wait 24 hours for temperatures to stabilize or even out.
	A large amount of food has just been added to the refrigerator or freezer.	Adding food warms the refrigerator. It can take a few hours for the refrigerator to return to normal temperature.
	The food is not packaged correctly.	Wrap food tightly and wipe off damp containers prior to storing in the refrigerator to avoid moisture accumulation. If necessary, repack food according to the guidelines in the Food Storage Guide section.
	The doors are not closing completely.	See "Doors will not close completely" in the Troubleshooting section.
	The weather is humid.	In humid weather, air carries moisture into the refrigerator when the doors are opened. Increased humidity in the freezer or refrigerator compartments can lead to frost or condensation.
<b>The doors are difficult to open.</b>	An automatic defrost cycle was completed.	It is normal for droplets to form on the interior back wall after the refrigerator automatically defrosts.
	The gaskets are dirty or sticky.	Clean the gaskets and the surfaces that they touch. Rub a thin coat of appliance polish or kitchen wax on the gaskets after cleaning.
<b>Frozen food in refrigerator compartment.</b>	The door is reopened within a short time after having been opened.	When you open the door, warmer air enters the refrigerator. As the warm air cools, it can create a vacuum. If the door is hard to open, wait one minute to allow the air pressure to equalize, then see if it opens more easily.
	The temperature control in the refrigerator compartment is set too cold.	Press the Temperature Adjust button to set the refrigerator compartment to a warmer temperature.
	Refrigerator is installed in a cold location.	When room temperature is below 41°F (5°C), food can freeze. The refrigerator should not be operated in temperatures below 55°F (13°C).
	Food with a high water content was placed too close to the cold air discharge vent.	Place food with a high water content toward the front of the refrigerator.

# SMART DIAGNOSIS™

## Smart Diagnosis™ (on some models)



Should you experience any problems with your refrigerator, it has the capability of transmitting data via your telephone to the Smart Diagnosis™ team. This gives you the capability of speaking directly to our trained specialists. The specialist records the data transmitted from the machine and uses it to analyze the issue, providing a fast, effective diagnosis.

If you experience problems with your refrigerator, call to the LG service center. Only use the Smart Diagnosis™ feature when instructed to do so by the agent. The transmission sounds that you will hear are normal and sound similar to a fax machine.

Smart Diagnosis™ cannot be activated unless the refrigerator is connected to power. If the refrigerator is unable to turn on, then troubleshooting must be done without using Smart Diagnosis™.

## Using Smart Diagnosis™

1. Open the refrigerator door.
2. Press and hold the Temperature Adjust button until you hear 4 beeps.
3. Once you hear four beeps, open the freezer door and place the mouthpiece of your phone near the Smart Diagnosis™ speaker located on the right hinge of the door.
4. Keep the phone in place until the tone transmission has finished.

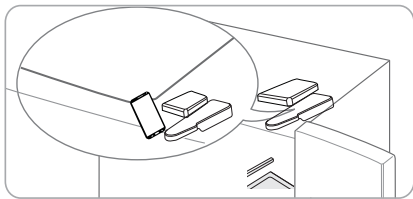

5. Once the tones have stopped, the refrigerator will be turned off briefly and then turned back on automatically. Resume your conversation with the specialist, who will be able to assist you in using the information transmitted for analysis.

### NOTE:

- For best results, do not move the phone while the tones are being transmitted.
- If the call center agent is not able to get an accurate recording of the data, you may be asked to try again.

# DOOR ALARM

## Door Alarm (on some models)

The Door Alarm function is designed to prevent refrigerator malfunctions that could occur if the refrigerator door remains open. If the refrigerator door remains open for longer than 1 minute, an alarm sounds at 30-second intervals. The alarm will stop when both refrigerator doors are closed properly.

**NOTE:** This function cannot be deactivated.

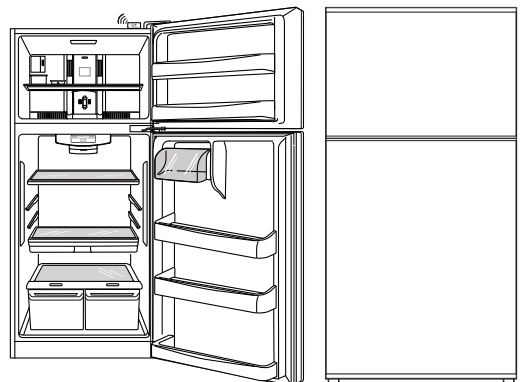

# LIMITED WARRANTY

## LG ELECTRONICS U.S.A., INC. LG REFRIGERATOR LIMITED WARRANTY - U.S.A.

**ARBITRATION NOTICE: THIS LIMITED WARRANTY CONTAINS AN ARBITRATION PROVISION THAT REQUIRES YOU AND LG TO RESOLVE DISPUTES BY BINDING ARBITRATION INSTEAD OF IN COURT, UNLESS YOU CHOOSE TO OPT OUT. IN ARBITRATION, CLASS ACTIONS AND JURY TRIALS ARE NOT PERMITTED. PLEASE SEE THE SECTION TITLED "PROCEDURE FOR RESOLVING DISPUTES" BELOW. Should your LG Refrigerator ("Product") fail due to a defect in materials or workmanship under normal and proper use, during the warranty period set forth below, LG Electronics ("LG") will, at its option, repair or replace the Product. This limited warranty is valid only to the original retail purchaser of the Product and applies only when purchased and used within the United States including U.S. Territories.**

WARRANTY PERIOD			
Refrigerator/Freezer	Sealed System (Condenser, Dryer, Connecting Tube and Evaporator)	Compressor	
One (1) year from the date of original retail purchase	Five (5) years from the date of original retail purchase	Five (5) years from the date of original retail purchase	Linear / Inverter Compressor Only : Parts Only for years 6-10 from the date of original retail purchase (Consumer will be charged for labor)
Parts and Labor (internal/ functional parts only)	Parts and Labor	Parts and Labor	

- Replacement products and parts are warranted for the remaining portion of the original warranty period or ninety (90) days, whichever is greater.
- Replacement products and parts may be new, reconditioned, refurbished, or otherwise factory remanufactured.
- Proof of original retail purchase specifying the Product model and date of purchase is required to obtain warranty service under this limited warranty.

**EXCEPT TO THE EXTENT PROHIBITED BY APPLICABLE LAW, ANY IMPLIED WARRANTY OF MERCHANTABILITY OR FITNESS FOR A PARTICULAR PURPOSE ON THE PRODUCT IS LIMITED IN DURATION TO THE DURATION OF THE ABOVE LIMITED WARRANTY. UNDER NO CIRCUMSTANCES SHALL LG OR ITS U.S. DISTRIBUTORS/DEALERS BE LIABLE FOR ANY INDIRECT, INCIDENTAL, CONSEQUENTIAL, SPECIAL, OR PUNITIVE DAMAGES, INCLUDING, WITHOUT LIMITATION, LOST GOODWILL, LOST REVENUES OR PROFITS, WORK STOPPAGE, IMPAIRMENT OF OTHER GOODS, COST OF REMOVAL AND REINSTALLATION OF THE PRODUCT, LOSS OF USE, OR ANY OTHER DAMAGES WHETHER BASED IN CONTRACT, TORT, OR OTHERWISE. LG'S TOTAL LIABILITY, IF ANY, SHALL NOT EXCEED THE PURCHASE PRICE PAID BY YOU FOR THE PRODUCT.**

Some states do not allow the exclusion or limitation of incidental or consequential damages or limitations on how long an implied warranty lasts, so the above exclusions or limitations may not apply to you. This limited warranty gives you specific legal rights and you may also have other rights that vary from state to state.

### **THIS LIMITED WARRANTY DOES NOT COVER:**

- Service trips to deliver, pick up, or install, educate how to operate, correct wiring, or correct unauthorized repairs.
- Damage or failure of the Product to perform during power failures and interrupted or inadequate electrical service.
- Damage or failure caused by leaky or broken water pipes, frozen water pipes, restricted drain lines, inadequate or interrupted water supply or inadequate supply of air.
- Damage resulting from operating the product in a corrosive atmosphere or contrary to the product owner's manual.
- Damage or failure to the Product caused by accidents, pests and vermin, lightning, wind, fire, floods, acts of God, or any other causes beyond the control of LG.
- Damage or failure caused by unauthorized modification or alteration, or if used for other than the intended purpose.
- Damage or failure resulting from misuse, abuse, improper installation, repair, or maintenance. Improper repair includes use of parts not authorized by LG. Improper installation or maintenance includes installation or maintenance contrary to the Product owner's manual.
- Damage or failure caused by incorrect electrical current, voltage, or plumbing codes.
- Damage or failure caused by transportation and handling, including scratches, dents, chips, and/or other damage to the finish of the Product, unless such damage is reported within one (1) week of delivery.
- Damage or missing items to any display, open box, or discounted Product.
- Refurbished Product or any Product sold "As Is", "Where Is", "With all Faults", or similar disclaimer.
- Products with original serial numbers that have been removed, altered, or cannot be readily determined.
- Increases in utility costs and additional utility expenses.
- Any noises associated with normal operation.
- Use of accessories (e.g., water filters, etc.), components, or consumable cleaning products that are not authorized by LG.
- Replacement of light bulbs, filters, or any consumable parts.
- When Product is used for other than normal and proper household use (e.g. commercial or industrial use, offices, and recreational facilities or vehicles) or contrary to the instructions outlined in the Product's owner's manual.
- Costs associated with removal and reinstallation of your Product for repairs.
- Shelves, door bins, drawers, handle and accessories, except for internal/functional parts covered under this limited warranty.

**The cost of repair or replacement under these excluded circumstances shall be borne by the consumer.**

TO OBTAIN WARRANTY SERVICE AND ADDITIONAL INFORMATION Call 1-800-243-0000 and select the appropriate option from the menu. Or visit our website at <http://www.lg.com>. Or by mail: LG Electronics Customer Service P.O. Box 240007 Huntsville, AL 35813 ATTN: CIC

## LIMITED WARRANTY

### PROCEDURE FOR RESOLVING DISPUTES:

ALL DISPUTES BETWEEN YOU AND LG ARISING OUT OF OR RELATING IN ANY WAY TO THIS LIMITED WARRANTY OR THE PRODUCT SHALL BE RESOLVED EXCLUSIVELY THROUGH BINDING ARBITRATION, AND NOT IN A COURT OF GENERAL JURISDICTION. BINDING ARBITRATION MEANS THAT YOU AND LG ARE EACH WAIVING THE RIGHT TO A JURY TRIAL AND TO BRING OR PARTICIPATE IN A CLASS ACTION.

**Definitions.** For the purposes of this section, references to "LG" mean LG Electronics U.S.A., Inc., its parents, subsidiaries and affiliates, and each of their officers, directors, employees, agents, beneficiaries, predecessors in interest, successors, assigns and suppliers; references to "dispute" or "claim" shall include any dispute, claim or controversy of any kind whatsoever (whether based in contract, tort, statute, regulation, ordinance, fraud, misrepresentation or any other legal or equitable theory) arising out of or relating in any way to the sale, condition or performance of the product or this Limited Warranty.

**Notice of Dispute.** In the event you intend to commence an arbitration proceeding, you must first notify LG in writing at least 30 days in advance of initiating the arbitration by sending a letter to LG at LG Electronics, USA, Inc. Attn: Legal Department-Arbitration 1000 Sylvan Ave, Englewood Cliffs 07632. You and LG agree to engage in good faith discussions in an attempt to amicably resolve your claim. The notice must provide your name, address, and telephone number; identify the product that is the subject of the claim; and describe the nature of the claim and the relief being sought. If you and LG are unable to resolve the dispute within 30 days, either party may proceed to file a claim for arbitration.

**Agreement to Binding Arbitration and Class Action Waiver.** Upon failure to resolve the dispute during the 30 day period after sending written notice to LG, you and LG agree to resolve any claims between us only by binding arbitration on an individual basis, unless you opt out as provided below. Any dispute between you and LG shall not be combined or consolidated with a dispute involving any other person's or entity's product or claim. More specifically, without limitation of the foregoing, any dispute between you and LG shall not under any circumstances proceed as part of a class or representative action. Instead of arbitration, either party may bring an individual action in small claims court, but that small claims court action may not be brought on a class or representative basis.

**Arbitration Rules and Procedures.** To begin arbitration of a claim, either you or LG must make a written demand for arbitration. The arbitration will be administered by the American Arbitration Association ("AAA") and will be conducted before a single arbitrator under the AAA's Consumer Arbitration Rules that are in effect at the time the arbitration is initiated (referred to as the "AAA Rules") and under the procedures set forth in this section. The AAA Rules are available online at [www.adr.org/consumer](http://www.adr.org/consumer). Send a copy of your written demand for arbitration, as well as a copy of this provision, to the AAA in the manner described in the AAA Rules. You must also send a copy of your written demand to LG at LG Electronics, USA, Inc. Attn: Legal Department- Arbitration 1000 Sylvan Avenue Englewood Cliffs, NJ 07632. If there is a conflict between the AAA Rules and the rules set forth in this section, the rules set forth in this section will govern. This arbitration provision is governed by the Federal Arbitration Act. Judgment may be entered on the arbitrator's award in any court of competent jurisdiction. All issues are for the arbitrator to decide, except that issues relating to the scope and enforceability of the arbitration provision and to the arbitrability of the dispute are for the court to decide. The arbitrator is bound by the terms of this provision.

**Governing Law.** The law of the state of your residence shall govern this Limited Warranty and any disputes between us except to the extent that such law is preempted by or inconsistent with applicable federal law.

**Fees/Costs.** You do not need to pay any fee to begin an arbitration. Upon receipt of your written demand for AAA unless you seek more than \$25,000 in damages, in which case the payment of these fees will be governed by the AAA Rules. Except as otherwise provided for herein, LG will pay AAA filing, administration and arbitrator fees for any arbitration initiated in accordance with the AAA Rules and this arbitration provision. If you prevail in the arbitration, LG will pay your attorneys' fees and expenses as long as they are reasonable, by considering factors including, but not limited to, the purchase amount and claim amount. Notwithstanding the foregoing, if applicable law allows for an award of reasonable attorneys' fees and expenses, an arbitrator can award them to the same extent that a court would. If the arbitrator finds either the substance of your claim or the relief sought in the demand is frivolous or brought for an improper purpose (as measured by the standards set forth in Federal Rule of Civil Procedure 11(b)), then the payment of all arbitration fees will be governed by the AAA Rules. In such a situation, you agree to reimburse LG for all monies previously disbursed by it that are otherwise your obligation to pay under the AAA Rules. Except as otherwise provided for, LG waives any rights it may have to seek attorneys' fees and expenses from you if LG prevails in the arbitration.

**Hearings and Location.** If your claim is for \$25,000 or less, you may choose to have the arbitration conducted solely on the basis of (1) documents submitted to the arbitrator, (2) through a telephonic hearing, or (3) by an in-person hearing as established by the AAA Rules. If your claim exceeds \$25,000, the right to a hearing will be determined by the AAA Rules. Any in-person arbitration hearings will be held at a location within the federal judicial district in which you reside unless we both agree to another location or we agree to a telephonic arbitration.

**Opt Out.** You may opt out of this dispute resolution procedure. If you opt out, neither you nor LG can require the other to participate in an arbitration proceeding. To opt out, you must send notice to LG no later than 30 calendar days from the date of the first consumer purchaser's purchase of the product by either: (i) sending an e-mail to [optout@lge.com](mailto:optout@lge.com), with the subject line: "Arbitration Opt Out" or (ii) calling 1-800-980-2973. You must include in the opt out e-mail or provide by telephone: (a) your name and address; (b) the date on which the product was purchased; (c) the product model name or model number; and (d) the serial number (the serial number can be found (i) on the product; or (ii) online by accessing <https://www.lg.com/us/support/repair-service/schedule-repair-continued> and clicking on "Find My Model & Serial Number").

You may only opt out of the dispute resolution procedure in the manner described above (that is, by e-mail or telephone); no other form of notice will be effective to opt out of this dispute resolution procedure. Opting out of this dispute resolution procedure will not affect the coverage of the Limited Warranty in any way, and you will continue to enjoy the full benefits of the Limited Warranty. If you keep this product and do not opt out, then you accept all terms and conditions of the arbitration provision described above.

# LIMITED WARRANTY

LG ELECTRONICS CANADA, INC.  
LG REFRIGERATOR LIMITED WARRANTY - Canada

**ARBITRATION NOTICE: THIS LIMITED WARRANTY CONTAINS AN ARBITRATION PROVISION THAT REQUIRES YOU AND LG TO RESOLVE DISPUTES BY BINDING ARBITRATION INSTEAD OF IN COURT, UNLESS THE LAWS OF YOUR PROVINCE OR TERRITORY DO NOT PERMIT THAT, OR, IN OTHER JURISDICTIONS, IF YOU CHOOSE TO OPT OUT. IN ARBITRATION, CLASS ACTIONS AND JURY TRIALS ARE NOT PERMITTED. PLEASE SEE THE SECTION TITLED "PROCEDURE FOR RESOLVING DISPUTES" BELOW.**

Should your LG Refrigerator ("Product") fail due to a defect in materials or workmanship under normal and proper use, during the warranty period set forth below, LG Electronics Canada, Inc. ("LGECI") will, at its option, repair or replace the Product upon receipt of proof of the original retail purchase. This limited warranty is valid only to the original retail purchaser of the Product and applies only to a Product distributed, purchased and used within Canada, as determined at the sole discretion of LGECI.

<b>WARRANTY PERIOD (Note: If the original date of purchase cannot be verified, the warranty will begin sixty (60) days from the date of manufacture)</b>			
<b>Refrigerator</b>	<b>Sealed System (Condenser, Dryer, Connecting Tube and Evaporator)</b>		<b>Linear / Inverter Compressor</b>
<b>One (1) year from the date of original retail purchase</b>	<b>One (1) year from the date of original retail purchase</b>	<b>Seven (7) years from the date of original retail purchase</b>	<b>Ten (10) years from the date of original retail purchase</b>
Parts and Labor (internal/functional parts only)	Parts and Labor	Parts only (Consumer will be charged for labor)	Part only (Consumer will be charged for labor)

- Replacement products and parts are warranted for the remaining portion of the original warranty period or ninety (90) days, whichever is greater.
- Replacement products and parts may be new, reconditioned, refurbished, or otherwise factory remanufactured, all at the sole discretion of LGECI.
- Proof of original retail purchase specifying the Product model and date of purchase is required to obtain warranty service under this Limited Warranty.

**LGECI'S SOLE LIABILITY IS LIMITED TO THE LIMITED WARRANTY SET OUT ABOVE. EXCEPT AS EXPRESSLY PROVIDED ABOVE, LGECI MAKES NO, AND HEREBY DISCLAIMS, ALL OTHER WARRANTIES AND CONDITIONS RESPECTING THE PRODUCT, WHETHER EXPRESS OR IMPLIED, INCLUDING BUT NOT LIMITED TO, ANY IMPLIED WARRANTY OR CONDITION OF MERCHANTABILITY OR FITNESS FOR A PARTICULAR PURPOSE, AND NO REPRESENTATIONS SHALL BE BINDING ON LGECI. LGECI DOES NOT AUTHORIZE ANY PERSON TO CREATE OR ASSUME FOR IT ANY OTHER WARRANTY OBLIGATION OR LIABILITY IN CONNECTION WITH THE PRODUCT. TO THE EXTENT THAT ANY WARRANTY OR CONDITION IS IMPLIED BY LAW, IT IS LIMITED TO THE WARRANTY PERIOD SET OUT ABOVE. UNDER NO CIRCUMSTANCES SHALL LGECI, THE MANUFACTURER OR DISTRIBUTOR OF THE PRODUCT, BE LIABLE FOR ANY INCIDENTAL, CONSEQUENTIAL, SPECIAL, DIRECT, INDIRECT, PUNITIVE OR EXEMPLARY DAMAGES, INCLUDING, WITHOUT LIMITATION, LOSS OF GOODWILL, LOST PROFITS, LOSS OF ANTICIPATED PROFITS, LOST REVENUE, LOSS OF USE, OR ANY OTHER DAMAGE, WHETHER ARISING DIRECTLY OR INDIRECTLY FROM ANY CONTRACTUAL BREACH, FUNDAMENTAL BREACH, TORT OR OTHERWISE, OR FROM ANY ACTS OR OMISSIONS. LGECI'S TOTAL LIABILITY, IF ANY, SHALL NOT EXCEED THE PURCHASE PRICE PAID BY YOU FOR THE PRODUCT.**

This Limited Warranty gives you specific legal rights. You may also have other rights that vary from province to province depending on applicable provincial laws. Any term of this Limited Warranty that negates or varies any implied condition or warranty under provincial law is severable where it conflicts with such provincial law without affecting the remainder of this warranty's terms.

**THIS LIMITED WARRANTY DOES NOT COVER:**

- Service trips to i) deliver, pick up, or install or; educate on how to operate the Product; ii) correct wiring or plumbing; or iii) correct unauthorized repairs or installations of the Product;
- Damage or failure of the Product to perform during power failures and interrupted or inadequate electrical service;
- Damage or failure caused by leaky or broken water pipes, frozen water pipes, restricted drain lines, inadequate or interrupted water supply or inadequate supply of air;
- Damage or failure resulting from operating the Product in a corrosive atmosphere or contrary to the instructions outlined in the Product's owner's manual;
- Damage or failure to the Product caused by accidents, pests and vermin, lightning, wind, fire, floods, acts of God, or any other causes beyond the control of LGECI or the manufacturer;
- Damage or failure resulting from misuse, abuse, improper installation, repair, or maintenance of the Product. Improper repair includes use of parts not authorized or specified by LGECI. Improper installation or maintenance includes installation or maintenance contrary to the Product's owner's manual;
- Damage or failure caused by unauthorized modification or alteration of the Product, or if used for other than the intended household purpose/use of the Product, or damage or failure resulting from any water leakage due to improper installation of the Product;
- Damage or failure caused by incorrect electrical current, voltage or plumbing codes;
- Damage or failure caused by use that is other than normal household use, including, without limitation, commercial or industrial use, including use in commercial offices or recreational facilities, or as otherwise outlined in the Product's owner's manual;
- Damage or failure caused by the use of any accessories, components or cleaning products, including, without limitation, water filters, that are not approved/authorized by LGECI;
- Replacement of the water filter cartridge due to water pressure that is outside the specified operating range or due to excessive sediment in the water supply;
- Damage or failure caused by transportation and handling, including scratches, dents, chips and/or other damage to the finish of the Product, **unless** such damage results from defects in materials or workmanship and is reported to LGECI within one (1) week of delivery of the Products;
- Damage or missing items to any display, open box, refurbished or discounted Product;
- Refurbished Product or any Product sold "As Is", "Where Is", "With all Faults", or any similar disclaimer;
- Products with original serial numbers that have been removed, altered or cannot be readily determined at the discretion of LGECI;
- Increases in utility costs and additional utility expenses in any way associated with the Product;

## LIMITED WARRANTY

- Any noises associated with normal operation of the Product;
  - Replacement of light bulbs, filters, fuses or any other consumable parts;
  - Replacement of any part that was not originally included with the Product;
  - Costs associated with removal and/or reinstallation of the Product for repairs; and
  - Shelves, door bins, drawers, handle and accessories to the Product, except for internal/functional parts covered under this Limited Warranty.
- Coverage for "in Home" repairs, for products in-warranty, will be provided if the Product is within a 150 km radius from the nearest authorized service center (ASC), as determined by LG Canada. If your Product is located outside a 150 km radius from a ASC, as determined by LG Canada, it will be your responsibility to bring the Product, at your sole expense, to the ASC for in-warranty repair.

**All costs and expenses associated with the above excluded circumstances, listed under the heading, This Limited Warranty Does Not Cover, shall be borne by the consumer.** TO OBTAIN WARRANTY SERVICE AND ADDITIONAL INFORMATION, PLEASE CALL OR VISIT OUR WEBSITE: Call 1-888-542-2623 (7 A.M. to 12 A.M., 365 days a year) and select the appropriate option from the menu, or. Visit our website at <http://www.lg.com>

### PROCEDURE FOR RESOLVING DISPUTES:

EXCEPT WHERE PROHIBITED AT LAW, ALL DISPUTES BETWEEN YOU AND LG ARISING OUT OF OR RELATING IN ANY WAY TO THIS LIMITED WARRANTY OR THE PRODUCT SHALL BE RESOLVED EXCLUSIVELY THROUGH BINDING ARBITRATION, AND NOT IN A COURT OF GENERAL JURISDICTION. EXCEPT WHERE PROHIBITED AT LAW, YOU AND LG BOTH IRREVOCABLY AGREE TO WAIVE THE RIGHT TO A JURY TRIAL AND TO BRING OR PARTICIPATE IN A CLASS ACTION.

**Definitions.** For the purposes of this section, references to "LG" mean LG Electronics Canada, Inc., its parents, subsidiaries and affiliates, and each of their officers, directors, employees, agents, beneficiaries, predecessors in interest, successors, assigns and suppliers; references to "dispute" or "claim" shall include any dispute, claim or controversy of any kind whatsoever (whether based in contract, tort, statute, regulation, ordinance, fraud, misrepresentation or any other legal or equitable theory) arising out of or relating in any way to the sale, condition or performance of the product or this Limited Warranty.

**Notice of Dispute.** In the event you intend to commence an arbitration proceeding, you must first notify LG in writing at least 30 days in advance of initiating the arbitration by sending a letter to LGECI Legal Team at 20 Norelco Drive, North York, Ontario, Canada M9L 2X6 (the "Notice of Dispute"). You and LG agree to engage in good faith discussions in an attempt to amicably resolve your claim. The notice must provide your name, address, and telephone number; identify the product that is the subject of the claim; and describe the nature of the claim and the relief being sought. If you and LG are unable to resolve the dispute within 30 days of LG's receipt of the Notice of Dispute, the dispute shall be resolved by binding arbitration in accordance with the procedure set out herein. You and LG both agree that, during the arbitration proceeding, the terms (including any amount) of any settlement offer made by either you or LG will not be disclosed to the arbitrator until the arbitrator determines the dispute.

**Agreement to Binding Arbitration and Class Action Waiver.** Upon failure to resolve the dispute during the 30 day period after LG's receipt of the Notice of Dispute, you and LG agree to resolve any claims between you and LG only by binding arbitration on an individual basis, unless you opt out as provided below, or you reside in a jurisdiction that prevents full application of this clause in the circumstances of the claims at issue (in which case if you are a consumer, this clause will only apply if you expressly agree to the arbitration). To the extent permitted by applicable law, any dispute between you and LG shall not be combined or consolidated with a dispute involving any other person's or entity's product or claim. More specifically, without limitation of the foregoing, except to the extent such a prohibition is not permitted at law, any dispute between you and LG shall not under any circumstances proceed as part of a class or representative action. Instead of arbitration, either party may bring an individual action in small claims court, but that small claims court action may not be brought on a class or representative basis except to the extent this prohibition is not permitted at law in your province or territory of jurisdiction as it relates to the claims at issue between you and LG.

**Arbitration Rules and Procedures.** To begin arbitration of a claim, either you or LG must make a written demand for arbitration. The arbitration will be private and confidential, and conducted on a simplified and expedited basis before a single arbitrator chosen by the parties under the provincial or territorial commercial arbitration law and rules of the province or territory of your residence. You must also send a copy of your written demand to LG at LG Electronics, Canada, Inc., Attn: Legal Department-Arbitration, 20 Norelco Drive, North York, Ontario M9L 2X6. This arbitration provision is governed by your applicable provincial or territorial commercial arbitration legislation. Judgment may be entered on the arbitrator's award in any court of competent jurisdiction. All issues are for the arbitrator to decide, except that, issues relating to the scope and enforceability of the arbitration provision and to the arbitrability of the dispute are for the court to decide. The arbitrator is bound by the terms of this provision.

**Governing Law.** The law of the province or territory of your purchase shall govern this Limited Warranty and any disputes between you and LG except to the extent that such law is preempted by or inconsistent with applicable federal or provincial/territorial law. Should arbitration not be permitted for any claim, action, dispute or controversy between you and LG, you and LG attest to the exclusive jurisdiction of the courts of the province or territory of your purchase for the resolution of the claim, action, dispute or controversy between you and LG.

**Fees/Costs.** You do not need to pay any fee to begin an arbitration. Upon receipt of your written demand for arbitration, LG will promptly pay all arbitration filing fees unless you seek more than \$25,000 in damages, in which case the payment of these fees will be governed by the applicable arbitration rules. Except as otherwise provided for herein, LG will pay all filing, administration and arbitrator fees for any arbitration initiated in accordance with the applicable arbitration rules and this arbitration provision. If you prevail in the arbitration, LG will pay your attorneys' fees and expenses as long as they are reasonable, by considering factors including, but not limited to, the purchase amount and claim amount. Notwithstanding the foregoing, if applicable law allows for an award of reasonable attorneys' fees and expenses, an arbitrator can award them to the same extent that a court would. If the arbitrator finds either the substance of your claim or the relief sought in the demand is frivolous or brought for an improper purpose (as measured by the applicable laws), then the payment of all arbitration fees will be governed by the applicable arbitration rules. In such a situation, you agree to reimburse LG for all monies previously disbursed by it that are otherwise your obligation to pay under the applicable arbitration rules. Except as otherwise provided for, LG waives any rights it may have to seek attorneys' fees and expenses from you if LG prevails in the arbitration.

**Hearings and Location.** If your claim is for \$25,000 or less, you may choose to have the arbitration conducted solely (1) on the basis of documents submitted to the arbitrator, (2) through a telephonic hearing, or (3) by an in-person hearing as established

## LIMITED WARRANTY

by the applicable arbitration rules. If your claim exceeds \$25,000, the right to a hearing will be determined by the applicable arbitration rules. Any in-person arbitration hearings will be held at the nearest, most mutually-convenient arbitration location available within the province or territory in which you reside unless you and LG both agree to another location or agree to a telephonic arbitration.

**Severability and Waiver.** If any portion of this Limited Warranty (including these arbitration procedures) is unenforceable, the remaining provisions will continue in full force and effect to the maximum extent permitted by applicable law. Should LG fail to enforce strict performance of any provision of this Limited Warranty (including these arbitration procedures), it does not mean that LG intends to waive or has waived any provision or part of this Limited Warranty.

**Opt Out.** You may opt out of this dispute resolution procedure. If you opt out, neither you nor LG can require the other to participate in an arbitration proceeding. To opt out, you must send notice to LG no later than 30 calendar days from the date of the first consumer purchaser's purchase of the product by either (i) sending an e-mail to [optout@lge.com](mailto:optout@lge.com), with the subject line: "Arbitration Opt Out;" or (ii) calling 1-800-980-2973. You must include in the opt out e-mail or provide by telephone: (a) your name and address; (b) the date on which the product was purchased; (c) the product model name or model number; and (d) the serial number (the serial number can be found (i) on the product; or (ii) online by accessing [https://www.lg.com/ca\\_en/support/repair-service/schedule-repair](https://www.lg.com/ca_en/support/repair-service/schedule-repair) and clicking on "Find My Model & Serial Number").

In the event that you "Opt Out", the law of the province or territory of your residence shall govern this Limited Warranty and any disputes between you and LG except to the extent that such law is preempted by or inconsistent with applicable federal or provincial/territorial law. Should arbitration not be permitted for any claim, action, dispute or controversy between you and LG, you and LG agree to attorn to the exclusive jurisdiction of the courts of the province or territory of your residence for the resolution of the claim, action, dispute or controversy between you and LG. You may only opt out of the dispute resolution procedure in the manner described above (that is, by e-mail or telephone); no other form of notice will be effective to opt out of this dispute resolution procedure. Opting out of this dispute resolution procedure will not affect the coverage of the Limited Warranty in any way, and you will continue to enjoy the full benefits of the Limited Warranty. If you keep this product and do not opt out, then you accept all terms and conditions of the arbitration provision described above.

**Conflict of Terms.** In the event of a conflict or inconsistency between the terms of this Limited Warranty and the End User License Agreement ("EULA") in regards to dispute resolution, the terms of this Limited Warranty shall control and govern the rights and obligations of the parties and shall take precedence over the EULA.





LG Customer Information Center

<b>1-800-243-0000</b>	USA, Consumer User
<b>1-888-865-3026</b>	USA, Commercial User
<b>1-888-542-2623</b>	CANADA

Register your Product Online!

[www.lg.com](http://www.lg.com)