



ANCHEER

SPIN BIKE USER'S MANUAL



CAUTION

Read all precautions and instructions in this manual before using this equipment. Keep this manual for future reference.



Installation Video

<https://youtu.be/Iwb5uQ0RWQ0>

CONTENTS

Safety Precautions	3
Exploded View	4
Part List	5
Assembly Instructions	6
Computer Operation Instructions	10
Maintenance	11
Exercise Instructions	12
Troubleshooting	13
Warranty	14

Safety Precautions – Please Read the Instruction before Using!

1. According to the installation instruction, use original parts to assemble this product properly. Before assembly, inspect whether packages are in good condition and whether spare parts are complete in accordance with transport precautions and the list of spare parts.
2. Prior to exercise, make sure equipment fasteners are in locking state.
3. Please place the exercise bike on a dry and flat ground.
4. To prevent the bottom of the equipment from damage such as abrasion and stain, put an object such as a rubber cushion or a thin wood plate under the bottom.
5. Before starting the exercise, make sure that there is no object near the exercise bike in 0.5m.
6. Please use the attached or other appropriate tools to assemble or repair the exercise bike. After exercise, please wipe sweat off it.
7. Improper use and excessive exercise endanger your health. Please carry out your exercise plan under the direction of a doctor. He can provide you with excellent suggestions on your exercise gestures, exercise goals and your food. Never make exercise after a meal. This exercise bike is not for the medical purpose.
8. Please use the exercise bike when the equipment is in good operation. Make necessary maintenance using original spare parts.
9. When regulating the equipment, note to observe the best position and largest adjustable position to ensure the adjusted position is safe.
10. Unless otherwise specified in the instruction, this exercise bike is only for use by one person at one time.
11. During exercise, please wear sports cloths and shoes. The clothes shall not be too long and too wide so as to prevent them from being hooked or hung during exercise. The shoes must be suited for the feet and the soles shall be anti-slip.
12. When feeling uncomfortable during the process, please stop exercise immediately, and when necessary, consult a doctor.
13. The sports equipment is not the toy to play with, and thus, it shall be used by those people for exercise purpose.
14. Children and disabled persons shall use the equipment in the presence of adults or healthy people. Appropriate measures shall be taken to ensure a child is unable to use the equipment without the supervision of an adult.
15. Make sure any part of another person will not be accessible to the equipment during the exercise.
16. To protect the environment, never discard packages or batteries, and please put them into a designated dustbin or other waste collection point.
17. The exercise bike has a maximum load of 120KG.

EXPLODED

VIEW

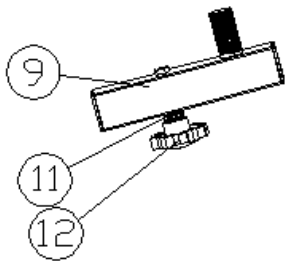
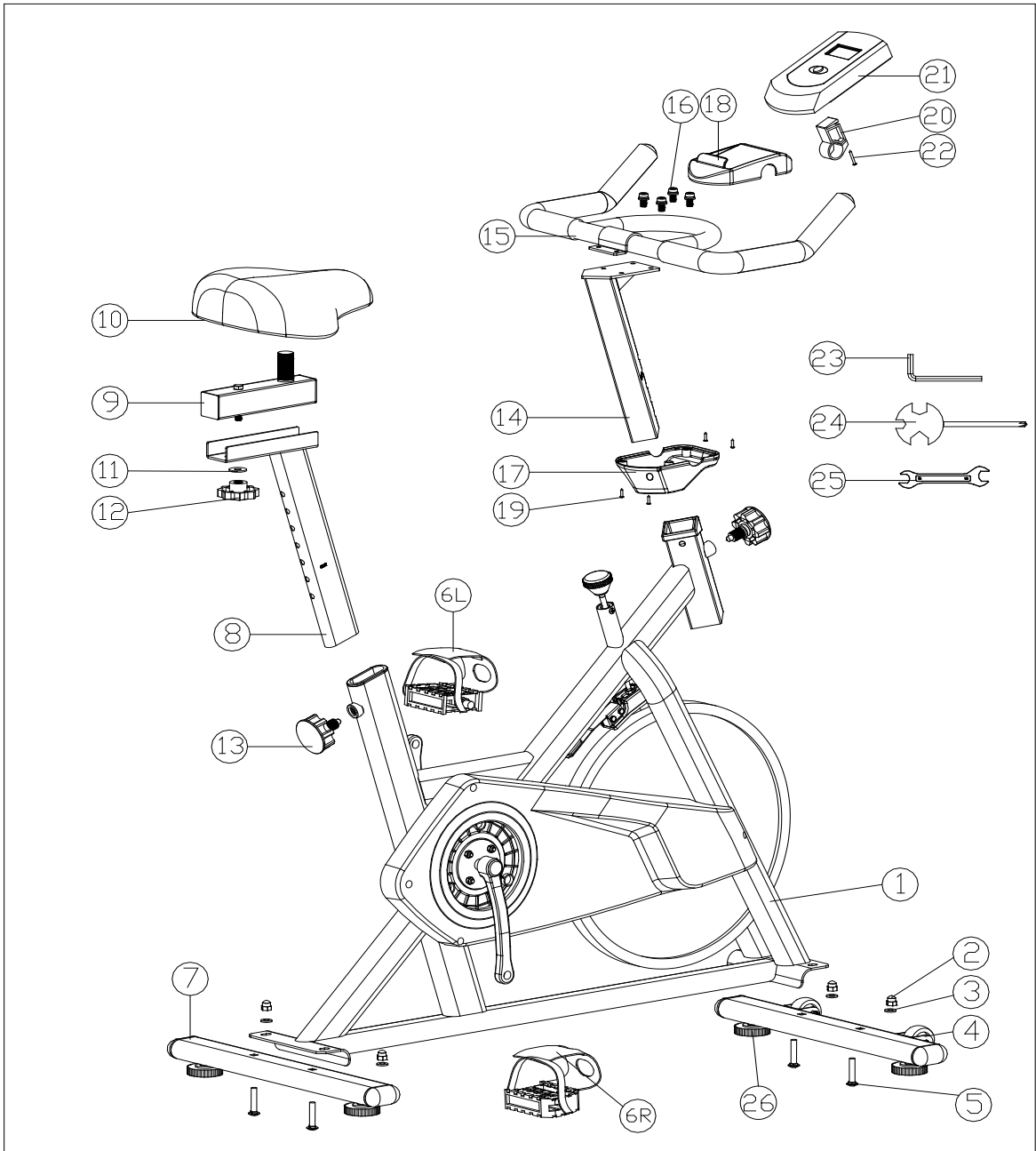

Part #11 and #12 are pre-fitted
on Part #9

Part #16 are pre-fitted
on Part #14



Ø8 Flat Washer



M8 Cap Nut

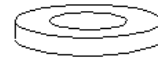

Ø10 Flat Washer



M8*16 Combination Screw

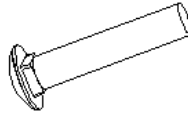

M5*45 Carriage Bolts



M4*20 Self-Tapping Screw



13-15 Wrench

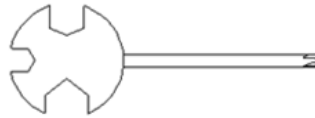

Multi-function Wrench (Screwdriver)



L shape Wrench

PART LIST

NO.	DESCRIPTION	QTY	NO.	DESCRIPTION	QTY
1	Main Frame	1	14	Handle Support Tub	1
2	M8 Cap Nut	4	15	Handlebar	1
3	Ø8 Flat Washer	4	16	M8*16 Combination Screw	4
4	Front Stabilizer	1	17	Mobile Holder Lower	1
5	M5*45 Carriage Bolt	4	18	Mobile Holder Upper	1
6	Pedal L/R	2	19	M4*12 Screw	4
7	Rear Stabilizer	1	20	Computer Bracket	1
8	Seat Support Tube	1	21	Computer	1
9	Horizontal Sliding Bar	1	22	M4*20 Self-Tapping Screw	1
10	Saddle	1	23	L Shape Wrench	1
11	Ø10 Flat Washer	1	24	Multi-function Wrench (Screwdriver)	1
12	M10 Lock Knob	1	25	13-15 Wrench	1
13	M16 Lock Knob		26	Adjustable Foot	4

ASSEMBLY INSTRUCTIONS

4 easy steps to assemble then you're ready to workout - it takes approx 30 mins to assemble.

STEP 1

- a. Fix the Front Stabilizer (4) to Main frame (1) using 2 X M5*45 Carriage Bolts (5), 2 X Ø8 Flat Washers (3) and 2 X M8 Cap Nuts (2) provided.
- b. Repeat Step a. to install Rear Stabilizer (7) to Main Frame (1).
- c. First take the thread of Pedal L to direct vertically to crank L, then firmly fix the left Pedal (6L) to the crank arm marked L in a anti-clockwise direction by 13-15 wrench until tight.
- d. Now take the thread of Pedal R to direct vertically to crank R, then firmly fix the right Pedal (6R) to the crank arm marked R in a clockwise direction by 13-15 wrench until tight.

Failure to follow the above instructions could result in damage to the cranks and pedals.

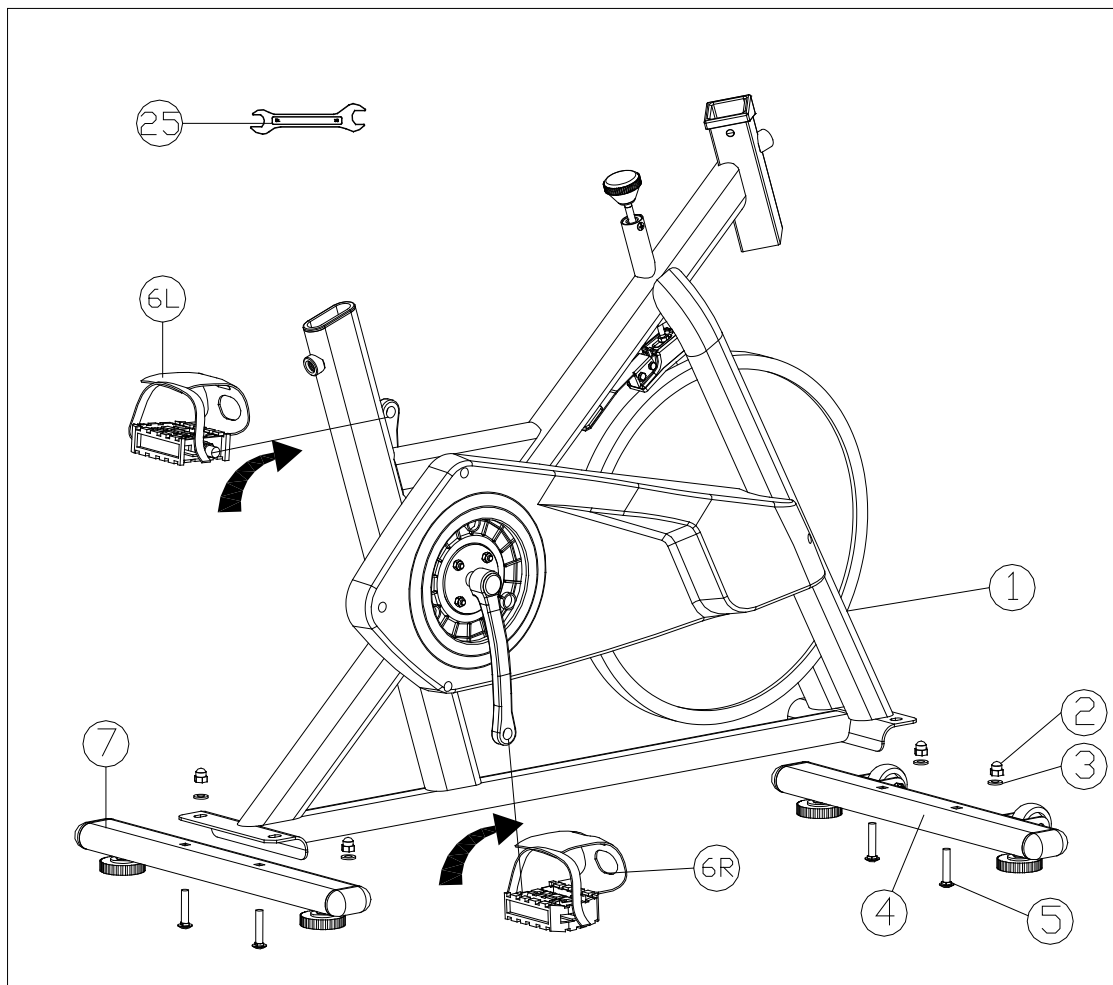

STEP 2

- a. Insert the Seat Support Tube (8) to the rear opening tube of the Main Frame (1).
- b. Adjust the Seat Support Tube (8) to your desired height, then refit and tighten the M16 Lock Knob (13).
- c. Attach the Horizontal Sliding Bar (9) onto the Seat Support Tube (8), secure with the M10 Lock Knob (12) and Ø10 Flat Washer (11).

Remarks: The M10 Plum Lock Knob (12) and Ø10 Flat Washer (11) are pre-fitted on the Horizontal sliding Bar (9).

- d. Select your desired forward or backward position, then tighten the M10 Lock Knob (12).
- e. Fix the Saddle (10) to the Horizontal Sliding Bar (9) with the provided 13-15 Wrench until tight.

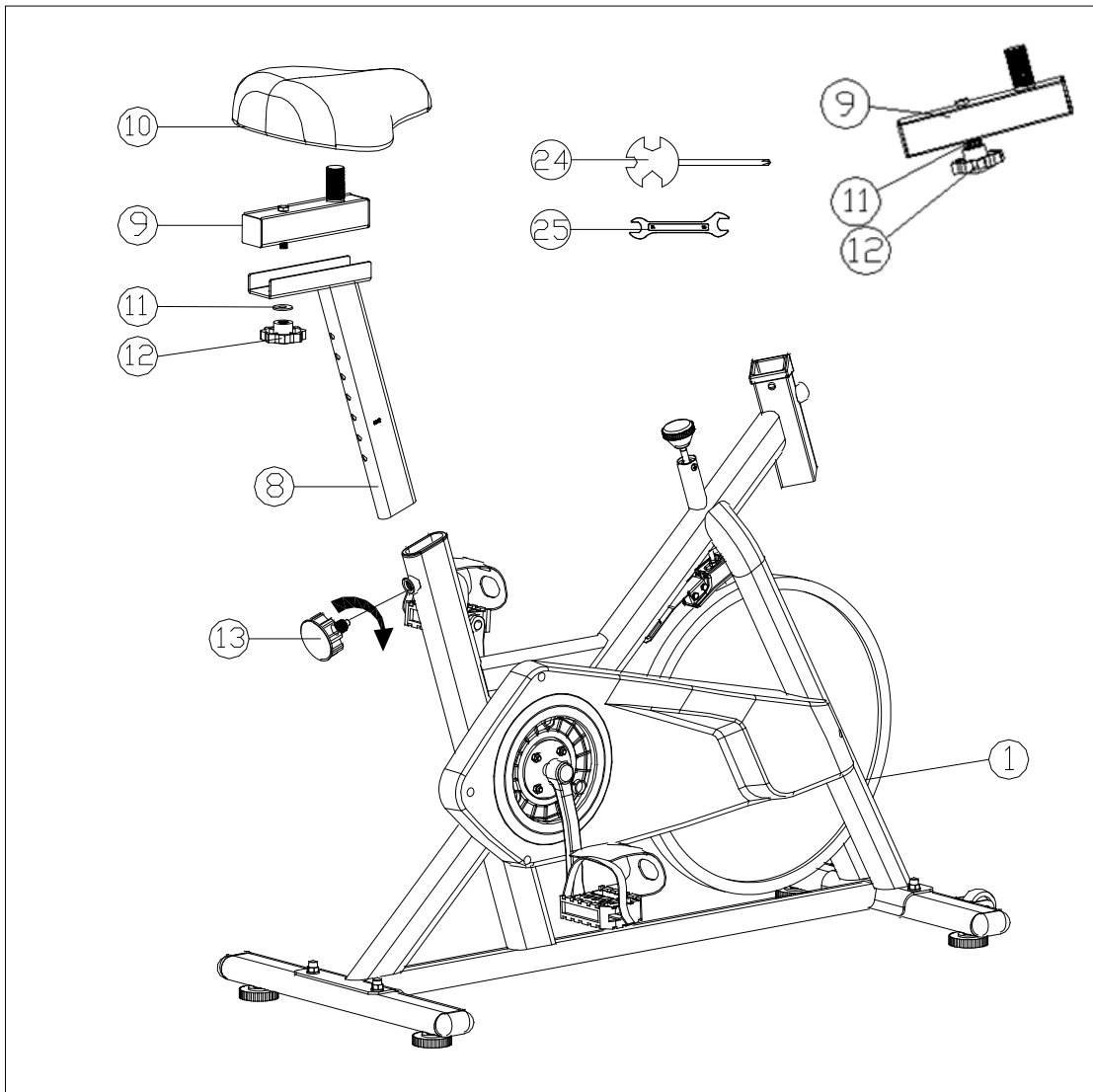

STEP 3

- a. Insert the handlebar support tube (14) into the lower part of the mobile holder (17), then into the front opening tube of the frame (1), to tighten with the M16 Lock Knob (13).
- b. First loose 4 X M8*16 Combination Screws (16) fixed on the handlebar support tube (14), then fix the Handlebar (15) to the Handlebar Support Tube (14) with 4 X M8*16 Combination Screws (16) to tight by L Shape Wrench (23).

Remarks: 4 X M8*16 Combination Screws (16) are pre-fitted on the Handlebar Support Tube (14).

- c. Connect the Mobile Holder Upper (18) with the Mobile Holder Lower part (17) with M4*12 Screws (19) by Screwdriver (24).

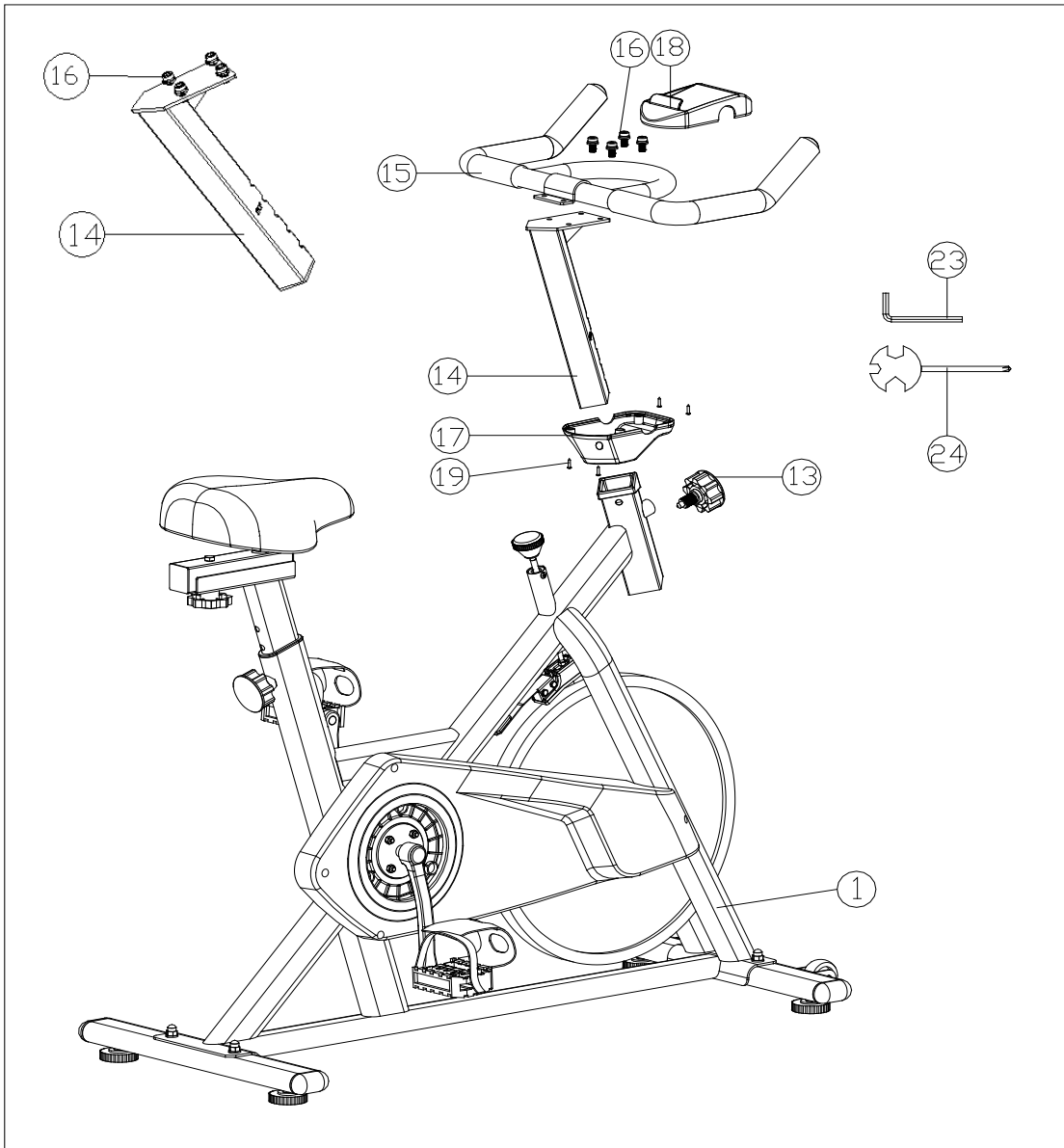

STEP 4

- a. Attach Computer Bracket (20) on the Handlebar (15) fasten with Self-Tapping Screw (22) by the provided Multi-function Wrench (Screwdriver) (24).
- b. Insert the Computer Bracket (20) into the flute on the back of the Computer (21). Then remember to load the 2AA batteries, and insert the sensor wire from the main frame (21-1) into "SENSOR INPUT" hole (21-1) on the back of the computer.

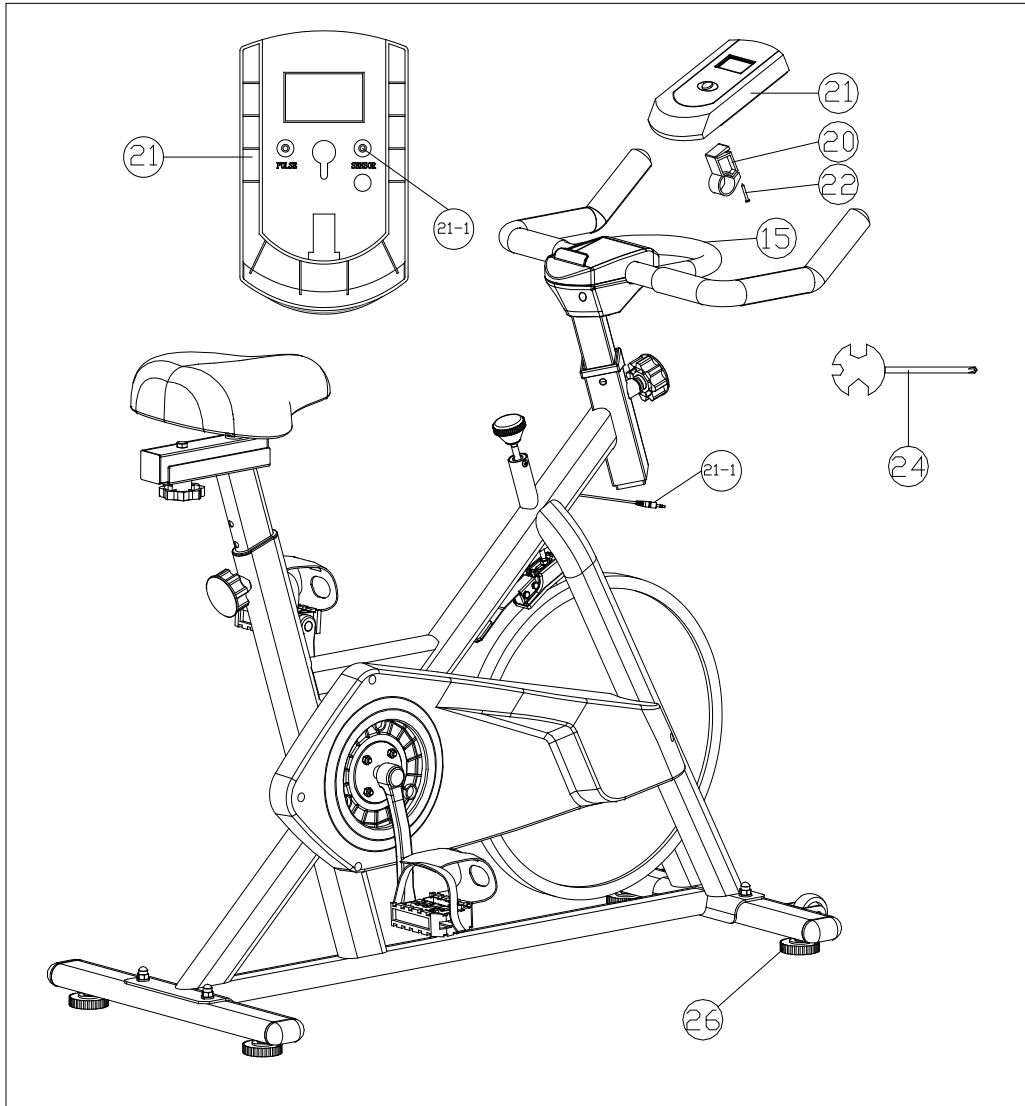

Most Important

After all above 4 steps finished, the most important thing is to make sure all the bolts and parts are securely fixed before you are riding on the bike.

COMPUTER OPERATION INSTRUCTIONS



SCAN	Scans all functions - TIME, SPEED, DISTANCE, TOTAL DIST, CALORIES
TIME	Displays work out time lapse while exercising
SPEED	Displays the current speed
DISTANCE	Displays the distance while exercising
TOTAL DIST	Displays the total distance at the end of your workout
CALORIES	Displays the calories you have burned

1. You will need to prepare one or two batteries to operate the Computer.
2. To select the function you want, press the MODE button and then select the function of choice from the table above.
3. To reset the Computer, hold down the MODE button for 5 seconds.
4. The Computer will automatically turn off after 4 minutes when the bike is not in use. Press any key to restart.
5. To adjust the resistance, turn the tension control to the right (harder), or to the left (easier) .
6. If there is an improper display on the Computer, please replace both batteries with new ones at the same time.
7. To move the bike, hold onto the saddle support pole, lift and push forward.

MAINTENANCE

Regular maintenance will prolong the life of your spin bike and prevent injury. We strongly recommend that you do the following on a regular basis:

1. Clean the bike after use with a soft cloth - ensure it is dry. Note, a build up of moisture over time will cause corrosion.
2. Clean the Computer display with a soft cloth and anti-static computer spray to remove dust or finger prints. **Note**, harsh chemicals will destroy the protective coating on the computer and cause a static build up inside the computer that could damage the components.
3. Check the front and back stabilizers each time you use the bike to ensure the bike is stable and the level with the floor.
4. Check and tighten loose nuts/buts, the saddle adjustment locks, pedals, and handlebars to ensure they are secure each time you use the bike to avoid injury.
5. A spent battery is hazardous waste, please dispose of it correctly, and do not throw it in the trash.
6. For replacement parts, contact the distributor.

EXERCISE INSTRUCTIONS

Using your EXERCISE CYCLE will provide you several benefits, it will improve your physical fitness, tone your muscle, and in conjunction with calorie controlled diet, it will help you lose weight.

1. The Warm Up Phase

This stage helps the blood flow around the body and the muscles work properly. It will also reduce the risk of cramp and muscle injury. It is advisable to do a few stretching exercises as shown below. Each stretch should be held for approximately 30 seconds, do not force or jerk your muscles into a stretch - if it hurts, STOP.

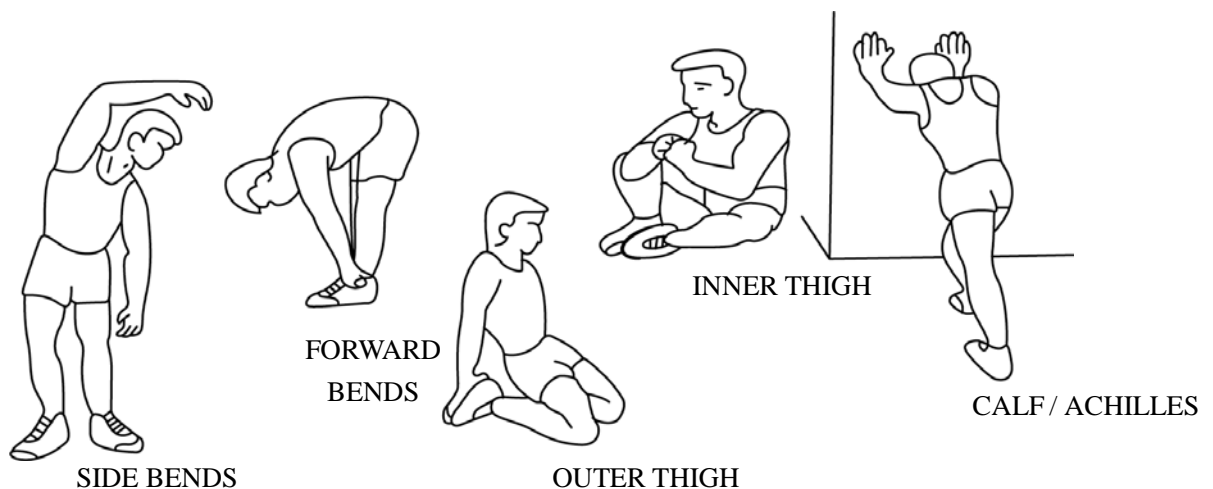

2. The Exercise Phase

This is the stage where you put the effort in. After regular use, the muscles in your legs will become more flexible. Work to your own pace but it is very important to maintain a steady tempo throughout. The rate of work should be sufficient to raise your heart beat into the target zone shown on the graph below.

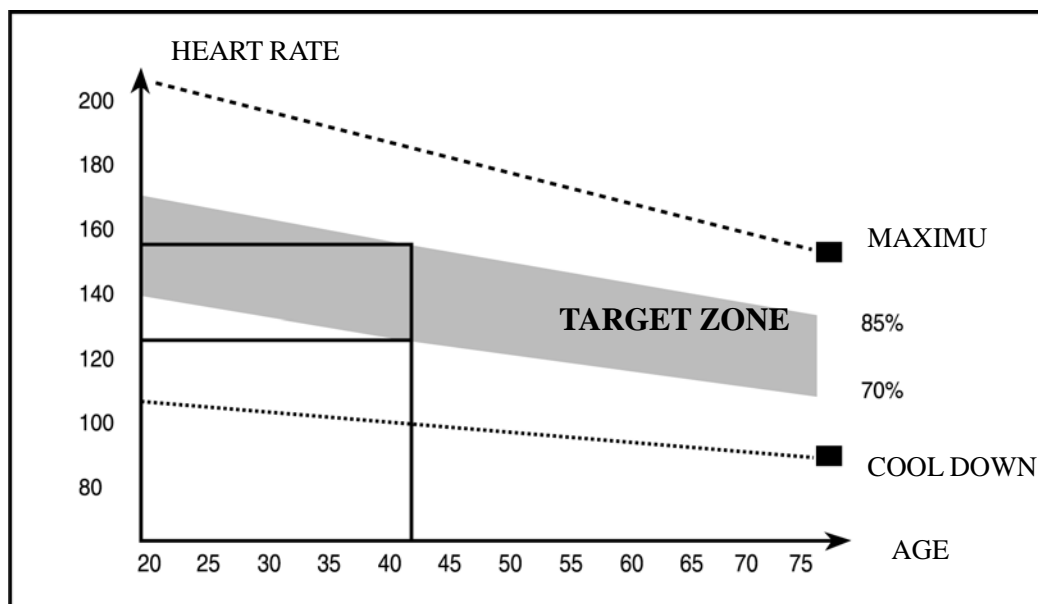

TROUBLESHOOTING

REF	PROBLEM	SOLUTION
1	THE PEDALS ARE SPINNING OUT OF CONTROL	<ol style="list-style-type: none"> 1. PRESS THE RED EMERGENCY STOP LEVER. 2. ADD MORE RESISTANCE BY TURNING THE TENSION CONTROL TO THE RIGHT. 3. START PEDALLING SLOWLY. 4. KEEP TURNING THE TENSION CONTROL TO THE RIGHT UNTIL YOU CAN FEEL RESISTANCE WHEN YOU PEDAL.
2	THE BIKE IS UNSTABLE	<ol style="list-style-type: none"> 1. ADJUST THE FRONT AND BACK STABILIZERS UNTIL THEY ARE FLAT ON THE SURFACE. 2. SHAKE THE BIKE TO ENSURE IT'S STABLE.
3	THE HANDLEBARS ARE WOBBLY	<ol style="list-style-type: none"> 1. PRESS THE RED EMERGENCY STOP LEVER. 2. TURN THE HANDLEBAR SAFETY LOCK UNTIL TIGHT (DO THIS WHILE STANDING).
4	MY FEET BARELY TOUCH THE PEDALS	<ol style="list-style-type: none"> 1. ADJUST THE HEIGHT OF THE SADDLE BY PULLING OUT THE HEIGHT ADJUSTMENT LOCK. 2. ADJUST THE HEIGHT OF THE BIKE UNTIL THE SADDLE IS HIP HEIGHT. 3. REPEAT STEP 1 AND STEP 2 UNTIL YOUR FEET COMFORTABLY SIT INSIDE THE FOOTSTRAPS WITH YOUR LEGS SLIGHTLY BENT.
5	THE COMPUTER DOESN'T RESPOND	<ol style="list-style-type: none"> 1. REMOVE THE COMPUTER FROM THE COMPUTER BRACKET. 2. CHECK THE BATTERY IS LOADED CORRECTLY. 3. CHECK THE COMPUTER IS RESPONDING. 4. IF NOT, REMOVE THE COMPUTER WIRE AND RE-INSERT IT. 5. CHECK THE CONSOLE IS RESPONDING. 6. IF NOT, TRY REPLACING THE BATTERY. 7. OTHERWISE, CALL THE DISTRIBUTOR FOR MORE INFORMATION.

WARRANTY

1. We have one year quality warranty to the products. Within the warranty period, we provide the FREE replacement parts, and provide technical support for life.
2. If caused by incorrect assembly, incorrect use or change of parts failures, our company takes no responsibility.
3. The exercise bike is only for home use, if the problems occurred by commercial use, our company takes no responsibility.
4. After-sales service isn't restricted by time and our after-sales service staff would solve your problems immediately after receiving telephone and hearing feedback idea of users.
5. MOST IMPORTANT THING, you should show our products series no. and relative pictures or information before getting the warranty if any problem occurred.