

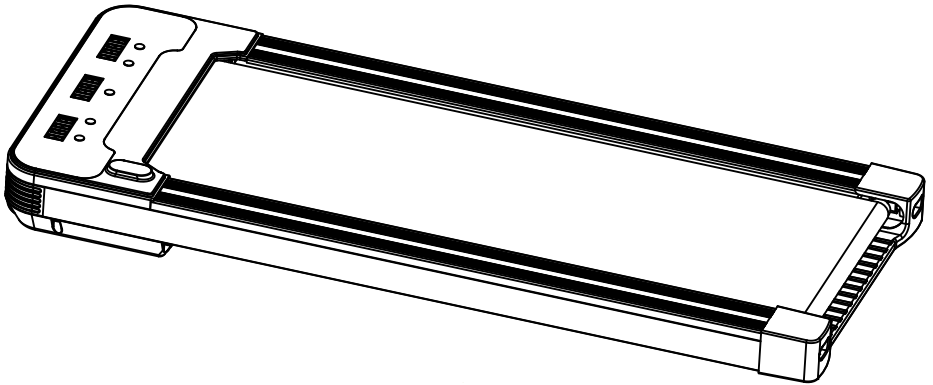

LivingEssentials
Corp.



Gamma Under Desk Electric Treadmill

SKU# ETMGY0251

Instructions Manual

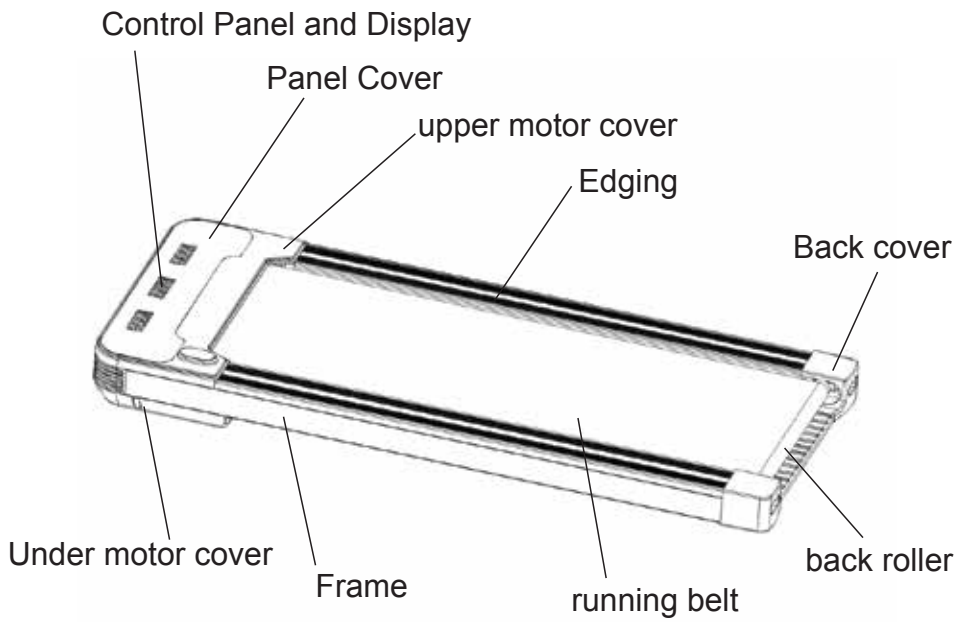

Safety cautions and warnings

Caution! Please read this manual carefully before using the product and take care to follow safety cautions below:

This treadmill should be used indoors, do not let this product be soaked and keep it away water, do not put other things on the treadmill.

Please take the proper sports gear and do warming up before use the treadmill, do not use the treadmill on bare feet.

Power plug must be grounded and use dedicated circuit, do not share circuit with other electric equipment.

Kids should stay away from the treadmill to avoid unexpected situation.

Do not use the tread mill overload and over time, or the motor, control panel, bearing, running belt and board's life will be greatly shorten. Should do the regular maintenance to keep tread mill in good state.

Reduce dust and keep certain humidity indoor to prevent electronic and control devices from interference by static electricity.

Please turn off the treadmill after using. Please make sure air circulation when you are using the treadmill.

Clamp the emergency switch to your cloth to make sure the treadmill can be stopped if meet unexpected situation.

Please stop doing exercise if you feel uncomfortable and consult your doctor.

Please keep the silicone oil away from kid after using to avoid eating accident.

Warning: To avoid accident and injured, Please read and follow precautions below:

Please check your sport gear and make sure the zipper is locked.

Do not wear cloth which is easy to be hooked by treadmill.

Do not put the power cord near heat source.

Do not let kid play with or play near tread mill.

Do not use the treadmill outdoors.

The treadmill must be unplugged before moving it.

Never try to disassemble the product if you are not professional maintainer, or it will cause very bad consequence.

The treadmill can only be used in 20A circuit.

Only one person use it at one time, do not use it with two people and more.

Please stop doing exercise if you feel dizzy, Chest pain, nausea, or shortness of breath, and consult your fitness coach or doctor.

Warning! Must !

Please consult your doctor if you are under therapy or have any one of following issues:

(1) If you are suffering waist pain or hurt leg, waist or neck before, or have perceived obstacle to leg, waist , neck and hand(also include disc herniation, Spondylolisthesis, Cervical protrusion).

(2) Deformed arthritis, rheumatism, gout.

(3) Osteoporosis or bone abnormality

(4) Circulatory system disorder(heart disease, vascular disease, high blood pressure).

(5) Respiratory organs disorder.

(6) Implant cardiac pacemaker or other electronic equipment.

(7) Malignant tumor .

(8) Thrombosis, serious arterial lipoma, acute venous lipoma and other blood circulation disease or skin infections.

(9) Perceived obstacle caused by diabetes.

(10) Wounded on skin.

(11) Sick or fever(38°C or higher temperature).

- (12) Spine abnormality or bending.
- (13) Pregnant women or women are in the menstrual period .
- (14) Unhealthy and need rest.
- (15) Obvious bad condition.
- (16) For physical recovery purpose.
- (17) Other bad feeling expect above situations.

All issues above may cause unexpected condition and may harm body. Please stop doing exercise if you feel waist pain, dizzy, Palpitations or other abnormal feeling, consult your fitness coach or doctor.

Kids must not use this product. Kid should be kept away from the product, or it may caused unexpected hurting risk.

Please make sure no other people or pet around the product when you are taking, packing or sliding the product.

! Forbidden !

Never use if you found the shell is broken and off (inside parts are exposed) or welding point is broken. Or it may cause unexpected condition.

Never jump on and off the product when you are using, it may cause falling and injured.

Never store the product outdoors, near bathroom or any place where is damp.

Never use or store the product under direct sunlight, near stove, electric blanket or other heating supply equipment, or it may cause electric shock or fire accident.

Never use the product when you found power cord or plug is broken or socket slack, or it may cause electric shock, short circuit or fire accident

Never break or twist the power cord, also never put things on the wire to avoid electric shock or fire accident

Never use the product by two or more people at the same time, keep others way when using the product, or it may cause unexpected situation or falling accident.

Never use the product if user can not express self conscious or can not operate the product by himself/herself. Or it may cause unexpected situation.

Keep the product away water or other liquid, especially the main base. Or it may cause electric shock or fire accident

Never do intense exercise if you don't exercise usually. Do not use it after meal, fatigue, or other uncomfortable state, or it may be harm to your health.

This product is only for home use, never use it at school, stadium or other public place, or it may cause unexpected situations.

Never use the product if you are eating or doing other behavior, also never use it after drinking, or it may cause accident or injured.

Never take your watch, bracelet, mobile phone and other valuable objects with you to avoid damage, also take off your keys and knife to avoid hurting yourself.

Please do check the power cord whether there is needle, garbage or other wet things before using to avoid electric shock, short circuit or fire accident

Never touch the plug with wet hand to avoid electric shock.

Please turn the power switch to off position and unplug the product if do not use it for a period to avoid electricity shock or fire accident caused by insulation deterioration

Grounding explanation

This product must be grounding, it can greatly reduce the risk of electricity shock when the product is dysfunction.

The plug of this product is grounding standard, please use local legal grounding power source to connect the product

! Dangerous !

It may cause electricity shock if the product is not grounding properly. Please ask professional electrician to check if you are not sure whether the grounding is correct. Never modify the plug if it can not fit your power source, please ask professional electrician to install a proper power source.

Never use transfer plug, this product must connect to power source with grounding function.

Parameter and packing list

Parameter					
No.	Parameter	Description			
1	Input voltage	AC110V/50-60Hz			
2	Motor power	1HP			
3	Speed	0.5-4 Mile/H			
4	Running area on belt	17"×41"			
5	Maximum load	220LBS			
6	Expanded dimension	51.5"×23.5"×6"			
7	Net weight	55 LBS			
8	Gross weight	61LBS			
9	Functions	distance , speed , time, calorie and wireless remote-control			
Packing list					
No.	Name	Quantity	No.	Name	Quantity
1	base	1pcs	2	spare parts	1pcs
Spare parts list					
No.	Name	Quantity			
1	Allen wrench (6#)	1			
2	remote-control (Include battery)	1			
3	silicone oil	1			
4	manual	1			
Multi-function model accessories list (optional)					

Remote Control Instructions

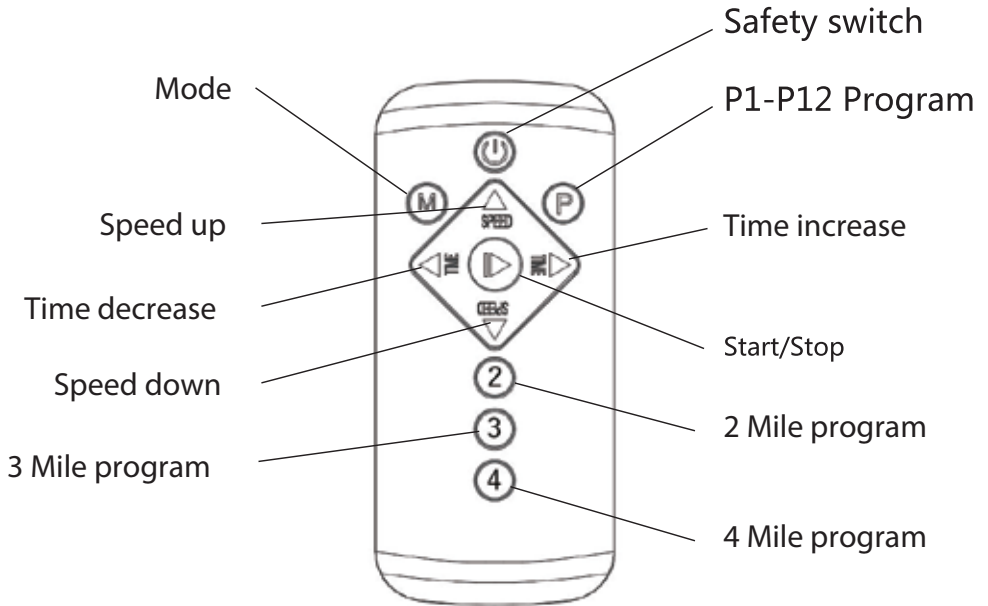

Safety switch: You can press this key to stop the product if any emergency situation happens.

Start/Stop: You can start the product by pressing this key when it is plugged and panel displays 000, also you can stop the product by pressing this key.

Mode: You can switch speed, time and calorie display by pressing this key.

P1-P12 Program: You can switch program P1-P12 by pressing this key.

Time increase: You can increase exercise time by pressing this key, also you can adjust speed, calorie and distance in manual mode.

Time decrease: You can decrease exercise time by pressing this key, also you can adjust speed, calorie and distance in manual mode.

Speed up: You can increase speed by pressing this key, also you can adjust speed, calorie and distance in manual mode.

Speed down: You can decrease speed by pressing this key, also you can adjust speed, calorie and distance in manual mode.

2 Mile program: Press this key the speed will become 2mils/H.

3 Mile program: Press this key the speed will become 3mils/H.

4 Mile program: Press this key the speed will become 4mils/H.

Exercise advices and plan

Warm up: do warm up exercise for 5~10 minutes before using this product

Breath: do not hold your breath when you are using this product, try to breath by nose and coordinate with your movement. You should stop if breath too hasty.

Exercise frequency: muscle should rest for 48 hours after exercising.

Intensity: it depends different individual, please increase intensity gradually, the fatigue can be cure under this situation.

Diet: To protect the digestive system, please do not use this product in 1 hour after meal, also do not take any food in half hour after exercise. Try to not drink water when doing exercise to reduce visceral burden.

Stretching exercises: No matter what speed you will run, a first stretching exercise is necessary, it can improve muscle activity and reduce the risk of sports injured. So you can follow the guidance below after warming up, 5 times for each pose, and do it again after exercise.

1. Stretch down bend down to relax shoulder and back then try to touch your feet, 3 times (picture 1).

2. Stretch legs sit on a mat, stretch one leg and keep the other to stay balance then try to touch your toes of the straight leg, stay the pose for 10~15 seconds then repeat to the other leg, 3 times (picture 2).

3. Stand and put your hands on the wall or table, then push your body down and stay 10~15 seconds, 3 times for each leg (picture 3).

4. Ankle joint stretch stand and hold something to keep balance, then pull one ankle to your Buttocks until you feel tense on leg muscle, stay 10~15 seconds, 3 times for each leg (picture 4).

5. High stretch sit and keep feet against, then pull feet to groin, stay 10~15 seconds and do it for 3 times (picture 5).

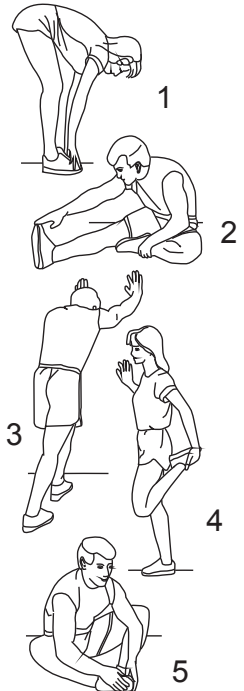

Instruction manual

Brief introduction

- 1.It is a easy operating-panel, it does not require complicated operation
- 2.Vocabulary explanation:
- 3.Treadmill related: speed
- 4.Sports related: distance, calorie, time
- 5.Mode: manual mode and auto mode
- 6.Manual mode: free adjusted mode without default data
- 7.Auto mode: the mode with default data.

Led digital display



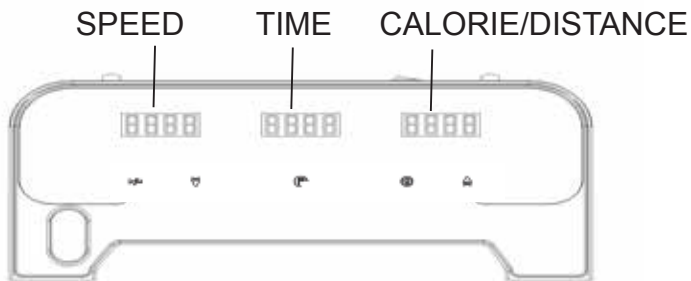

- 1.SPEED
- 2.TIME
- 3.CALORIE/DISTANCE

Keys

Control Panel Instruction



Control Panel Instruction

-  ON/Off
-  Speed -
-  Speed +
-  Program P1-P12
-  Mode H1-H3

Parameter



- 1.Voltage 110V/50/60Hz
- 2.Minimum speed 0.5 Mile/H
- 3.Maximum speed 4Mile/H
- 4.Under auto mode, the minimum exercise time is 5 minutes, the maximum time is 99 minutes.
- 5.Under manual mode the minimum distance is 1 mile, the maximum distance is 99 miles.
- 6.Under Manual mode, the minimum calorie burning is 20 Cal, the Maximum calorie burning is 999 Cal.

Safety warning



This product does not equip emergency safe key, please adjust the appropriate speed. You can stop the product by pressing the red stop key if any unexpected situation happens.



Mode and function instruction



Auto mode:



please check whether the product is plugged before stating your exercise, switch is ready, display will show 000 when the product is standby, press start key there will be a 3 seconds count down and speed display will show 0.5mile/H, distance and time will show in clockwise direction.You can adjust speed by press   , the minimum is 0.5 mile/H and the maximum is 4 Miles/H.

Manual mode :

1. Display will show 0:00 when the product is standby, press P key the display will show P1, then you can switch to p2...p12 by pressing P key, i The time display will show 30minutes and blinks, you can adjust time from the minimum 5 to the maximum 99 by press the   key, you can press the  key after you finish choosing mode and time, product will start working after a 3 seconds count down.

2. Display will show 0:00 when the product is standby, press the M key display will show H-1, the time will blink, the default is 30 minutes, then you can adjust time from the minimum 5 to the maximum 99 by press the   key, you can press the  key after you finish choosing mode and time, product will start working after a 3 seconds count down.

3. Display will show 0:00 when the product is standby, press the M key display will show H-2, the distance will blink, the default is 1 mile, then you can adjust distance from the minimum 1 to the maximum 99 by press the   key, you can press the  key after you finish choosing mode and time, product will start working after a 3 seconds count down.

4. Display will show 0:00 when the product is standby, press the M key display will show H-3, the calorie will blink, the default is 20 KCal, then you can adjust calorie from the minimum 20KCal to the maximum 990KCal by press the   key, you can press the  key after you finish choosing mode and time, product will start working after a 3 seconds count down.

5. The Hot key: You can change the speed to the pre-set speed by press the 2, 3, 4 mile hot key on the remote control.

Maintenance

Lubricating

The running belt must be lubricated with the specialized silicone oil after using for a period.

1.Suggest lubricating frequency : Using time is less than 3 hours a week Lubricate it every 5 month

Using time is 4-7 hours a week Lubricate it every 2 month

Using time is over 7 hours a week Lubricate it every month

It will not be better if it is over lubricating, but reasonable lubricating can be a important factor to increase the life of treadmill

2.How to do the lubricating

To check whether your treadmill needs lubricating, you can hold the running belt and put the other hand to touch the bottom center of the running belt, if you can feel the wet silicone oil that means it does not need lubricating. If you feel the running belt is very dry that means your treadmill need a lubricating.

A. How to lubricating (as picture)

B.Stop and fold the treadmill

C.Raise the running belt on the base, then try to put the silicone oil pot under the running belt and smear the silicone oil on the belt and both side of the treadmill, then set 1KM/H to make sure silicone oil lubricates every well, you can step the running belt from left to right to improve the lubricating effect.

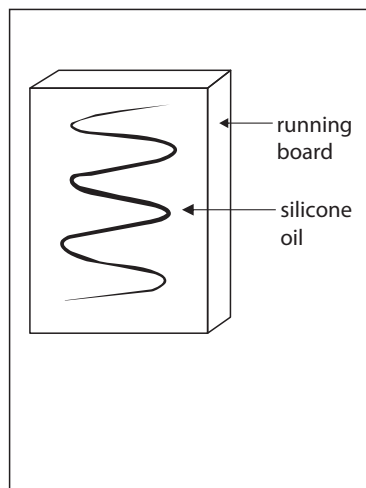
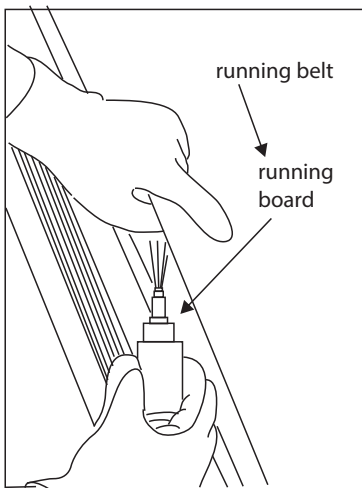

3.Adjusting the elastic tendency of running belt

Every treadmill must set the elastic tendency before it leaves factory and after assembly, but it will become loose after using a period.

Just like it will stuck or slide sometimes, you can turn the adjusting bolt in clockwise direction, semi-circle a time (left and right at the same time) to adjust the running belt. Don't make it too loose or too tight, or the running belt will slide or make motor over load.

4.Running belt deviating.

All running belt is in the right place when it is packaged. But there are some factors will cause this situation.

a).The treadmill is not set flat

b).User does not step on the center of the running belt

c).The situation caused by a or b is easy to be solved, just set the treadmill flat and let it idle for several minutes can solved the problem. If the deviating still exists, you can use the 6mm Allen wrench to adjust it in a quarter turn.

Deviating is not in the warranty scale, user can maintain it following the instructions. But please fix it as soon as you find the problem or it will break the running belt.



If deviating turns to right, then turn the left screw in counter-clockwise direction,turn the right screw in clockwise direction.

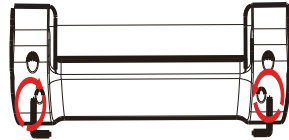

If deviating turns to left, then turn the left screw in clockwise direction, turn the right screw in counterclockwise direction.

- 1.Turn the left screw in clockwise direction with Allen wrench
- 2.Adjust the intensity, when the running belt will not slide during loading is ok.(clean the debris between belt ditch and belt wheels)

Common malfunction and solution

Malfunction	cause	solution
treadmill can not work	unplug	plug the power cord
	emergency device removed	set the emergency stop device back to position
	single wire or power supply broken	check signal wire
	switch off	switch on
running belt dose not move smoothly	not enough lubricating	lubricate with silicone oil
	running belt is too tight	adjust the intensity of the running belt
E 0 2	Motor over-voltage protection	1. Do not use over-voltage power source 2. Change remote-control
E 0 3	Product over-current protection	1.Reduce loading, do not use product on a overloading state. 2.use more silicone oil
E 0 4	Motor malfunction	1. Make motor lines firmer 2.Change motor or remote control
E 0 6	signal error	1.Reconnect signal line 2.change signal line or change control panel.
E 0 7	Safety device fallen	1、 put the safety device back to position 2、 change control panel
E 0 C	Explosion-proof protection	Power transistor breakdown, change remote control

1.Other malfunctions and solutions.

- a:check whether the power plug is inserted correctly and the switch is on, whether the control is fuse blown.
- b:whether the 4-core line of control panel and display is connected correctly.
- c:whether the control and transformer is intact.

2:Heat beat no display or garbled display (if product has this function.)

- a:Check whether the heart beat sensor wire is connected correctly.
- b:Whether your hand contacted the sensor close enough.
- c:wash hands and keep them moist.

3:Motor can not work .

- a:Check all wires and make sure they are connected correctly.
- b:check the code showed on the display.

4:Touch screen is insensitive.

- a:whether the touch screen is moist.
- b:Whether there is sweat on your hands