

kbice

2 in 1 Countertop Ice & Water Dispenser USER INSTRUCTIONS



FDFD10502

SAFETY INSTRUCTIONS	2
FEATURES & SPECIFICATIONS	4
USE OF DISPENSER	6
DISPENSER CARE	7
INSTALLATION INSTRUCTIONS	10
TROUBLESHOOTINGS	12
SERVICE & IMPORTANT NOTICE	14

GENERAL OPERATING INSTRUCTION

Read these instructions before use and save them for future reference.
Let the unit rest and unplugged for 24 hours before use.

- Remove all external and internal packaging materials. Be sure that all parts have been included before discarding any packaging materials. You may want to keep the packaging materials for use at a later date.
- Upon receipt and inspection of the unit, the power cord must be replaced if it is damaged.
- Contact customer service at 800-433-9938 or info@kbgoodice.com

SAFETY INSTRUCTIONS

Electrical Safety

DANGER

Improper use of the power cord plug can result in the risk of electrical shock, property damage and personal injury or death.

- This appliance is equipped with a 3-prong grounding-type plug and shall be plugged into a properly connected grounding-type outlet.
- It is required to use a 3-prong grounding-type electrical outlet properly grounded in accordance with the National Electrical Code and local codes and ordinances.
- A separate adequately fused and grounded circuit shall be used for this appliance. The voltage rating must match the rating label on the unit.
- Do not use an adapter or an extension cord.
- Do not under any circumstances cut or remove the third ground prong from the power cord.
- Never unplug the appliance by pulling the power cord. To disconnect the unit, always grip the plug firmly and pull straight out from the wall outlet.
- Do not operate the appliance if the appliance housing is removed or damaged.
- Do not attempt to repair or replace any part of your appliance unless it is specifically recommended in this manual. All other servicing shall be referred to a qualified technician.
- To protect against electric shock, do not immerse appliance, plug or cord into water or other liquids.

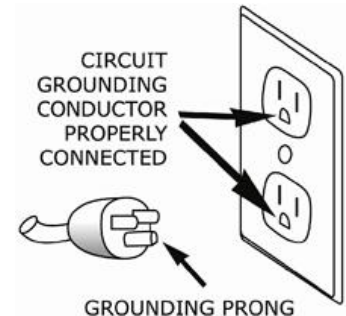

Child Safety

- Exercise caution and use reasonable supervision when appliance is used near children. Never allow children to operate, play with or crawl inside the unit. Keep packing materials away from children.
- Keep fingers out of pinch point areas and be careful when closing doors if children are around.

Cleaning Safety

DANGER

To reduce the risk of injury when cleaning your appliance, follow these basic precautions.

- Unplug the appliance or disconnect power before performing any maintenance or cleaning.
- Do not clean appliance with flammable fluids. Do not store or use gasoline or other flammable vapors or liquids in the vicinity of this or any other unit. The fumes can create a fire hazard or explosion.
- Do not use solvent-based cleaning agents or abrasives on the interior or exterior of the appliance. These cleaners may damage or discolor the appliance.
- Do not operate the appliance with wet hands, while standing on a wet surface or while standing in water.

Moving Safety

DANGER

To reduce the risk of injury when moving your appliance, follow these basic precautions.

- Exercise caution when moving and installing the appliance. The unit is heavy, to prevent strain or injury, it may require two or more people to move the unit.
- Remove all ice, empty water and secure all loose accessories before you transport the unit. Use protective materials to prevent the glass shelves from being damaged.

Disposing Safety

DANGER

When disposing of refrigeration appliances, special handling is often required. It is the consumer's responsibility to comply with federal and local regulations when disposing of this product.

- Keep the carton, plastic bags and any exterior wrapping materials in a safe place where children cannot reach them. If you don't need these materials, destroy or recycle them. These items may cause suffocation to children.
- To avoid entrapment and suffocation, before you discard this appliance, remove the doors and leave the shelves in place, so that children may not climb inside.

FEATURES & SPECIFICATIONS

Overview

This countertop ice and water dispenser features a touch operated automatic ice and water dispensing system. The freezer keeps 9 lbs of crescent ice cold and available anytime. POU filtered water system creates the flexibility to place it anywhere in the office, break room, hotel and home. Stainless or black doors with silver accents give a sleek and modern appearance.

Features and Parts

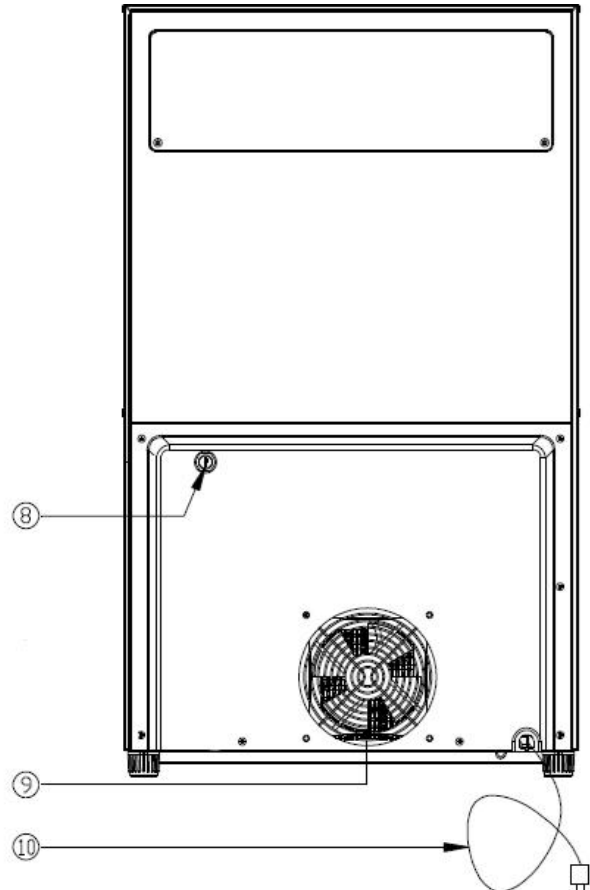
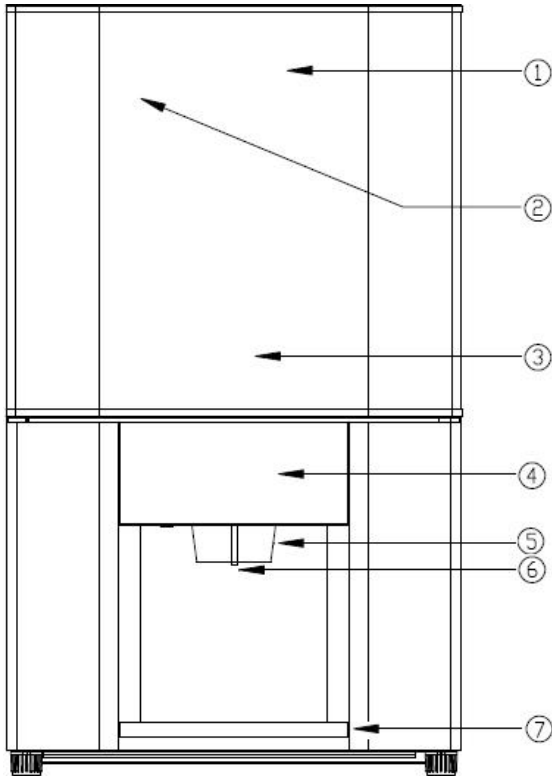

1. Freezer Door
2. Ice maker (located inside)
3. Ice Bin (located inside)
4. Touch Panel
5. Ice Dispenser
6. Water Dispenser
7. Drip Tray
8. Water Line Connector
9. Condenser Fan
10. Power Cord

- This dispenser allows you to enjoy ice and water with the touch of a button.
- The two-evaporator cooling system and ice freezer keep ice from melting and produce ice quicker.
- Hot-gas defrost system makes the unit frost-free and maintenance free.
- POU filtered water supply provides you with clean and great tasting water.
- Touch control brings you the simplicity to select and dispense your preferred ice or water.

Specifications and Dimensions

Model No.	DFD10502
Ice Type	Crescent Cubed
Ice Production Capacity (70°F Air / 50°F Water)	Crescent Ice 11 lb / 24 h
Ice Bin Capacity	9 lb
Defrost Type	Automatic
Water Type	Room Temp Water
Operating Temperature for Ice	50~110 °F
Water Supply	POU Filtered Water
Electrical Rating	115V/60HZ/2.5A
Unit Dimensions	18-1/8"W x 22-3/8"D x 31-1/2"H
Depth w/ Door Open 90 Degree	39-3/8"
Net Weight	90 lb

USE OF DISPENSER

CAUTION	Do not store food and drink in the ice freezer.
NOTE	For the first time use, allow 24 hours to produce the first batch of ice. Discard the first three batches of ice produced.
NOTE	For the first time use or after connecting a filtered water source or after replacing the water filters, flush the water system by dispensing several cups of water, then discarding them. Repeat this until water is clear and tasting good.

Touch Panel Functions



Dispensing ice

NOTE	Ice does not dispense while the freezer door is open. If ice cubes haven't been used for days, they may freeze together and unable to dispense. If this happens, pull out the ice bin and shake it, then push it in.
-------------	---



Ice dispensing button

- Place a cup under the ice dispenser.
- Press and hold the “Ice” button to dispense ice.

Dispensing water



Water dispensing button

- Place a cup under the water dispenser.
- Press and hold the “Water” button to dispense water.

DISPENSER CARE

DANGER	Unplug the unit or disconnect power before performing any maintenance.
CAUTION	If ice cubes block the feeler arm, clear the ice cubes before you pull out the ice bin. Move the feeler arm up and keep it above the ice bin while you pull out the ice bin. Otherwise the feeler arm may be damaged if it is obstructed by the ice bin.

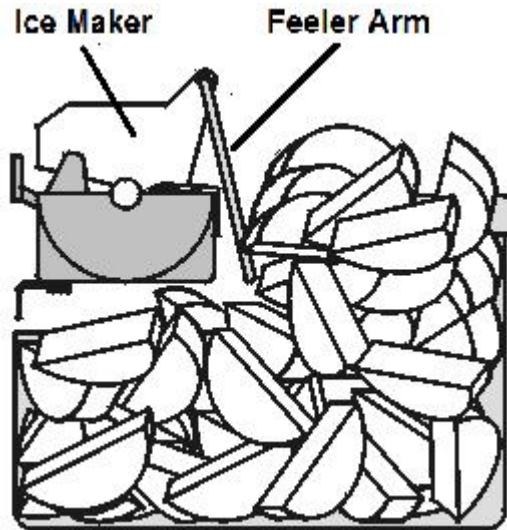

How to empty ice bin

- Use the instructions below to remove the ice bin when emptying ice or cleaning the ice bin.

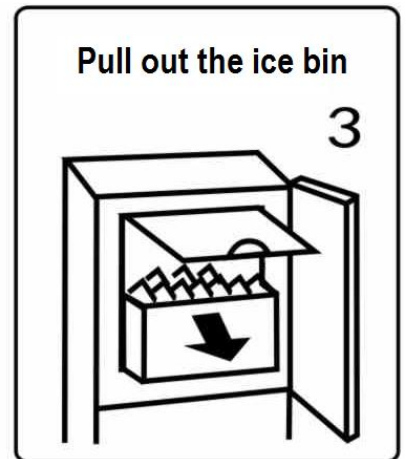
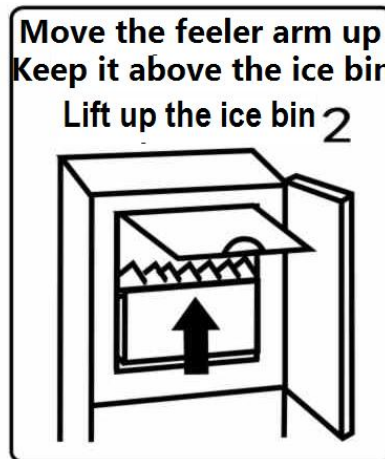
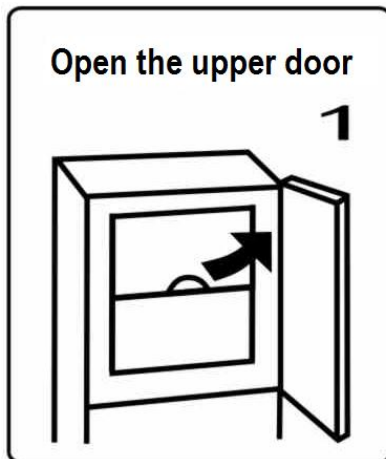

- Push the ice bin back until the auger is engaged in the auger coupler. If it is stuck, rotate the auger 1/8 turn, then push it in again.

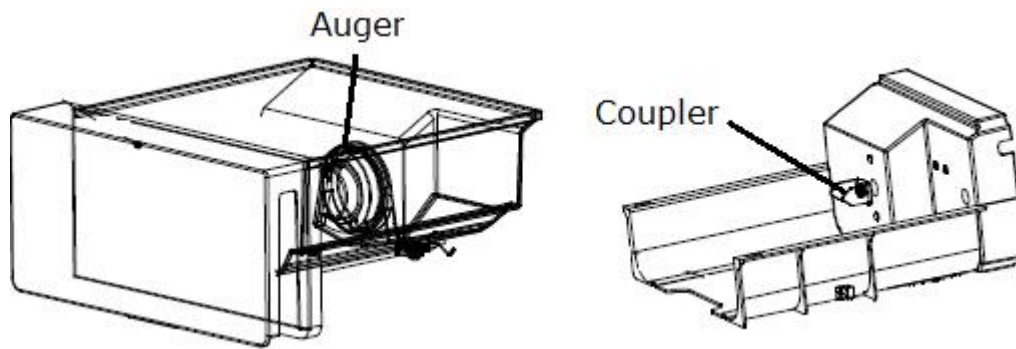

How to remove condensate

- The unit is operated with automatic defrost cycle. The water collects in a condensate drip tray that is located at the compressor compartment. Normally, the water evaporates through the hot gas tubing.
- In very high humidity conditions, manually empty water if the tray is full.

If heavy frost builds up in the freezer

- Press and hold the “Ice” and “Water” buttons at the same time for more than 10 seconds until you will hear a long beep when the defrost cycle starts.

If ice cubes are frozen together

- Press the “Ice” button to dispense ice for a few minutes.
- Open the upper door and pull out the ice bin to shake it or remove the large clumps of ice cubes.

If the ice bin is stuck

- Unplug the unit.
- Use a hair dryer with warm or cold air to melt the ice.
- Pull out the ice bin and empty it.
- Wipe up water and put the ice bin back.
- Plug in the unit.

If ice cubes are jammed in the ice maker

- Unplug the unit.
- Use a hair dryer with warm or cold air to melt the jammed ice cubes.
- Then remove the jammed ice cubes.
- Plug in the unit.

If a power outage happens

- Unplug the unit.
- Pull out the ice bin and empty it.
- Wipe up water and put the ice bin back.

If you are away on holidays or vacations

- Unplug the unit or disconnect the power.
- Open the upper door
- Pull out the ice bin and empty it.
- Let the freezer defrost.
- Wipe up water and dry the freezer.
- Release the remaining water.

What normal operating sounds you may hear

- You may hear a boiling, rattling or gurgling sound produced by flow of refrigerant through the evaporator.
- You may hear air being forced through the unit by the evaporator fan.
- You may hear air being forced through the condenser by the condenser fan.
- You may hear a clicking sound produced by the refrigerant valve or dispensing valve.
- You may hear a water dripping sound during automatic defrost cycle.
- You may hear a high pitched hum or pulsating sound produced by the compressor.
- You may hear the ice cubes being ejected from the ice maker to the ice bin.

INSTALLATION INSTRUCTIONS

Location

CAUTION	This unit is designed for indoor use only.
----------------	---

- Place the unit away from direct sunlight and heat sources.
- Do not install the unit in moist areas.
- Do not install the unit in garage.
- Do not install the unit where the ambient temperature range will be below 50 °F or above 110 °F. Otherwise, the compressor will not be able to maintain proper temperature.
- The unit must be placed in a properly ventilated location to prevent heat build-up generated by the refrigeration system. Failure to do so will prevent the unit from cooling properly, and may result in damage to unit components as well as its contents.
- The unit must be installed on a counter that is level and strong enough to support a fully loaded unit up to 100 lb.

Clearance

CAUTION	This unit is designed for free-standing or recessed installation.
----------------	--

- Allow for minimum 2" on the back, and 1" at the top for proper air circulation.
- If the unit is installed next to a fixed wall on the right side, leave 1" minimum clearance to allow the door to swing.
- Adjust the levelling legs to level the unit at a height that allows the door to be opened and closed properly.

Electrical Requirements

DANGER	It is required that you connect this unit only to a GFCI protected receptacle. It is strongly recommended that you do not use an adapter or an extension cord to connect this unit because of potential safety hazards.
---------------	--

- A dedicated 120V, 60Hz, 15A fused, grounded electrical supply is required. It is recommended that a separate circuit serving only your appliance be provided.
- Only connect to properly polarized outlets.
- Use outlets that cannot be turned off by a switch.
- Only plug the unit into a grounded 3 prong outlet.

How to insert or disconnect a tube or plug

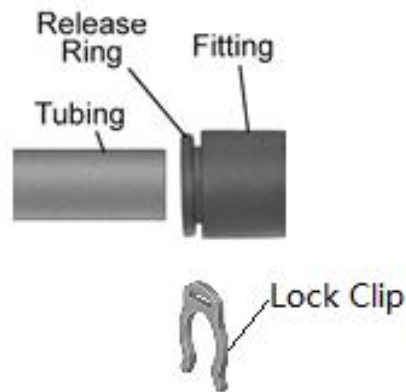

1. Remove the lock clip first.
2. To install, insert a tube or plug until it is engaged;
To disconnect, press the release ring down and pull out a tube or plug.
3. Install the lock clip.

Water filtration system installation

NOTE	A municipal water supply or other potable water with water pressure between 20 and 120 psig is required to operate this unit. Drain is not required.
-------------	---

- Remove the plug of the filtered water line connector (8), which is located at the back of the unit. Insert the free end of the filtered water line into the connector (8) until it stops.

TROUBLESHOOTINGS

Complaint	Possible Causes	Response
Unit is not working and display is not lit	<ul style="list-style-type: none"> a. Power cord is unplugged. b. No power at outlet. c. Power cord is broken. d. Control PCB is defective or with wiring problems. e. Display PCB is defective or with wiring problems. 	<ul style="list-style-type: none"> a. Plug in the power cord. b. Check for outlet and breaker or fuse. c. Call for service. d. Call for service. e. Call for service.
Icemaker is not producing ice	<ul style="list-style-type: none"> a. There is ice in the ice mold, but ice cubes are jammed. b. The ice mold is empty and the water fill tube freezes. c. The ice mold is empty and the water filters are clogged. d. The ice mold is empty and the ice maker water valve is defective or with wiring problems. e. The ice mold is empty and the ice maker is defective. f. The ice mold is empty and the cooling system is defective. g. There is ice in the ice mold, but the ice maker is not turning. h. There is water in the ice mold but the cooling system is not working. 	<ul style="list-style-type: none"> a. Clear the ice cubes. b. Unplug the unit and remove the ice bin then wait until fill tube is clear. c. Bypass the water filters and check if ice quality improves. d. Call for service. e. Call for service. f. Call for service. g. Call for service. h. Call for service.
Icemaker is not producing enough ice or ice cubes are small	<ul style="list-style-type: none"> a. The freezer door is not closed properly. b. The ice chute flap is not closed properly c. The ice maker water valve is not working properly. d. The ice maker is not working properly. e. The cooling system is not working properly. 	<ul style="list-style-type: none"> a. Check for the door seal and door opening. b. Check for the flap. c. Call for services. d. Call for service. e. Call for service.
Ice cubes are hollow	<ul style="list-style-type: none"> a. The ice maker thermostat is defective. b. The ice maker water valve is defective. c. The cooling system is not working properly. 	<ul style="list-style-type: none"> a. Call for service. b. Call for service. c. Call for service.
Ice cubes are frozen together in the ice bin	<ul style="list-style-type: none"> a. If ice cubes haven't been used for a long period of time, they may freeze together. b. Ice cubes are produced continuously because the feeler arm is blocked up. c. The freezer door is not closed properly. d. The icemaker is not working 	<ul style="list-style-type: none"> a. Pull out the ice bin and shake it or remove the large clumps of ice cubes. b. Clear ice cubes around the feeler arm. c. Check for the door seal or door opening. d. Call for service.

	properly. e. The cooling system is not working properly.	e. Call for service.
Ice does not dispense	a. There are not enough ice cubes in the ice bin. b. Ice cubes are frozen together in the ice bin. c. The freezer door is open. d. The freezer door magnetic switch is defective. e. The auger motor is broken. f. The flap motor is broken or with wiring problems. g. Control PCB is defective or with wiring problems. h. Display PCB is defective or with wiring problems.	a. See Ice maker is not producing ice or Ice maker is not producing enough ice or ice cubes are small. b. Pull out the ice bin and shake it or remove the large clumps of ice cubes. c. Close it. d. Replace it. e. Call for service. f. Call for service. g. Call for service. h. Call for service.
Water does not dispense	a. The dispensing valve water tubes are broken. b. The water dispensing valve is defective. c. Control PCB is defective or with wiring problems. d. Display PCB is defective or with wiring problems.	a. Call service. b. Call service. c. Call service. d. Call service.
Water dispenser is slow	a. The water dispensing tubes are kinked. b. The water dispensing valve is defective.	a. Straighten them. b. Call service.
Water is leaking	a. The dispenser drip tray is full. b. The condensate drip tray is full. c. The internal water reservoir or tubes are leaking. d. The water level sensor of the internal water reservoir is defective. e. The water dispensing valve is defective. f. Ice is being melted because of high freezer temperature.	a. Empty it. b. Empty it. c. .Call for service. d. Call for service. e. Call for service. f. Check for power or call for service.
Icemaker evaporator is iced	a. The freezer door is not closed properly. b. The ice chute flap is not closed properly. c. Water fill tube is leaking water.	a. Close it. b. Close it. c. Align the fill tube in the fill cup.
Both freezer and icemaker evaporators are iced	a. The defrost solenoid valve is defective or with wiring problems. b. The defrost drip tray heater is broken or with wiring problems. c. The evaporator fan is broken. d. The defrost sensor is defective. e. The freezer sensor is defective.	a. Call for service. b. Call for service. c. Call for service. d. Call for service. e. Call for service.

SERVICE & IMPORTANT NOTICE

The manufacturer has a policy of continuous improvement on its products and reserves the right to change materials and specifications without notice.

Contact us with any questions at 800-433-9938 or info@kbgoodice.com

Or visit 24412 Main St. Suite 105 Carson, CA 90745 and www.floridaappliances.com

LIMITED WARRANTY: Seller warrants that the goods will be free of defects in materials and workmanship for a period of 12 (twelve) months from date of sale, removal and re-installation of unit is not included in warranted labour. For a scratch and dent or refurbished unit, warranty is 3 months from your dated invoice (parts for function only, not cosmetic). There is no warranty on parts purchased separately. Purchaser's exclusive remedy is limited, at Seller's option; to repair or replace defective part[s] with either new or factory reconditioned part[s]. Purchaser is responsible for shipping the unit pre-paid to designated facility and Seller will pay return shipping charges in the continental United States for items repaired under warranty within 12 (twelve) months from date of sale. Improper placement of the unit will void the warranty. This limited warranty does not cover damage due to such things as accident, misuse, abuse, mishandling, neglect, acts of God, fires, earthquakes, floods, high winds, government, war, riot or labour trouble, strikes, lockouts, delay of carrier, unauthorized repair, or any other cause beyond the control of the Seller, whether similar or dissimilar to the foregoing. Seller is not responsible for any damages caused to Seller's property resulting from the good. This limited warranty applies only inside the Continental US. (Alaska, Puerto Rico and Hawaii are not warranted.)

Seller is not responsible for incidental or consequential damages, and there are no warranties, expressed or implied, which extend beyond the Limited Warranty described above. The implied warranties of merchantability and of fitness for a particular purpose are hereby expressly disclaimed. Some states do not allow the exclusion of incidental or consequential damages, or a waiver of the implied warranties of fitness and/or merchantability, so the above limitations may not apply to you. This warranty gives you specific legal rights and you may also have other rights which vary from state to state. In the event of any dispute between Seller and Purchaser arising out of or relating to these terms and conditions or to the goods sold generally, Purchaser must first file a written claim with Seller within ten days of the occurrence giving rise to the claim and wait an additional thirty days for a response before initiating any legal action. The sale and all terms are subject to Nevada law. Any legal proceeding arising out of or relating to these terms and conditions or to the goods sold generally shall be brought solely and exclusively in the City of Las Vegas. In no event may Purchaser initiate any legal proceeding more than six months after the occurrence of the event giving rise to the dispute.

The above terms and conditions are the only ones governing this transaction and Seller makes no oral representations of any kind. These Terms and Conditions can only be modified in writing, signed by both Purchaser and Seller.

KBICE is a registered trademark of Florida Appliances Inc. All products, features, and services are subject to change without notice. We cannot guarantee the accuracy of the contents of this document. We disclaim liability for errors, omissions, or future changes.
Copyright©2020 Florida Appliances Inc. All rights reserved.