

Oster

User's Manual

1.1 Cu. Ft. Countertop Microwave



Model: OGZD1102

TABLE OF CONTENTS

IMPORTANT SAFETY INSTRUCTIONS	2-3
PRECAUTIONS TO AVOID POSSIBLE EXPOSURE TO EXCESSIVE MICROWAVE ENERGY	3
INSTALLATION GUIDE	4
GROUNDING INSTRUCTIONS	4-5
PRODUCT DIAGRAM	5
CONTROL PANEL	6
INSTALLING THE TURNTABLE	6
OPERATION INSTRUCTIONS	7-11
COOKING UTENSILS GUIDE	12
COOKING TECHNIQUES	13
CLEANING AND CARE	14
BEFORE CALLING FOR SERVICE	14
SPECIFICATIONS	15

IMPORTANT SAFETY INSTRUCTIONS

READ ALL SAFETY INSTRUCTIONS BEFORE USING THIS MICROWAVE

WARNING - to reduce the risk of burns, electric shock, fire, injury to persons, or exposure to excessive microwave energy, basic safety precautions should be followed, including the following:

1. Read all instructions before using the microwave.
2. Read and follow the specific "PRECAUTIONS TO AVOID POSSIBLE EXPOSURE OR EXCESSIVE MICROWAVE ENERGY" on page 3.
3. This microwave must be grounded. Connect only to properly grounded outlets. See page 4 for grounding instructions.
4. Install or place this microwave only in accordance with installation instructions.
5. Some produce such as whole eggs and sealed containers - for example, closed glass jars - are able to explode and should not be heated in this oven.
6. This microwave is intended for use only as described in this manual. Do not use corrosive chemicals or vapors in this microwave. This type of microwave is specifically designed to heat, cook, or dry foods. It is not designed for laboratory use.
7. As with any appliance, close supervision is necessary when used by children.
8. To reduce the risk of fire in the oven cavity, do not overcook food. Carefully attend to the microwave when paper, plastic, or other combustible materials are placed inside the microwave to facilitate cooking.
9. Remove wire twist-ties from paper or plastic bags before placing in microwave.
10. If materials inside the microwave should ignite, keep microwave door closed, turn it off, and disconnect the power cord or turn off the power fuse at the circuit breaker panel. Do not use the microwave cavity for storage purposes.
11. Do not leave paper products, cooking utensils, or food in the cavity when not in use.
12. Liquids, such as water, coffee, or tea, may overheat beyond the boiling point without appearing to be boiling due to surface tension of the liquid. Visible bubbling or boiling when the container is removed from the microwave is not always present. THIS COULD RESULT IN VERY HOT LIQUIDS SUDDENLY BOILING OVER WHEN A SPOON OR OTHER UTENSIL IS INSERTED INTO THE LIQUID. To reduce the risk of injury: do not overheat the liquid; stir the liquid both before and halfway through heating; do not use straight-sided containers with narrow necks; after heating, allow the container to stand in the microwave a short time before removing; use extreme care when inserting a spoon or other utensil into the container.
13. Do not heat oil or fat for deep-frying in this microwave. It is difficult to control the temperature of oil in the microwave.
14. Pierce foods with heavy skins, such as potatoes, before cooking.
15. The contents of feeding bottles and baby jars should be stirred or shaken and the temperature should be checked before serving to avoid burns.
16. Cooking utensils may become hot from heat transferred from the heated food. Pot holders may be needed to handle these utensils.
17. Do not cover or block any openings on the microwave.
18. Do not store or use this microwave outdoors. Do not use this microwave near water, for example, near a kitchen sink, in a wet basement, near a swimming pool, or similar location.
19. Do not operate this microwave if it has a damaged cord or plug, if it is not working properly, or if it has been damaged or dropped.

SAVE THESE INSTRUCTIONS

IMPORTANT SAFETY INSTRUCTIONS (continued)

20. Do not immerse the cord or plug in water. Keep cord away from heated surfaces. Do not let the cord hang over the edge of the table or counter.
21. Use only thermometers specifically designed for microwaves.
22. Do not operate any heating or cooking under this microwave.
23. Be certain the glass tray and roller rings are in place when using the microwave.
24. Read and follow the specific "Precautions to Avoid Possible Exposure to Excessive Microwave Energy" section found below.
25. When cleaning microwave surface and door, use only mild, nonabrasive soaps or detergents applied with a sponge or soft cloth.
26. This microwave should be serviced only by qualified service personnel. For service and repair, please contact our Customer Support Center at 1-800-324-0340.

PRECAUTIONS TO AVOID POSSIBLE EXPOSURE TO EXCESSIVE MICROWAVE ENERGY

1. Do not attempt to operate this microwave with the door open. Door open operation can result in harmful exposure to microwave energy. It is important not to defeat or tamper with the door interlocks.
2. Do not place any objects between the microwave front face and the door, or allow soil or cleaner residue to accumulate on sealing surfaces.
3. Do not operate the microwave if damaged. It is particularly important that the microwave door be properly closed and there is no damage to the door (bent), hinges and latches (broken or loosened), or door seals and sealing surfaces.
4. The microwave should not be adjusted or repaired by anyone except properly qualified service personnel.

SAVE THESE INSTRUCTIONS

INSTALLATION GUIDE

1. Make sure all packing materials are removed from inside the microwave door.
2. Check the microwave for damage, such as misaligned or bent door, damaged door seals and sealing surface, broken or loose door hinges and latches, and dents inside the cavity or on the door. If there are any damages, do not operate the microwave and contact Customer Service at 1-800-324-0340.
3. This microwave must be placed on a flat, stable surface to hold its weight and the heaviest food likely to be cooked inside.
4. Do not place the oven where heat, moisture, or high humidity is generated. Do not place microwave near combustible materials.
5. For correct operation, the oven must have sufficient air flow. Allow 8" of space above the microwave, 4" at the back, and 2" on each side of the unit.
6. Do not cover or block any openings on the microwave. Do not remove microwave feet. Do not operate the oven without the glass tray, roller support, and shaft in their proper positions. Make sure the power supply cord is undamaged and does not run under the microwave or over any hot or sharp surface.
7. The socket must be readily accessible so the microwave can be easily unplugged in an emergency.

GROUNDING INSTRUCTIONS

This microwave must be grounded. In the event of an electrical short circuit, grounding reduces risk of electric shock by providing an escape wire for the electric current. Consult a qualified electrician or serviceman if the grounding instructions are not completely understood, or if doubt exists as to whether the appliance is properly grounded. For questions regarding the grounding instructions, please contact our Customer Support Center at 1-800-324-0340. If it is necessary to use an extension cord, use only a 3-wire extension cord that has a 3-blade grounded plug, and 3-slot receptacle that will accept the plug on the appliance. The marked rating of the extension cord shall be equal to or greater than the electrical rating of the appliance. Do not use an extension cord. If the power supply cord is too short, have a qualified electrician or service man install an outlet near the appliance.

WARNING: Improper use of the grounding plug can result in risk of electric shock.

ELECTRICAL REQUIREMENTS

- The electrical requirements for this microwave are a 120V, 60Hz, AC only, 20 amp.
- It is recommended that a separate circuit serving only the microwave be provided.
- The microwave is equipped with a 3-prong grounding plug. It must be plugged into a wall outlet properly installed and grounded.

GROUNDING INSTRUCTIONS (continued)

POWER CORD

- A short power supply cord is provided to reduce the risks resulting from becoming entangled in or tripping over a long cord.
- Longer cord sets or extension cords are available and may be used if care is taken in using them.
- If using a longer cord, the marked electrical rating of the cord set or extension cord should be at least as great as the electrical marking of the microwave itself and the extension cord must be a grounded-type 3-wire cord. The longer cord should be arranged so it will not drape over the counter or tabletop.

RADIO OR TV INTERFERENCE

- Should there be any interference caused by the microwave oven to your radio or TV, check that the microwave oven is on a different circuit, relocate the radio or TV as far away from the oven as feasible, and check position and signal of receiving antenna.

PRODUCT DIAGRAM

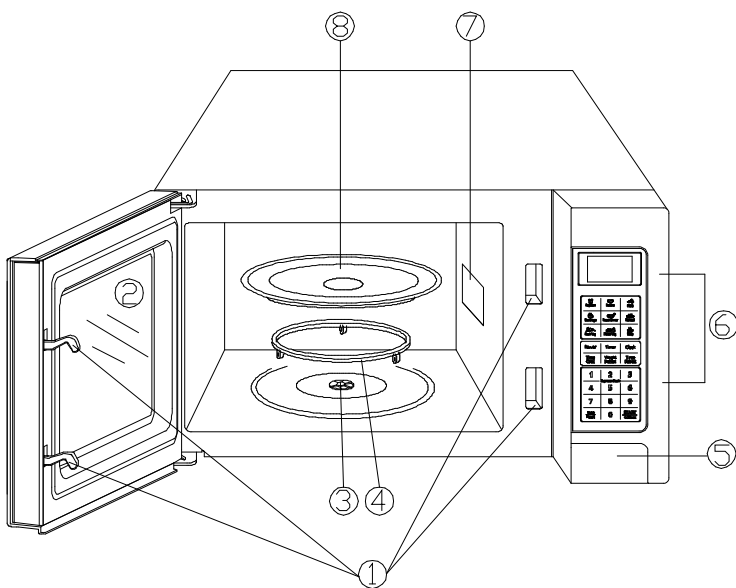

1. Door Lock System
2. Oven Window
3. Shaft
4. Roller Ring
5. Door Release Button
6. Control Panel
7. Spatter Shield (Do not remove)
8. Glass Tray

CONTROL PANEL

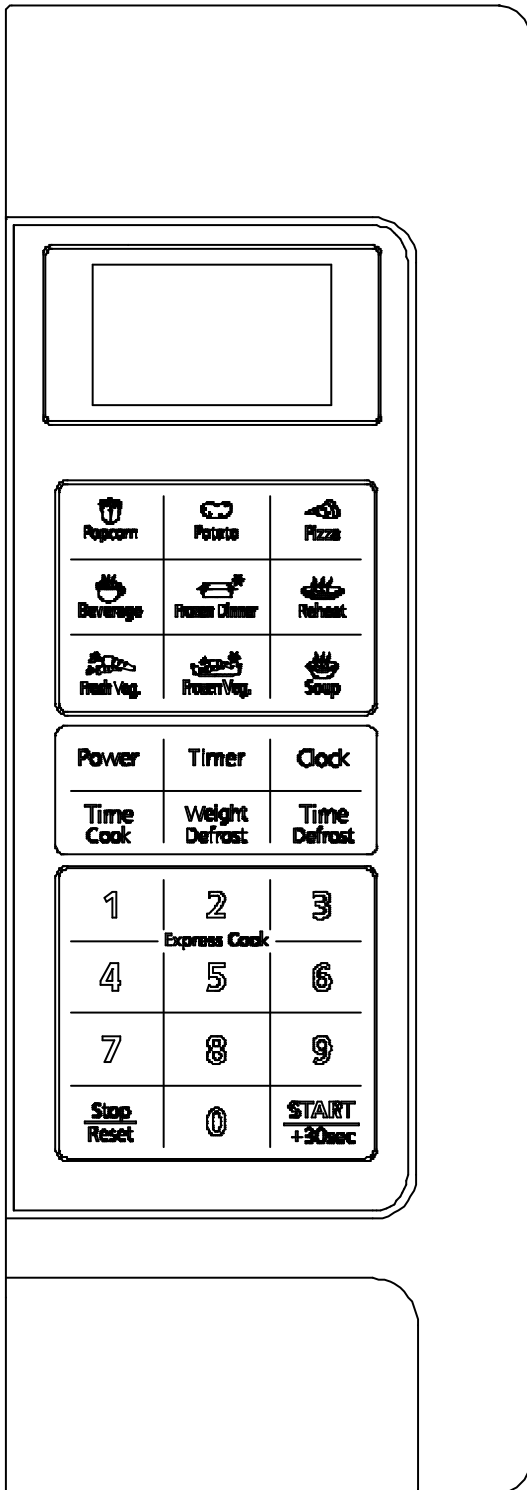

- **DISPLAY**

Cooking time, power, indicators and present time are displayed.

- **QUICK COOK BUTTONS**

Instant settings to cook popular foods.

- **POWER**

Use to set power levels other than high.

- **TIMER**

Timer functions independently, even while a cooking program is in process.

- **CLOCK**

Set current time.

- **TIME COOK**

Use for multi-stage cooking. Enable cooking at multiple power and time settings automatically.

- **WEIGHT DEFROST**

Programmed defrosting based on the weight of the foods to be defrosted.

- **TIME DEFROST**

Quick defrost function that alternates defrost and stand times to quickly and effectively defrost foods.

- **NUMBER PADS (0-9)**

Touch to set time or amount.

- **STOP/RESET**

Clear all previous settings.

- **START/+30SEC**

Touch to start cooking or to set cooking time to add 30 seconds each at full power level.

INSTALLING THE TURNTABLE

- Never place the glass tray upside down.
- The glass tray should never be restricted.
- Both the glass tray and turntable ring assembly must always be used during cooking.
- All food and containers of food should always be placed on the glass tray for cooking.
- If the glass tray or turntable ring assembly cracks or breaks, contact 1-800-324-0340.

OPERATION INSTRUCTIONS

SETTING THE CLOCK

1. Touch CLOCK pad.
2. Use the number pads to enter the correct time. You must touch at least three numbers to set the clock (one for hour and two for minutes).
3. Touch CLOCK pad again.

NOTE:

- This is a 12-hour clock. When the oven is first plugged in or when power resumes after a power interruption, the display will show ENTER CLOCK TIME. If you prefer to not have the clock displayed, touch STOP/RESET.
- You can check the clock time while cooking is in progress by touching the CLOCK pad.

SETTING THE TIMER

1. Touch TIMER.
2. Enter the amount of time by touching the number pads. Digit time is in minutes and seconds and set left to right. Set one digit (a 5 for 5 seconds) or up to four digits (2405 for 24 minutes, 5 seconds).
3. Touch START/+30SEC.

NOTE:

- Time countdown can be seen in display before clock or cooking time is returned to display.
- Touch TIMER and then touch STOP/RESET to cancel TIMER during timing process.

EXPRESS COOK

Program can be started immediately after touching the number pad from 1-6.

Suppose you want to set the quick cooking in 6 minutes.

1. Touch number pad 6.
2. 6:00 can be seen on display.
3. The program starts automatically.

Touch number pad	Time Minutes
1	1 Minute
2	2 Minutes
3	3 Minutes
4	4 Minutes
5	5 Minutes
6	6 Minutes

OPERATION INSTRUCTIONS (continued)

SETTING A COOKING PROGRAM

A. One-stage Cooking

1. Touch POWER pad to enter the power level.
2. Use the number pads to set a cooking time. You can set a cooking time from one second to 99 minutes and 99 seconds.
3. Touch START/+30SEC to start cooking.

Touch POWER pad	Cooking power
Once	100%
Twice	90%
3 times	80%
4 times	70%
5 times	60%
6 times	50%
7 times	40%
8 times	30%
9 times	20%
10 times	10%

B. Two-stage Cooking

Some recipes require different stages of cooking at different temperatures.

1. SET STAGE 1:

Follow steps 1 and 2 in "One-stage Cooking". DO NOT TOUCH START/+30SEC.

2. SET STAGE 2:

Touch COOK then enter proper cooking time and (lower) power level. Most 2-stage recipes use lower power for second stage.

3. Touch START/+30SEC.

NOTE:

·After total time has elapsed, signals sound and END appears in display. Touch any pad or open oven door to clear END before starting another cooking function.

TIME DEFROST

The longest defrosting time is 99 minutes, 99 seconds.

1. Touch TIME DEFROST.
2. Enter desired defrosting time by touching correct number pads. Digital timer sets minutes and seconds from left to right so a single digit can be set (5 for 5 seconds) or up to 4 digits (2405 for 24 minutes 5 seconds).
3. Touch START/+30SEC.

NOTE:

·After time has elapsed signals sound and END appears in display. Touch any pad or open door to clear END before

OPERATION INSTRUCTIONS (continued)

starting another cooking function.

- After setting Time Defrost, oven can be programmed to automatically switch to one or two-stage cooking.
- For Time Defrost and one-stage cooking, follow steps above. Before touching START/+30SEC, touch COOK, enter time and power level. Then touch START/+30SEC.
- For Time Defrost and two-stage cooking, follow steps above. Before touching START/+30SEC, enter two-stage cooking programs.
- During defrosting process, the oven will sound and pause to remind you to turn over the food and then press START/+30SEC to resume.

WEIGHT DEFROST

1. Touch WEIGHT DEFROST pad.
2. Touch the number pad to enter weight.
3. Touch START/+30SEC pad.

NOTE:

- Weight must be in pounds and ounces. Ounce weights less than 10 must be preceded by a 0. If label gives weight in pounds only, change the fraction of a pound to ounces using the chart given above. The maximum weight is 5lbs.16oz.
- Turn over food when oven signals twice. Touch START/+30SEC pad to resume defrosting.
- After total defrosting time, signals sound and END appears in display. Touch any pad or open oven door to clear END before starting another cooking function.

SETTING DOOR LOCK

The door lock prevents unsupervised operation by children.

To set, in standby mode, press and hold STOP/RESET for 3 seconds. LOCK is indicated on the display.

To cancel, press and hold STOP/RESET for 3 seconds. LOCK indication disappears.

POPCORN

1. Touch POPCORN.
2. CODE and cooking time appears in the display. POPCORN automatically sets the cooking time for a 3.5 oz. bag of microwave popcorn.
3. Touch START/+30SEC.

NOTE:

- To change the preset POPCORN time: Touch POPCORN twice. ENTER TIME appears in display. Touch number pads to enter minutes and seconds. Touch START/+30SEC. The longest cooking time is 99 minutes, 99 seconds. This new cooking time will remain whenever you use the POPCORN setting.

OPERATION INSTRUCTIONS (continued)

POTATO

For small potatoes (4-6 oz./each):

1. Touch POTATO once.
2. Enter number of potatoes by touching number pads from 1 to 4.
3. Touch START/+30SEC.

For larger potatoes (8-10 oz./each):

1. Touch POTATO twice.
2. Enter number of potatoes by touching number pads from 1 to 4.
3. Touch START/+30SEC.

PIZZA

Reheating a slice of pizza:

1. Touch PIZZA once. CODE and cooking time appears.
2. Touch START/+30SEC.

Heating a whole frozen pizza:

1. Touch PIZZA twice. CODE and cooking time appears.
2. Touch START/+30SEC.

BEVERAGE

For cups (5-7 oz./each):

1. Touch BEVERAGE once.
2. Enter number of cups by touching number pads from 1 to 4.
3. Touch START/+30SEC.

For larger cups (9-11 oz./each):

1. Touch BEVERAGE twice.
2. Enter number of mugs by touching number pads from 1 to 4.
3. Touch START/+30SEC.

FROZEN DINNER

For one or two small frozen dinners (7-9 oz./each):

1. Touch FROZEN DINNER once.
2. For 1 entree, touch the number pad "1". For 2 entrees, touch the number pad "2".
3. Touch START/+30SEC pad.

For one or two larger frozen dinners (10-12/oz./each):

1. Touch FROZEN DINNER twice.
2. For 1 entree, touch the number pad "1". For 2 entrees, touch the number pad "2".
3. Touch START/+30SEC.

REHEAT

1. Press the REHEAT button.
2. Press START/+30SEC to start.

FRESH VEGETABLE

For fresh vegetables (4-9 oz./serving):

1. Touch FRESH VEG. once.
2. Enter number of servings by touching number pads from 1 to 6.
3. Touch START/+30SEC.

FROZEN VEGETABLE

For frozen vegetables (4-9 oz./serving):

1. Touch FROZEN VEG. once.
2. Enter number of servings by touching number pads from 1 to 6.
3. Touch START/+30SEC.

SOUP

To prepare soup (7-9 oz./serving):

1. Touch SOUP once.
2. Enter number of servings by touching number pads from 1 to 4.
3. Touch START/+30SEC.

This section lists which utensils can be used in this microwave, which have limited use for short periods, and which should not be used in this microwave.

RECOMMENDED

Microwave browning dish -- Use to brown the exterior of small items such as steaks, chops, or pancakes. Follow the directions provided with your browning dish.

Microwaveable plastic wrap -- Use to retain steam. Leave a small opening for some steam to escape and avoid placing it directly on the food.

Paper towels and napkins -- Use for short-term heating and covering; these absorb excess moisture and prevent splattering. Do not use recycled paper towels which may contain metal and could ignite.

Glass and glass-ceramic bowls and dishes -- Use for heating and cooking.

Paper plates and cups -- Use for short-term heating at low temperatures. Do not use recycled paper which may contain metal and could ignite.

Wax paper -- Use as a cover to prevent splattering.

Thermometers -- Use only those labeled "Microwave Safe" and follow all directions. Check the food in several places. Conventional thermometers may be used on microwaved food once the food has been removed from the microwave.

LIMITED USE

Aluminum foil -- Use narrow strips of foil to prevent overcooking exposed areas. Using too much foil can damage your microwave, so be careful. Keep 1" between foil and microwave cavity.

Ceramic, porcelain, and stoneware -- Use these if they are labeled "Microwave Safe". If they are not labeled, test them to make sure they can be used safely.

Plastic -- Only use if labeled "Microwave Safe". Other plastics may melt.

NOT RECOMMENDED

Glass jars and bottles -- Regular glass is too thin to be used in a microwave. It can shatter and cause damage and injury.

Paper bags -- These are a fire hazard, except for popcorn bags that are designed for microwave use.

Styrofoam plates and cups -- These can melt and leave unhealthy residue on food.

Plastic storage and food containers -- Containers such as margarine tubs can melt in the microwave.

Metal utensils -- These can damage your microwave. Remove all metal before cooking.

Note:

- Should you wish to check if a dish is safe for microwaving, place the empty dish in the microwave and microwave on high for 30 seconds. A dish that becomes very hot should not be used.

Your microwave makes cooking easier than conventional cooking, provided you keep these considerations in mind:

STIRRING

- Stir foods such as casseroles and vegetables while cooking to distribute heat evenly.
- Food at the outside of the dish absorbs more energy and heats quicker, so stir from the outside to the center.
- The microwave will turn off when you open the door to stir your food.

ARRANGEMENT

- Arrange evenly shaped foods, such as chicken pieces or chops, with the thicker, meatier parts towards the outside of the turntable where they receive more microwave energy.
- To prevent overcooking, place delicate areas, such as asparagus tips, towards the center of the turntable.

SHIELDING

- Shield food with narrow strips of aluminum foil to prevent overcooking.
- Areas that need shielding include poultry wing tips, the ends of poultry legs, and corners of square baking dishes.
- Use only small amounts of aluminum foil, as larger amounts may damage your microwave.

TURNING

- Turn foods over midway through cooking to expose all parts to microwave energy.
- This is especially important when cooking large foods such as roasts.

STANDING

- Foods cooked in a microwave build up internal heat and continue to cook for a few minutes after heating stops.
- Let foods stand to complete cooking, especially for foods such as cakes and whole vegetables.
- Roasts need this time to complete cooking in the center without overcooking the outer areas.
- All liquids, such as soup or hot chocolate, should be shaken or stirred when cooking is complete.
- When heating baby food, stir well after removing from microwave and test temperature before serving.

ADDING MOISTURE

- Microwave energy is attracted to water molecules.
- Food that is uneven in moisture content should be covered or allowed to stand so that the heat disperses evenly.
- Add a small amount of water to dry food to help it cook.

CLEANING AND CARE

1. Turn off the microwave and unplug the power cord from the wall when cleaning.
2. Keep the inside of the microwave clean. When food splatters or spilled liquids adhere to microwave walls, wipe with a damp cloth. Mild detergents may be used if the microwave gets very dirty. Avoid using spray or other harsh cleaners. They may stain, streak, or dull the door surface.
3. The outside of the microwave should be cleaned with a damp cloth. To prevent damage to the operating parts inside the microwave, water should not be allowed to seep into the ventilation openings.
4. Wipe the window on both sides with a damp cloth to remove any spills or splatters.
5. Do not allow the control panel to become wet. Clean with a soft, damp cloth. When cleaning the panel, leave the microwave door open to prevent it from accidentally turning on.
6. If steam accumulates inside or around the outside of the door, wipe with a soft cloth. This may occur when the microwave is operated under high humidity. This is normal.
7. It may be necessary to remove the glass tray for cleaning. Wash the tray in warm, soapy water or in a dishwasher.
8. The roller ring and microwave floor should be cleaned regularly to avoid excessive noise. Wipe the bottom surface of the microwave with a mild detergent.
8. The roller ring may be washed in mild, soapy water or in a dishwasher. When removing the roller ring, be sure to replace it in the proper position.
9. Remove odors from your microwave by combining a cup of water with the juice and skin of one lemon in a microwaveable bowl. Microwave for 5 minutes. Wipe thoroughly and dry with a soft cloth.
10. If the light bulb burns out, please contact customer service (1-800-324-0340) to have it replaced.
11. The microwave should be cleaned regularly and any food deposits should be removed. Failure to maintain the microwave in a clean condition could lead to deterioration of surfaces that could adversely affect the life of the unit and could possibly result in a hazardous situation.
12. Please do not dispose of this appliance into a regular garbage receptacle. Please check to see where you can dispose such appliances.

BEFORE CALLING FOR SERVICE

Before asking for service, please check each item below:

- Check to ensure the microwave is plugged in securely. If not, remove the plug from the outlet, wait 10 seconds, and plug it in again securely.
- Check for a blown circuit fuse or a tripped main circuit breaker. If these seem to be operating properly, test the outlet with another appliance.
- Check to ensure the control panel is programmed correctly and the timer is set.
- Check to ensure the door is securely closed, engaging the door lock system. If the door is not properly closed, the microwave energy will not flow inside.

SPECIFICATIONS

Power Consumption	120V, 60Hz, 1500W
Output	1000W
Operation Frequency	2450MHz
Outside Dimensions (HxWxD)	11 13/16 x 21 1/4 x 16 inches
Oven Cavity Dimensions (HxWxD)	9 7/16 x 13 15/16 x 14 1/8 inches
Oven Capacity	1.1 cu. ft.
Cooking Uniformity	Turntable System
Net Weight	Approx. 35.3 lbs.



© 2014 Sunbeam Products, Inc. doing business as Jarden Consumer Solutions. All rights reserved.

Oster® logo is a registered trademark of Sunbeam Products, Inc. used under license.

Distributed by Guangdong Galanz Microwave Oven and Electrical Appliances Manufacturing Co., Ltd.,
Shunde, Foshan, Guangdong, 528305, China.

For service, support and warranty information, call 1-800-324-0340.