

**BLADEZ<sup>®</sup>**

# **ECHELON GS**



## **OWNER'S MANUAL**

*Important: Read all instructions carefully before using this product. Retain this owner's manual for future reference.*

**FOR SERVICE PLEASE CONTACT BLADEZ FITNESS  
TOLL FREE: 866-325-2339**

# ***BLADEZ***<sup>®</sup>

## TABLE OF CONTENTS

<b>Title</b>	<b>Page</b>
Introduction	03
Warning Labels	04
Safety Information	05
Exercise Instruction	06
Training Guidelines	07
Suggested Stretches	11
Assembly Instructions	13
Notice and Inspection	16
Exploded View Drawing	17
Parts List	18
Console Overview	19
Maintenance & Cleaning	21
Warranty	22

## INTRODUCTION

Congratulations on your purchase of Bladez Fitness equipment. We hope you appreciate the style, quality, and value that exercisers across North America have come to expect from Bladez Fitness.

If you have any questions, concerns or product issues, do not return the equipment to the retail store. Instead, please call our Customer Service at 1-866-325-2339 or email us at [CustomerSupport@BHNorthAmerica.com](mailto:CustomerSupport@BHNorthAmerica.com).

Carefully read through the instructions contained in this manual. They provide you with important information about assembly, safety, fitness and use of the machine. Please read ALL the safety information contained on the following page.

# ASSEMBLY INSTRUCTIONS AND WARNING LABELS



## WARNING

- Misuse of this machine may result in serious injury.
- Read User's Manual prior to use and follow all warnings and instructions.
- Do not allow children on or around the machine.
- This bike does not free-wheel. Pedals continue to spin when you stop pedaling.
- Spinning pedals can cause injury.
- Reduce pedal speed in a controlled manner.
- The user weight must not exceed 275 lbs/125 kgs.
- This product should always be used on a level surface.
- Replace label if damaged, illegible or removed.



## ATTENTION

- Mauvaise utilisation de cette machine peut entraîner des blessures graves
- Lisez le manuel d'utilisateur avant l'utilisation, et suivez tous les avertissements et instructions.
- Ne laissez pas les enfants sur ou autour de l'appareil
- Ce vélo n'est pas roue libre. Les pédales continue a tourné lorsque vous arrêtez de pédaler
- Les pédales qui roules peuvent causer des blessures
- Réduisez la vitesse des pédales sous une manière contrôlable
- Le poids de l'utilisateur ne doit pas dépasser 275 lbs/125 kgs
- Ce produit doit toujours être utiliser sur une surface plane
- Remplacer l'étiquette si elle est endommagée, illisible ou enlevé

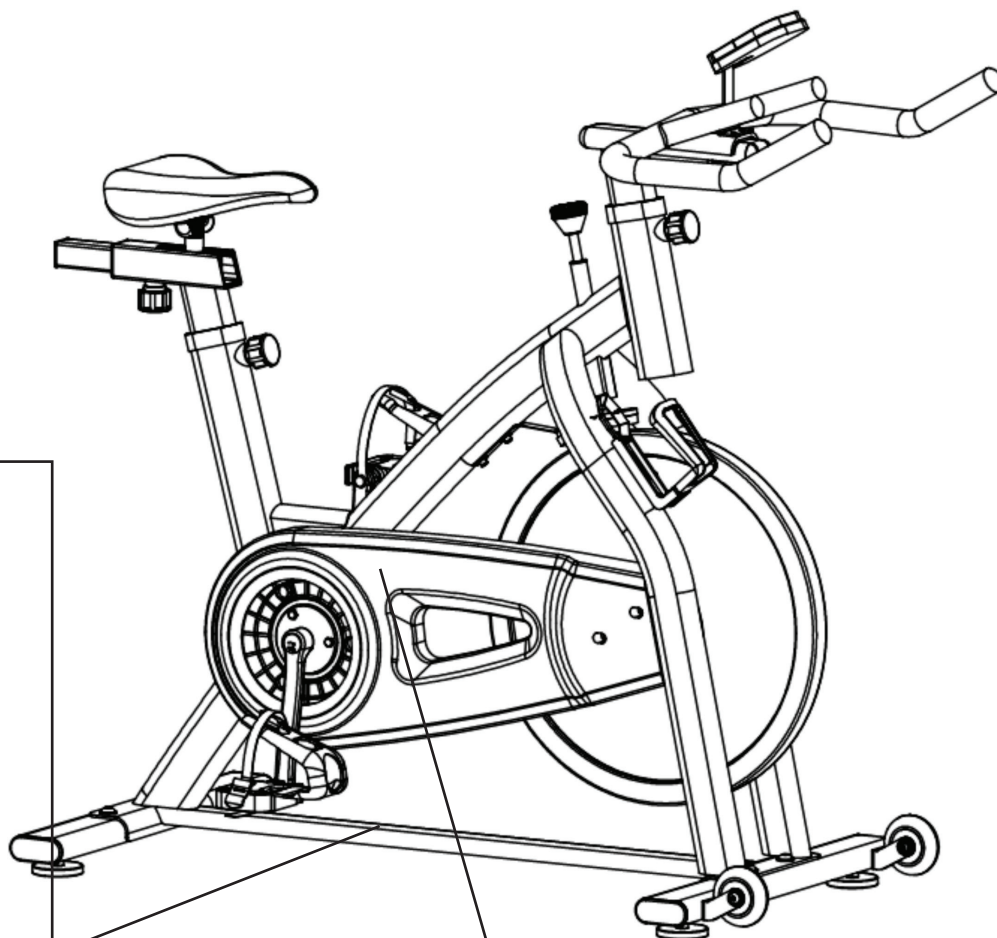

## WARNING

Keep hands and fingers clear of this area.



## ATTENTION

Garder les mains et les doigts en dehors de cette région

# SAFETY INFORMATION

## PRECAUTIONS

The machine has been designed and constructed to provide maximum safety. Nevertheless, certain precautions should be taken when using exercise equipment. Read the whole manual before assembling and using the machine. Please observe the following safety precautions:

1. Keep children and pets away from this equipment at all times. DO NOT leave them unsupervised in the room where the machine is kept.
2. If you experience dizziness, nausea, chest pains or any other symptom while using this machine STOP the exercise. SEEK IMMEDIATE MEDICAL ATTENTION!
3. Use the machine on a level and solid surface. Adjust the stabilizer for stability.
4. Keep your hands away from any of the moving parts.
5. Wear clothing suitable for doing exercise. Do not wear loose clothing that might get caught in the machine. Always wear athletic shoes when using the machine.
6. This machine must only be used for the purposes described in this manual. DO NOT use accessories that are not recommended by Bladez Fitness.
7. Do not place sharp objects near the machine.
8. Any person with physical or coordination limitations should not use the machine without the assistance of a qualified person or doctor.
9. Do warm-up stretching exercises before using the equipment.
10. Do not use the machine if it is not working correctly.
11. Before using the machine, thoroughly inspect the equipment for proper assembly.
12. Keep a perimeter of 3 feet (1 meter) around the machine before operating the equipment.
13. This machine is not suitable for therapeutic use.
14. Use only authorized and trained technicians if a repair is needed.
15. Please follow the advice for correct training, as detailed in the Training Guidelines.
16. This machine has been designed for home use, not for commercial use.
17. Use only the tools provided to assemble this machine.
18. The moving pedals can cause injury.
19. This machine was designed for a maximum user weight of 275 Lbs (125kg).
20. The machine can only be used by one person at a time.
21. Don't exceed the MAX mark when adjusting the handlebar post or seat post. Be sure the adjustment knob is fully tightened and seat and handlebars are secure.
22. This bike does not free-wheel. You can stop the bike quickly by applying pressure to the emergency hand brake, located on the handlebars.
23. Inspect the exercise bicycle for worn or loose components prior to use. Tighten/replace any loose or worn components prior to using.
24. Care should be taken in mounting or dismounting the exercise bicycle.

**Caution:** Consult your doctor before beginning to use the machine or any exercise program. Read all of the instructions before using any exercise equipment.

KEEP THESE INSTRUCTIONS SAFE FOR FUTURE USE.

## EXERCISE INSTRUCTION

Use of the machine offers various benefits; it will improve fitness, muscle tone and when used in conjunction with a calorie controlled diet, it will help you lose weight.

1. Consult your doctor before starting any exercise program. It is advisable to undergo a complete physical examination.
2. Work at the recommended exercise level. Do not over exert yourself.
3. If you feel any pain or discomfort, stop exercising immediately and consult your doctor.
4. Wear appropriate clothing and footwear for the exercise; do not wear loose clothing; do not wear leather soled shoes or footwear with high heels.
5. It is advised that you do warm-up stretches before working out.
6. Step on to the equipment slowly and securely.
7. Select the program or workout option that is most closely aligned with your workout interests.
8. Start slowly and work your way up to a comfortable pace.
9. Be sure to cool down after your workout.

## TRAINING GUIDELINES

Exercise is one of the most important factors in the overall health of an individual. Listed among its benefits are:

- Increased capacity for physical work (strength endurance)
- Increased cardiovascular (heart and arteries/veins) and respiratory efficiency
- Decreased risk of coronary heart disease
- Changes in body metabolism, e.g. losing weight
- Delaying the physiological effects of age
- Reduction in stress, increase in self-confidence, etc.

There are several components of physical fitness and each is defined below.

### *STRENGTH*

The capacity of a muscle to exert a force against resistance. Strength contributes to power and speed.

### *MUSCULAR ENDURANCE*

The capacity to exert a force repeatedly over a period of time, e.g. it is the muscular endurance of your legs to carry you 10 km without stopping.

### *FLEXIBILITY*

The range of motion of your joints. Improving flexibility involves the stretching of muscles and tendons to maintain or increase suppleness, and it provides increased resistance to muscle injury or soreness.

### *CARDIO-RESPIRATORY ENDURANCE*

The most essential component of physical fitness. It is the efficient functioning of the heart and lungs.

### *AEROBIC FITNESS*

Is an exercise of relatively low intensity and long duration, which depends primarily on the aerobic energy system. Aerobic means "with oxygen", and refers to the use of oxygen in the body's metabolic or energy-generating process. Many types of exercise are aerobic, and by definition are performed at moderate levels of intensity for extended periods of time.

### *ANAEROBIC TRAINING*

Is an exercise intense enough to trigger anaerobic metabolism. This means "without oxygen" and is the output of energy when the oxygen supply is insufficient to meet the body's long term energy demands. (For example, a 100 meter sprint.)

### *OXYGEN UPTAKE*

The effort that you can exert over a prolonged period of time is limited by your ability to deliver oxygen to the working muscles. Regular vigorous exercise produces a training effect that can increase your aerobic capacity by as much as 20 to 30%. An increased VO2 Max indicates an increased ability of the heart to pump blood, of the lungs to ventilate oxygen, and of the muscles to take up oxygen.

### *THE TRAINING THRESHOLD*

This is the minimum level of exercise which is required to produce significant improvements in any physical fitness parameter.

### *OVERLOAD*

This is where you exercise above your comfort level. The intensity, duration and frequency of exercise should be above the training threshold and should be gradually increased as the body adapts to the increasing demands. As your fitness level improves, the training threshold should rise. Working through your program and gradually increasing the overload factor is important.

### *PROGRESSION*

As you become more fit, a higher intensity of exercise is required to create an overload and therefore provide continued improvement.

### *SPECIFICS*

Different forms of exercise produce different results. The type of exercise that is carried out is specific to the muscle groups being used and to the energy source involved. There is little transfer of the effects of exercise, i.e. from strength training to cardiovascular fitness. That is why it is important to have an exercise program tailored to your specific needs.

### *REVERSIBILITY*

If you stop exercising or do not do your program often enough, you will lose the benefits you have gained. Regular workouts are the key to success.

### *WARM-UP*

Every exercise program should start with a warm-up where the body is prepared for the effort to come. It should be gentle and preferably use the muscles group to be involved later. Stretching should be included in both your warm-up and cool down, and should be performed after 3-5 minutes of low intensity aerobic activity or callisthenic type exercise.

### *WARM DOWN OR COOL DOWN*

This involves a gradual decrease in the intensity of the exercise session. Following exercise, a large supply of blood remains in the working muscles. If it is not returned promptly to the central circulation, pooling of blood may occur in the muscles.

### *HEART RATE*

As you exercise, your heart beat increases. This is often used as a measure of the required intensity of an exercise. You need to exercise hard enough to condition your circulatory system, and increase your pulse rate, but not enough to strain your heart.

Your initial level of fitness is important when developing an exercise program for you. When starting, you can get a good training effect with a heart rate of 110-120 beats per minute (BPM). If you are more fit, you will need a higher threshold of stimulation.

To begin with, you should exercise at a level that elevates your heart rate to about 65 to 70% of your maximum. If you find this is too easy, you may want to increase it, but it is better to lean on the conservative side.

As a rule of thumb, the maximum heart rate is 220 minus your age. As you increase in age, your heart, like other muscles, loses some of its efficiency. Some of its natural loss is won back as fitness improves. The following table is a guide to those who are “starting fitness.”

Age Target Heart Rate	25	30	35	40	45	50	55	60	65
10 Second Count	23	22	22	21	20	19	19	18	18
Beats per Minute	138	132	132	126	120	114	114	108	108

### *PULSE COUNT*

The pulse count (on your wrist or carotid artery in the neck, taken with two index fingers) is done for ten seconds, taken a few seconds after you stop exercising. This is for two reasons: (a) 10 seconds is long enough for accuracy, (b) the pulse count is to approximate your BPM rate at the time you are exercising. Since heart rate slows as you recover, a longer count isn't as accurate.

The target is not a magic number, but a general guide. If you're above average with your fitness, you may work comfortably a little above that suggested for your age group. The following table is a guide.

Age Target Heart Rate	25	30	35	40	45	50	55	60	65
10 Second Count	26	26	25	24	23	22	22	21	20
Beats per Minute	156	156	150	144	138	132	132	126	120

Don't push yourself too hard to reach the figures on this table. It can be very uncomfortable if you over exercise. Let it happen naturally as you work through your program. Remember, the target is a guide, not a rule, a little above or below is just fine.

Two final comments: (1) don't be concerned with day to day variations in your pulse rate, being under pressure or not enough sleep can affect it; (2) your pulse rate is a guide, don't become a slave to it.

### *MUSCLE SORENESS*

For the first week or so, muscle soreness may be the only indication you have that you are on an exercise program. This, of course, does depend on your overall fitness level. A confirmation that you are on the correct program is a very slight soreness in most major muscle groups. This is quite normal and will disappear in a matter of days.

If you experience major discomfort, you may be on a program that is too advanced, or you have increased your program too rapidly.

If you experience PAIN during or after exercise, your body is telling you something. Stop exercising and consult your doctor.

### *WHAT TO WEAR*

Wear clothing that will not restrict your movement in any way while exercising. Clothes should be light enough to allow the body to cool. Excessive clothing that causes you to perspire more than you normally would gives you no advantage. The extra weight you lose is body fluid and will be replaced with the next glass of water you drink. It is advisable to wear a pair athletic shoes.

### *BREATHING DURING EXERCISE*

Do not hold your breath while exercising. Breathe normally as much as possible. Remember, breathing involves the intake and distribution of oxygen, which feeds the working muscles.

### *REST PERIODS*

Once you start your exercise program, you should continue through to the end. Do not break off halfway through and then restart at the same place later on without going through the warm-up stage again. The rest period required between exercises may vary from person to person.

## SUGGESTED STRETCHES

### *Head Rolls*

Rotate your head to the right for one count while feeling the stretch up the left side of your neck. Next, rotate your head back for one count, stretching your chin to the ceiling. Rotate your head to the left for one count, and finally, drop your head to your chest for one count.

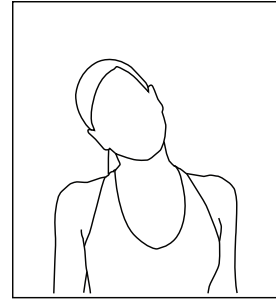

### *Shoulder Lifts*

Lift your left shoulder up toward your ear for one count. Then lift your right shoulder up for one count as you lower your left shoulder.

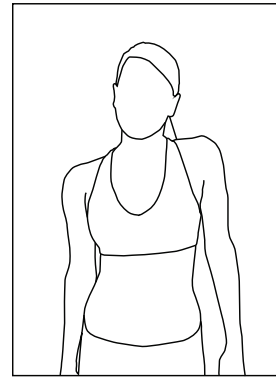

### *Side Stretches*

Open your arms to the side and continue lifting them until they are over your head. Reach your left arm as far upward as you can for one count. Feel the stretch up your left side. Repeat this action with your right arm.

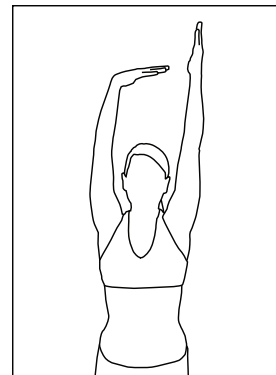

### *Quadriceps Stretch*

With one hand against a wall for balance, reach behind you and pull your left foot up. Bring your heel as close to your buttocks as possible. Hold for 15 counts and repeat with right foot up.

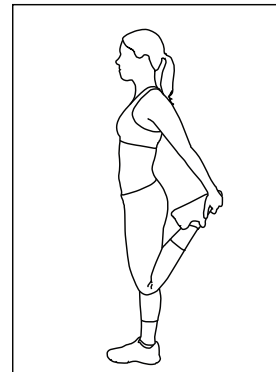

## SUGGESTED STRETCHES

### *Inner Thigh Stretch*

Sit with the soles of your feet together with your knees pointing outward. Pull your feet as close into your groin as possible. Gently push your knees towards the floor. Hold for 15 counts.

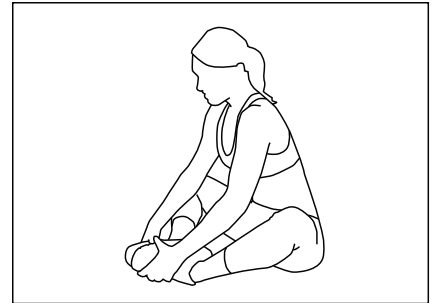

### *Toe Touches*

Slowly bend forward from your waist, letting your back and shoulders relax as you stretch toward your toes. Reach down as far as you can and hold for 15 counts.

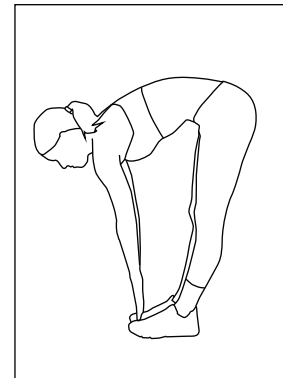

### *Hamstring Stretches*

Sit with your right leg extended. Rest the soles of your left foot against your right inner thigh. Stretch toward your toes as far as possible. Hold for 15 counts. Relax and then repeat with left leg extended.

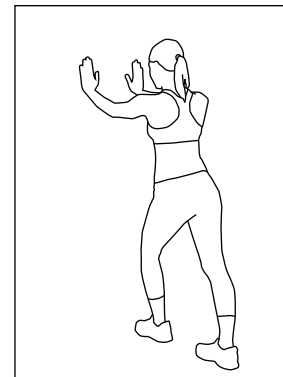

### *Calf/Achilles Stretches*

Lean against a wall with your right leg in front of the left and your arms forward. Keep your left leg straight and the right foot on the floor; then bend the right leg and lean forward by moving your hip toward the wall. Hold, then repeat on the other side for 15 counts.

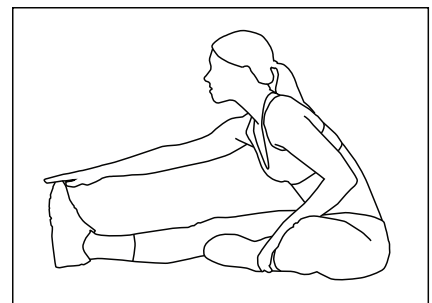

## ASSEMBLY INSTRUCTIONS

### STEP 1: Assemble Front & Rear Stabilizer Bars

Attach Front Stabilizer (65) to main frame (1) and secure it with 2 Hex Bolts (71) and washers (70). Attach Back Stabilizer (66) to main frame (1) and secure with 2 Hex Bolts (71) and washers (70).

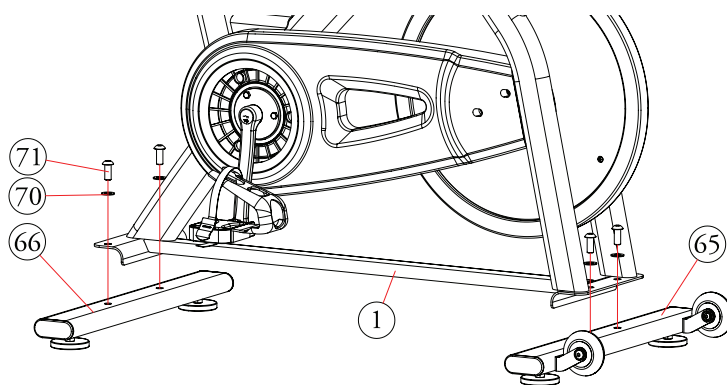

### STEP 2: Install Left/Right Pedals

Thread the Left Pedal (50) onto the left crank arm and tighten counter clockwise. Thread the Right Pedal (51) onto the right crank arm and tighten clockwise.

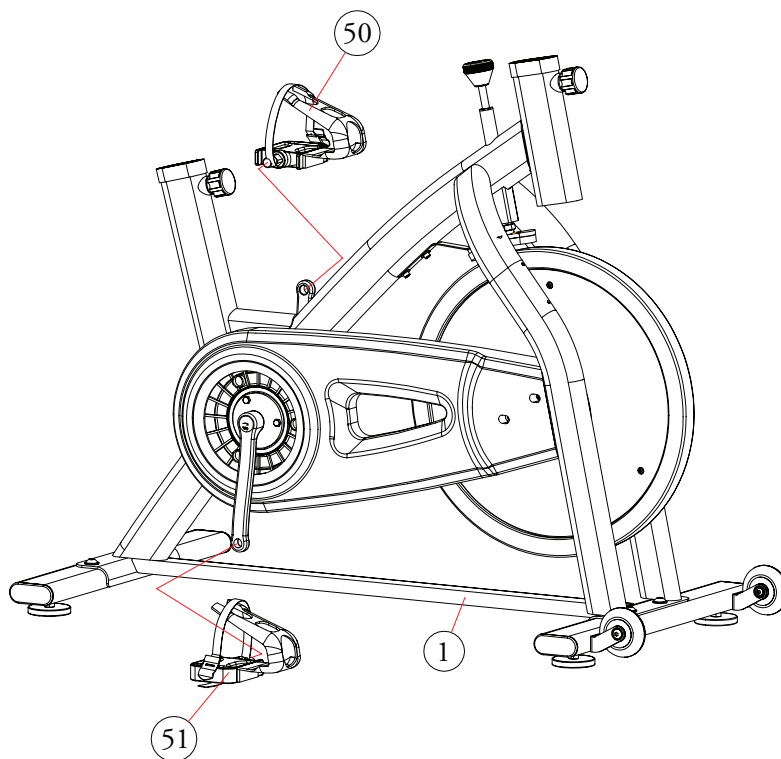

### STEP 3: Assemble the Handlebar Post

Loosen the Pop Pin (4), and slide the Handlebar Post (3) into the Handlebar Post Housing on the Main Frame (1), Secure by tightening Pop Pin (4).

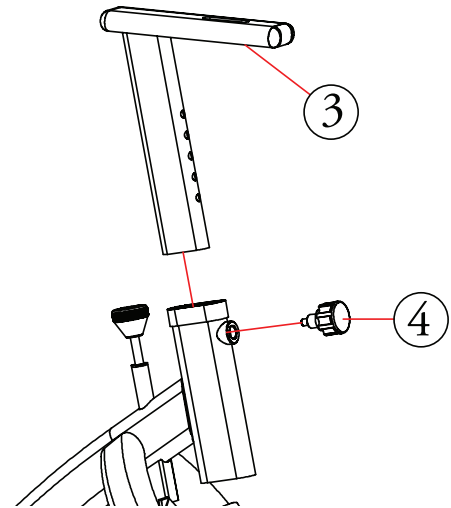

### STEP 4: Attach the Handlebar

Attach the Handlebar (2) to the Handlebar Post (3) to desired adjustable position. Tighten using Adjustment Knob (5) and Large Washer (34).

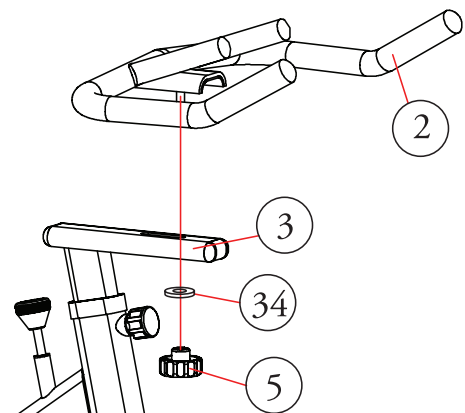

### STEP 5: Installing the Seat Post

Loosen the Pop Pin (4) and slide the Seat Post (8) into the Seat Post Housing on the Main Frame (1), then tighten the Pop Pin (4).

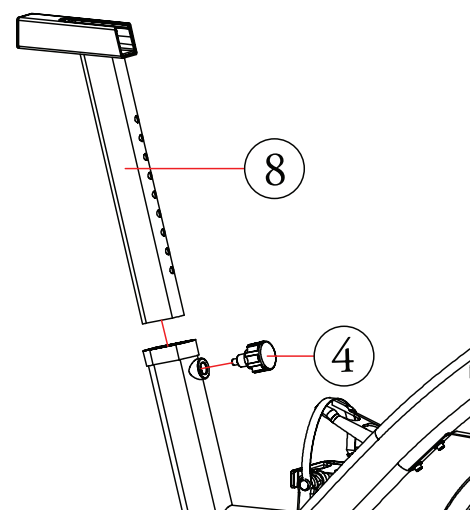

### STEP 6: Seat Assembly

Loosen the Pop Pin (4) and slide the Seat Slider (9) into the Seat Post (8) at desired height. Tighten the Pop Pin (4) Secure the Seat (12) to the Seat Slider (9).

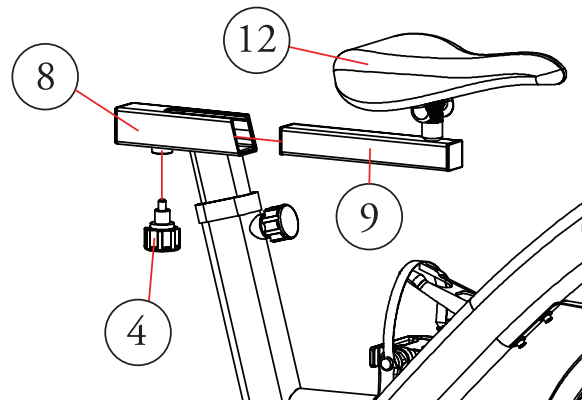

### STEP 7: Water Bottle Holder Installation

Attach the Water Bottle Holder (78) onto the right fork of the frame - there are two holes in the fork to align the water bottle holder. Align the Water Bottle Holder to the holes and secure with 2 washers (80) and 2 Umbrella Screws (79).

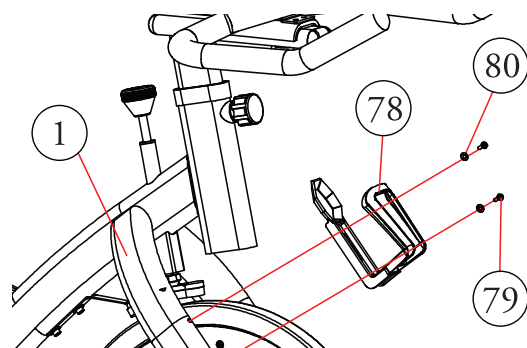

### STEP 8: Attach the Mount

Attach the computer mount (76) onto the handlebar (2) with 2 screws (77).

### STEP 8: Attach the Computer

Align back of computer (75) with computer mount (76) and slide the computer onto the computer mount. Connect computer cable with speed sensor cable from the bike.

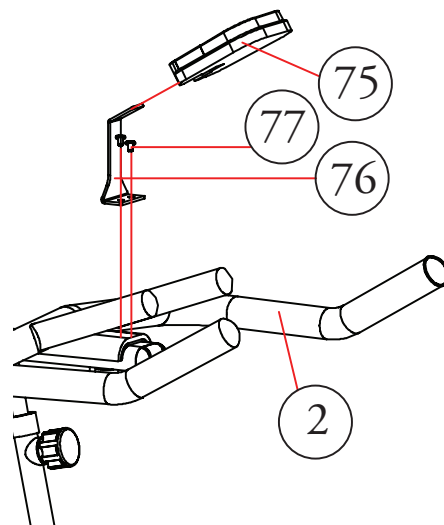

## NOTICE AND INSPECTION

1. Inspect the equipment periodically including the Nuts, Nut Caps and Pedals regularly. If you find any defective parts, replace them immediately. Don't exercise until they have been replaced.

2. Pay extra attention to areas that can wear over time. The figure to the right show the brake pad (20), please inspect before exercising, if it has fallen off please replace it before you begin exercising.

3. Please inspect the Pedals before exercising, if they are loose or missing, please tighten or replace before exercising.

4. If the seat (12) is loose, tighten the hex nut with the appropriate wrench.

5. If you need to move the bike, please grasp the Handlebar (2) at their very ends and pull down, this will make the wheels (72) of the Front Base touch the floor more easily.

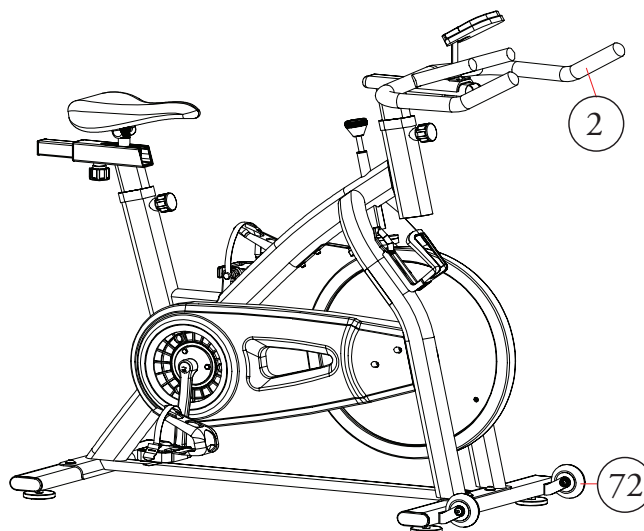
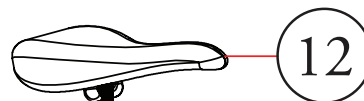
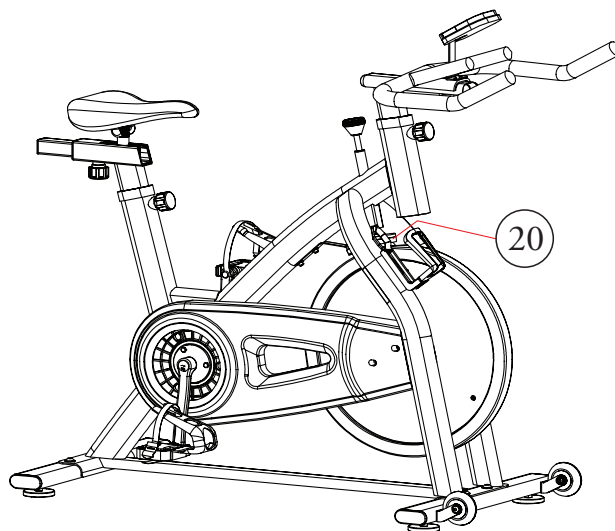

# EXPLODED VIEW DRAWING

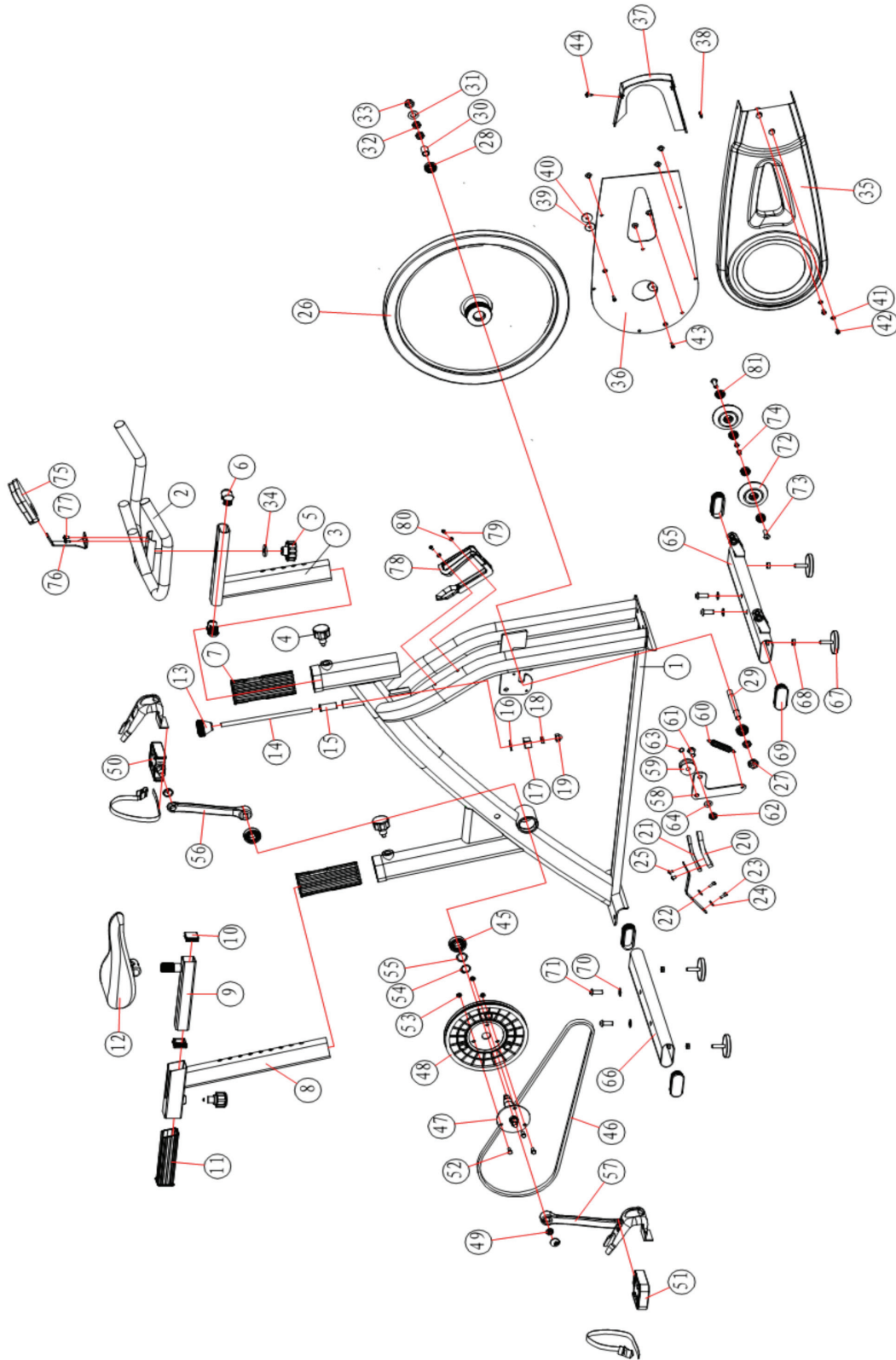

## PARTS LIST

NO.	Description	QTY	NO.	Description	QTY
EchelonGS-1	Frame	1	EchelonGS-42	Cross umbrella screw	2
EchelonGS-2	Handlebar	1	EchelonGS-43	Cross countersunk bolt	2
EchelonGS-3	Handlebar post	1	EchelonGS-44	Cross pan head self-tapping screw	8
EchelonGS-4	Pop pin	3	EchelonGS-45	Bearing 6004	2
EchelonGS-5	Adjustment knob	1	EchelonGS-46	Belt	1
EchelonGS-6	Cap of handlebar post	2	EchelonGS-47	Axle	1
EchelonGS-7	Plastic sheath of inner pipe	2	EchelonGS-48	Plastic belt wheel	1
EchelonGS-8	Seat post	1	EchelonGS-49	Hexagon flange nut	2
EchelonGS-9	Seat slider	1	EchelonGS-50	Left pedal	1
EchelonGS-10	Cap of square pipe	2	EchelonGS-51	Right pedal	1
EchelonGS-11	Sheath of seat post	1	EchelonGS-52	Hexagon bolt	3
EchelonGS-12	Seat	1	EchelonGS-53	Hexagon flange nut	3
EchelonGS-13	Resistance knob	1	EchelonGS-54	C shaped axle buckle	2
EchelonGS-14	Braking pole	1	EchelonGS-55	Waved mat	1
EchelonGS-15	Plastic sleeve tube	1	EchelonGS-56	Left crank	1
EchelonGS-16	Rubber mat	1	EchelonGS-57	Right crank	1
EchelonGS-17	Braking adjusting nut	1	EchelonGS-58	Tension bracket welding	1
EchelonGS-18	Hex nut	1	EchelonGS-59	Pressing wheel	1
EchelonGS-19	Cap nut	1	EchelonGS-60	Tension spring	1
EchelonGS-20	Braking pad	1	EchelonGS-61	Inner hexagon flat round head screw	1
EchelonGS-21	Braking pad holder	1	EchelonGS-62	Nylon nut	1
EchelonGS-22	Braking shrapnel piece	1	EchelonGS-63	C shaped axle buckle	1
EchelonGS-23	Inner hexagon column bolt	2	EchelonGS-64	Flat mat	1
EchelonGS-24	Bigger mat	2	EchelonGS-65	Front stabilizer	1
EchelonGS-25	Cross umbrella screw	2	EchelonGS-66	Back stabilizer	1
EchelonGS-26	PJ flywheel	1	EchelonGS-67	Foot leveler	4
EchelonGS-27	Flange nut	1	EchelonGS-68	Hex nut	4
EchelonGS-28	Bearing 6001	2	EchelonGS-69	Cap of stabilizer	4
EchelonGS-29	Flywheel spindle	1	EchelonGS-70	Flat mat	4
EchelonGS-30	Bushing	1	EchelonGS-71	Inner hexagon flat round head screw	4
EchelonGS-31	Flat mat	1	EchelonGS-72	Pulley	2
EchelonGS-32	Hexagon thin nut	3	EchelonGS-73	Inner hexagon hollow bolt	2
EchelonGS-33	Cap nut	1	EchelonGS-74	Inner hexagon flat round head screw	2
EchelonGS-34	Larger and thicker flat mat	1	EchelonGS-75	Meter	1
EchelonGS-35	Chain cover a	1	EchelonGS-76	Meter board	1
EchelonGS-36	Chain cover b	1	EchelonGS-77	Cross umbrella screw	2
EchelonGS-37	Front cover	1	EchelonGS-78	Water bottle shelf	1
EchelonGS-38	Shrapnel nut	1	EchelonGS-79	Cross umbrella screw	2
EchelonGS-39	Rubber mat	2	EchelonGS-80	Flat mat	2
EchelonGS-40	Chain cover plastic mat	2	EchelonGS-81	Bearing	4
EchelonGS-41	Flat mat	2			

## CONSOLE OVERVIEW

### SPECIFICATIONS:

TIME(TMR)	00:00-99:59 Minutes
ODOMETER(IF HAVE)	0.9999 KM or M
SPEED(SPD)	0.0-99.9 KM/H
PULSE(IF HAVE)	40-240 BPM
DISTANCE(DST)	0.00-999.9 KM
CALORIES(CAL)	0-9999 KCAL

### KEY FUNCTION:

1. **MODE:** Lets you select a particular function.
2. **PAUSE:** Press to start or stop the functions.
3. **SET:** Allows you to choose a target value for TIME ,DISTANCE,CALORIES, ODOMETER & PULSE.
4. **RESET:** Resets the value to zero.

### OPERATION PROCEDURES:

1. **AUTO ON/OFF:**
  - The system will turn on when any button is pressed or when it receives an input from the speed sensor.
  - The processor turns off automatically when the speed sensor has no signal input or no button has been pressed for more than 4 minutes.
2. **HOW TO CHANGE THE SPEED/DISTANCE FUNCTION FROM MILES TO KILOMETERS**
  - After installing the batteries in the console the default distance/speed measurement is in Miles and is noted by an M on the display in the speed (SPD) and distance (DIST) functions.
  - To change the distance/speed to Kilometers press the mode button for 3 seconds. The display will blink and the distance/speed is now Miles.
  - Kilometers are noted by a K on the display. To change back to Miles repeat the same procedure.
3. **RESET:** The unit can be reset by changing the batteries or pressing the RESET button for 3 seconds.
4. **HOW TO PRESET TIME, DISTANCE, ODOMETER, PULSE & CALORIES:**
  - Press the MODE button until the function to be preset is flashing.
  - Press the MODE button once the function stops flashing .
  - Next, choose the value you want to exercise by pressing the SET button.
  - When the speed sensor receives a signal, the monitor will begin to count down.
  - It will beep for 10 seconds to indicate the completion of preset workout, press any button to stop the beeping.
  - If data is not preset, functions will count up.

## **FUNCTIONS:**

- **TIME:** The time of exercise will be displayed by pressing MODE until TMR appears on the console.
- **SPEED:** Current speed will be shown by pressing MODE until DST appears on the console.
- **DISTANCE:** The distance of each workout will be displayed by pressing MODE until DST appears on the console.
- **ODOMETER:** Press the MODE button until the pointer advance to ODO, the total accumulated distance will be shown.
- **PULSE:** The current heart rate is displayed in beats per minute (BPM) by pressing MODE until PULSE appears on the console.
- **CALORIES:** The calories burned will be displayed by pressing the MODE button until CAL appears on the console.
- **SCAN:** Displays the followig functions in the order shown: TIME/SPEED/DISTANCE/ODOMETER/PULSE/CALORIES

## **BATTERY**

This monitor uses one AAA battery. If the monitor is not displaying correctly - install a new battery.

## MAINTENANCE & CLEANING

1. Care has been taken to assure that your bike has been properly adjusted and lubricated at the factory. It is not recommended that the user attempt service on the internal components; instead seek service from an authorized service center.
2. From time-to-time the outer surfaces may appear dull or dirty. Following the instructions listed below will restore and preserve the original finish.
3. Clean the handlebars and seat after each workout with a disinfectant spray, and remove any sweat from the bike frame.
4. Apply anti-rust to the flywheel every time you clean the machine or at least once a month. Apply a very light coat of oil in the contact surface of the flywheel with brake to avoid rattling noises.
5. Cleaning metal surfaces may be accomplished by using a soft cotton or terry cloth rag with a light application of car wax. Do not use aerosol sprays or pump bottles as they may deposit wax on the console surface.
6. From time-to-time the computer surface may collect dust or finger prints. The use of harsh chemicals will destroy the protective coating and cause a static build up that will damage the components. This surface may be cleaned with cleaning products found in most computer supply stores, specially made for antistatic surfaces. It is strongly recommended that you purchase such a cleaning compound.
7. The safety level of the equipment can only be maintained if it is regularly examined for damage and/or wear and tear.
8. Care must be taken when lifting or moving the equipment so as not to cause injury.
9. The brake pad is most susceptible to wear. Before exercising inspect the braking system for proper functionality.
10. Please check if all warning labels are in good condition and legible. If they are worn or damaged please contact the distributor to order new sticker.

**CLEANING:** Wipe sweat off the cycle immediately after each workout and then with a damp cloth. Clean dust from the cycle using a damp cloth or towel. Do not use solvents. Use a vacuum cleaner to clean around the cycle. The cycle may be cleaned underneath by laying it on its side. From time to time, check that all fasteners are properly secured and tightened. Check and tighten up all the parts on your unit every three months. Use of this machine with worn or weakened parts may cause the user injury. If you have any doubts about the condition of any part, we recommend that you replace it, using manufacturer's spare parts. Use of non original spare parts may cause injury or affect the performance of the machine.

## WARRANTY

### LIMITED RESIDENTIAL WARRANTY

BH North America will repair or replace, free of charge, at its option, parts that are defective as a result of material or workmanship. Lifetime replacement warranty coverage on frame and one (1) year on other parts. Labor warranty coverage is on (1) year. Warranty covers the original consumer purchaser only.

### THIS WARRANTY DOES NOT COVER

- Pre-delivery set-up.
- Components that require replacement due to dirt or lack of regular maintenance.
- Expendable items which become worn during normal use.
- Repairs necessary because of operator abuse or negligence or the failure to operate and maintain the equipment according to the instructions contained in the Owner's Manual.

For more detailed warranty information or to register your product warranty easily online, visit our website at: [www.BladezFitness.com](http://www.BladezFitness.com)

**FOR WARRANTY REPAIRS, PLEASE DO NOT TAKE YOUR MACHINE  
BACK TO THE RETAIL STORE. CONTACT BLADEZ FITNESS FIRST.**

Bladez Fitness/BH North America Corporation

20155 Ellipse

Foothill Ranch, CA 92610

Phone: 949.206.0330; Toll Free: 866.325.2339; Fax: 949.206.0013

Web: [www.bladezfitness.com](http://www.bladezfitness.com)

Mon - Fri 8am - 5pm PST