



OPERATOR'S MANUAL

12" Variable Speed Drill Press
with Laser Crosshair

Model # 4214



! IMPORTANT:

Your new tool has been engineered and manufactured to WEN's® high standards for dependability, ease of operation, and operator safety. Properly cared for, it will give you years of rugged, trouble-free performance.

Pay close attention to the Rules for Safe Operation, Warnings, and Cautions. If you use your tool properly and only for what it is intended, you will enjoy years of safe, reliable service.



Have product questions or need technical support? Please feel free to contact us!



WenProducts.com



[800-232-1195 M-F 8-5 CST](tel:800-232-1195)



techsupport@wenproducts.com

Table of Contents

Technical data.....	2
General safety rules.....	3
Specific safety rules for the drill press.....	5
Electrical information.....	6
Know your drill press.....	8
Assembly and adjustments.....	9
Operation.....	19
Maintenance.....	24
Troubleshooting.....	25
Replacement parts.....	27
Part List.....	28
Exploded view.....	30
One year limited warranty.....	31

Technical data

12" Variable Speed Drill Press with Laser Crosshair

Model # 4214

Motor:	120 V, 60 Hz, 4.8 A
Horsepower:	2/3 HP (single phase) Speed: 530–3100 RPM (no load)
Chuck capacity:	1/32–5/8" (0.8–16 mm) Quill
diameter:	2 3/16" (55 mm)
Stroke:	3 1/8" (80 mm)
Capacity:	6" (152 mm) (chuck to column) 19 1/2" (495 mm) (chuck to base)
Table tilt:	0 to 45 °left and right
Laser:	Class III, transformer powered
Weight:	85 lb

General safety rules

Safety is a combination of common sense, staying alert, and knowing how your drill press works.
SAVE THESE SAFETY INSTRUCTIONS.



WARNING: To avoid mistakes that could cause serious injury, do not plug in the drill press until the following steps have been read and understood.

1. **READ** and become familiar with this entire instruction manual. **LEARN** the tool's applications, limitations, and possible hazards.
2. **AVOID DANGEROUS CONDITIONS.** Do not use power tools in wet or damp areas or expose them to rain. Keep work areas well-lit.
3. **DO NOT** use power tools in the presence of flammable liquids or gases.
4. **ALWAYS** keep your work area clean, uncluttered, and well-lit. **DO NOT** work on floor surfaces that are slippery.
5. **KEEP BYSTANDERS AT A SAFE DISTANCE** from the work area, especially when the tool is operating. **NEVER** allow children or pets near the tool.
6. **DO NOT FORCE THE TOOL** to do a job that it was not designed to do.
7. **DRESS FOR SAFETY.** Do not wear loose clothing, gloves, neckties, or jewelry (rings, watches, etc.) when operating the tool. Inappropriate clothing and items can get caught in moving parts and draw you in. **ALWAYS** wear non-slip footwear and tie back long hair.
8. **WEAR A FACE MASK OR DUST MASK** as the drilling operation produces dust.



WARNING: Dust generated from certain materials can be hazardous to your health. Always operate this tool in a well-ventilated area and provide for proper dust removal. Use dust collection systems whenever possible.

9. **ALWAYS** remove the power cord plug from the electrical outlet when making adjustments, changing parts, cleaning, or working on the tool.
10. **KEEP GUARDS IN PLACE AND IN WORKING ORDER.**
11. **AVOID ACCIDENTAL START-UPS.** Make sure the power switch is in the OFF position before plugging in the power cord.
12. **REMOVE ADJUSTMENT TOOLS.** Always make sure all adjustment tools are removed from the drill press before turning it on.

General safety rules (continued)

13. NEVER LEAVE A RUNNING TOOL UNATTENDED. Turn the power switch to OFF. Do not leave the tool until it has come to a complete stop.
14. NEVER STAND ON A TOOL. Serious injury could result if the tool tips or is accidentally hit. DO NOT store anything above or near the tool.
15. DO NOT OVERREACH. Keep proper footing and balance at all times. Wear oil-resistant rubber-soled footwear. Keep the floor clear of oil, scrap, and other debris.
16. MAINTAIN TOOLS PROPERLY. ALWAYS keep tools clean and in good working order. Follow instructions for lubricating and changing accessories.
17. CHECK FOR DAMAGED PARTS. Check for alignment of moving parts, jamming, breakage, improper mounting, or any other conditions that may affect the tool's operation. Any part that is damaged should be properly repaired or replaced before use.
18. MAKE THE WORKSHOP CHILDPROOF. Use padlocks and master switches and ALWAYS remove starter keys.
19. DO NOT operate the tool if you are under the influence of drugs, alcohol, or medication that could affect your ability to use the tool properly.
20. USE SAFETY GOGGLES AT ALL TIMES—that comply with ANSI Z87.1. Normal safety glasses only have impact resistant lenses and are not designed for safety. Wear a face or dust mask when working in a dusty environment. Use ear protection, such as plugs or muffs, during extended periods of operation.



Laser safety

1. Do not stare directly at the laser beam. Eye damage may occur if you deliberately stare into the beam.
2. The laser light beam used in this system is Class III. AVOID DIRECT EYE EXPOSURE.
3. The laser must be used and maintained in accordance with the manufacturer's instructions:
 - Never aim the beam at any person or an object other than the workpiece.
 - Do not project the laser beam into the eyes of others.
 - Always ensure the laser beam is aimed at a workpiece without reflective surfaces as the laser beam could be projected into your eyes or the eyes of others.

 **AVOID EXPOSURE** - Laser radiation is emitted from this aperture.

EVITE LA EXPOSICIÓN - Desde esta abertura se emite radiación láser.

ÉVITER L'EXPOSITION - Des rayons laser sortent de cette ouverture.

DANGER

DANGER – LASER RADIATION – Do not stare into beam.

DANGER – RADIACIÓN LÁSER – No se exponga los ojos a los rayos.

DANGER – RAYONNEMENT LASER – Ne pas plonger les yeux dans le faisceau.

 5 mW MAX at 635 nm.
Class III A Laser Product.
Complies with 21 CFR 1040.10 and 1040.11.

Specific safety rules for the drill press



WARNING: Do not operate the drill press until it is completely assembled and installed according to the instructions.

1. Never turn the drill press on until the table is clear of all foreign objects (tools, scraps, etc.).
2. Always keep hands and fingers away from the drill bit.
3. Do not drill materials that do not have a flat surface—unless a suitable support is used (clamp or vise).
4. Never start the drill press with the drill bit pressed against the workpiece.
5. Make sure the table lock is tightened before starting the drill press.
6. Never layout, assemble, or set-up any work on the table while the drill is on.
7. Make sure drill bit is securely locked in the chuck.
8. Make sure chuck key is removed from the chuck before turning power on.
9. Adjust the table or depth stop to avoid drilling into the table.
10. Always stop the drill before removing scrap pieces from the table.
11. Use clamps or a vise to secure a workpiece to the table. This will prevent the workpiece from rotating with the drill bit.
12. Do not wear gloves when operating a drill press.
13. Set the drill press to the speed that is appropriate for the material being drilled.
14. Should any part of the drill press be missing, damaged, or any electrical component fail to perform properly, shut the power OFF and unplug the drill press. Replace missing, damaged, or failed parts before resuming operation.
15. Before leaving the machine, shut the power off, remove the drill bit, and clean the table.

Electrical information

Grounding instructions

IN THE EVENT OF A MALFUNCTION OR BREAKDOWN, grounding provides the path of least resistance for electric current and reduces the risk of electric shock. This tool is equipped with an electric cord that has an equipment grounding conductor and a grounding plug. The plug **MUST** be plugged into a matching outlet that is properly installed and grounded in accordance with ALL local codes and ordinances.

DO NOT MODIFY THE PLUG PROVIDED. If it will not fit the outlet, have the proper outlet installed by a licensed electrician.

IMPROPER CONNECTION of the equipment grounding conductor can result in electric shock. The conductor with the green insulation (with or without yellow stripes) is the equipment grounding conductor. If repair or replacement of the electric cord or plug is necessary, **DO NOT** connect the equipment grounding conductor to a live terminal.

CHECK with a licensed electrician or service personnel if you do not completely understand the grounding instructions, or if you are not sure if the tool is properly grounded.

USE ONLY THREE-WIRE EXTENSION CORDS that have 3-pronged plugs and outlets that accept the tool's plug as shown in Fig. A. Repair or replace a damaged or worn cord immediately.

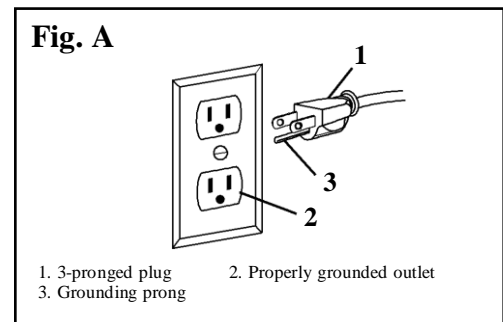

CAUTION: In all cases, make certain the outlet in question is properly grounded. If you are not sure if it is, have a licensed electrician check the outlet.

Electrical information (continued)



WARNING: This drill press is for indoor use only. Do not expose to rain or use in damp locations.

Guidelines for using extension cords

Make sure your extension cord is in good condition. When using an extension cord, be sure to use one heavy enough to carry the current your product will draw. An undersized cord will cause a drop in line voltage resulting in loss of power and overheating. The table below shows the correct size to be used according to cord length and nameplate ampere rating. If in doubt, use the next heavier gauge. The smaller the gauge number, the heavier the cord.

Minimum Gauge for Extension Cords (AWG)

(when using 120 V only)

Ampere rating		Total length of cord in feet (meters)			
More than	Not more than	25 (7.6)	50 (15)	100 (30.4)	150 (45.7)
0	6	18	16	16	14
6	10	18	16	14	12
10	12	16	16	14	12
12	16	14	12	Not recommended	

Make sure your extension cord is properly wired and in good condition. Always replace a damaged extension cord or have it repaired by a qualified person before using it.

Protect your extension cords from sharp objects, excessive heat and damp or wet areas.

Use a separate electrical circuit for your tools. This circuit must not be less than a #12 wire and should be protected with a 15 A time-delayed fuse. Before connecting the motor to the power line, make sure the switch is in the OFF position and the electric current is rated the same as the current stamped on the motor nameplate. Running at a lower voltage will damage the motor.



WARNING: This tool must be grounded while in use to protect the operator from electric shock.

Know your drill press

Fig. 1

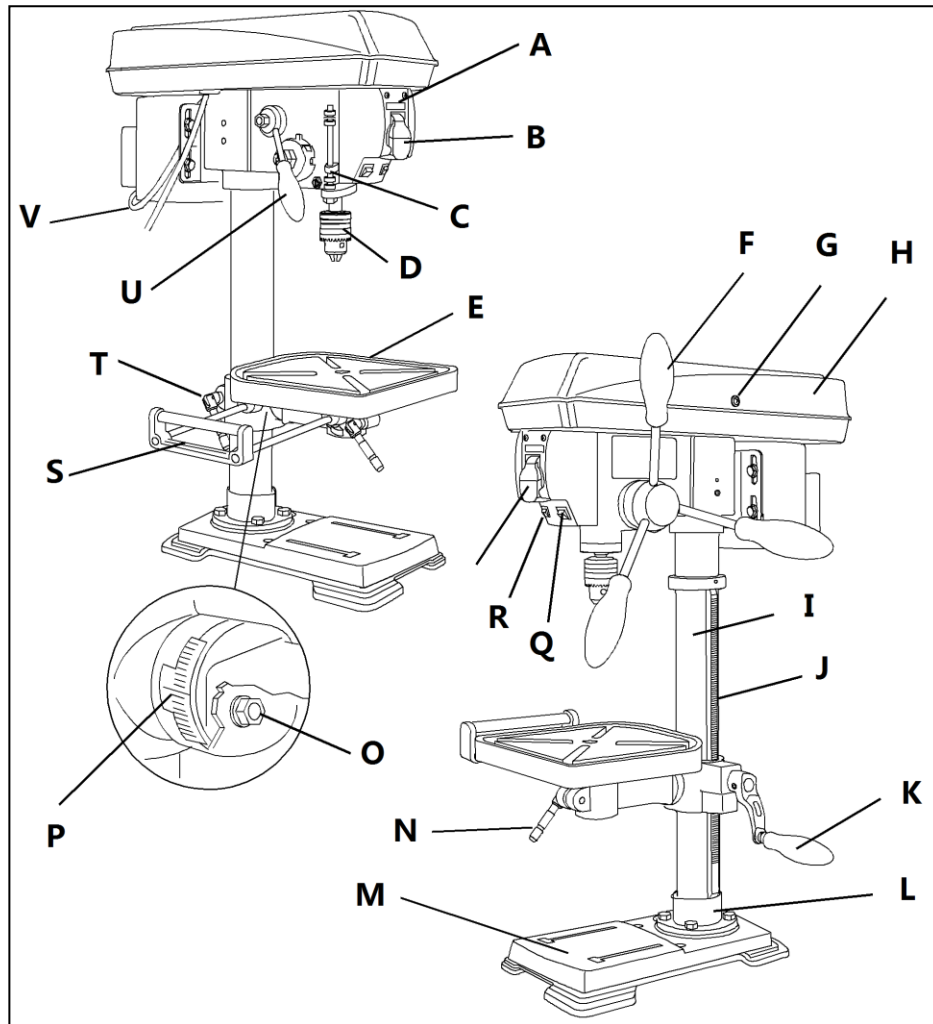

- | | | | | | |
|---|-----------------------|---|-------------------|---|--|
| A | Digital speed readout | I | Column | Q | Laser line ON/OFF switch |
| B | ON/OFF switch | J | Rack | R | LED worklight switch |
| C | Depth scale | K | Crank handle | S | Extension wing with integrated rollers |
| D | Chuck | L | Column support | T | Support lock handle |
| E | Table | M | Base | U | Speed control handle |
| F | Feed handles | N | Table lock handle | V | Power cord |
| G | Housing cover screw | O | Bevel lock bolt | | |
| H | Housing cover | P | Bevel scale | | |

Assembly and adjustments

Unpacking (Fig. 2)

Unpack the drill press and all its parts, and compare against the list below. Do not discard the carton or any packaging until the drill press is completely assembled.

To protect the drill press from moisture, a protective coating has been applied to the machined surfaces. Remove this coating with a soft cloth moistened with kerosene or WD-40®. Do not use acetone, gasoline, or lacquer thinner to clean. Apply a coat of good paste wax to the table and column. Wipe all parts with a clean dry cloth.

Fig. 2

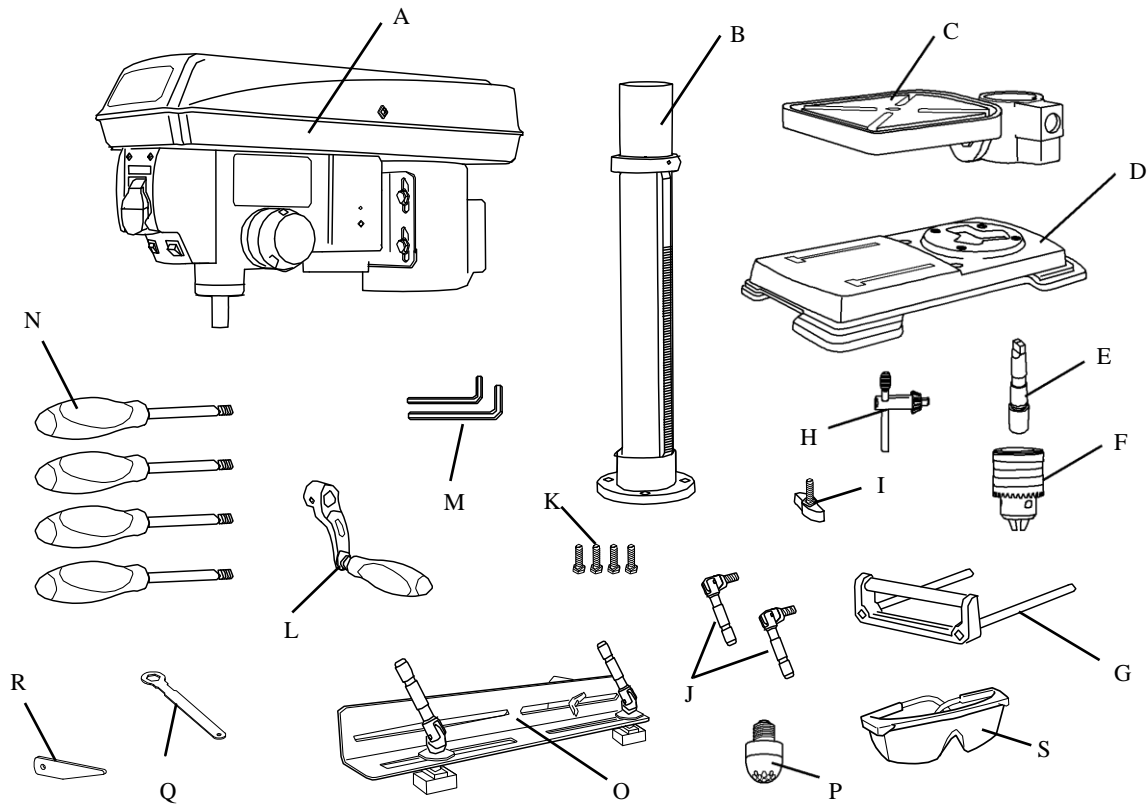

- | | | | |
|---|--|---|----------------------------|
| A | Head/motor assembly | K | Hex head bolts (4) |
| B | Column assembly and table bracket | L | Table crank handle |
| C | Table | M | Hex keys (2) |
| D | Base | N | Feed and speed handles (4) |
| E | Chuck arbor | O | Clamp assembly |
| F | Chuck | P | LED bulb |
| G | Extension wing with integrated rollers | Q | Table adjustment wrench |
| H | Chuck key | R | Wedge |
| I | Wing knobs (2) | S | Laser enhancing glasses |
| J | Table lock handles (2) | | |

Assembly and adjustments (continued)



WARNING: If any part is missing or damaged, do not plug the drill press in until the missing or damaged part is repaired or replaced, and assembly is complete.

The column assembly (column, column support, rack, rack collar, and table support bracket) must be attached to the base. The table and table support handles must be attached to the table support bracket. The motor housing must be attached to the column.

Tools needed for assembly

- Adjustable wrench
- □ screwdriver
- Hammer and block of wood

Column assembly to base (Fig. 3)

1. Place the column tube (1) on the base (2), aligning the column support holes to the base holes.
2. Install a hex head bolt (3) in each column support hole and tighten bolts using the adjustable wrench.

Table to table support bracket (Fig. 4)

1. Loose rack collar hex screw M8X10.
2. Remove rack collar and rack from column.
3. Place rack (teeth up) in slot of table support.
4. Slide table support with rack in slot onto column.
5. Slide rack collar down column onto beveled end of rack and tighten rack collar hex screw
6. Place the crank handle (1) onto the shaft (2) of the table bracket so the flat of the shaft is under the set screw (3). Tighten the set screw.
7. Thread the table lock handle (4) into the front of the table support bracket.
8. Thread the table support lock handle into the rear of the table support bracket (not shown).
9. Position the table (5) in the same direction as the base, install the table, and tighten the table lock handle (4).

Fig. 3

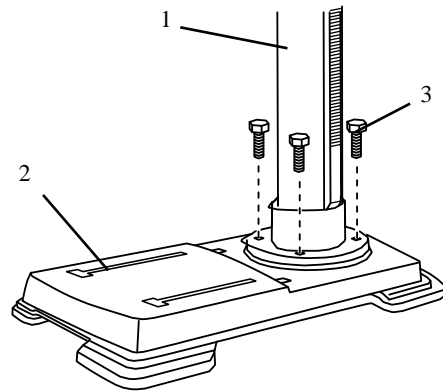
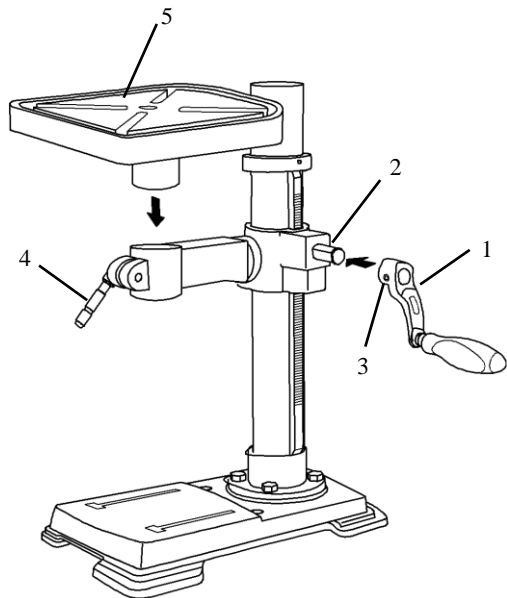

Fig. 4



Assembly and adjustments (continued)

Drill press head to column (Fig. 5)

CAUTION: The drill press head is heavy. To avoid injury, two people should lift it into position.

1. Carefully lift the drill press head assembly (1) and position it over the column (2).
2. Place the mounting opening (3) on the drill press head over the top of the column. Make sure the drill press head is seated properly on the column.
3. Align the direction of the drill press head with the direction of the base and the table.
4. Tighten the set screw (4) using a hex key.

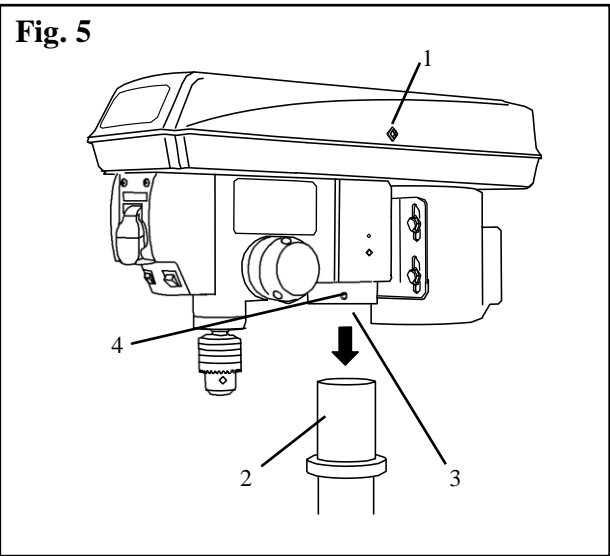

Feed handles (Fig. 6)

1. Insert the three feed handles (1) into the threaded openings on the feed hub (2).
 2. Manually tighten handles into openings.
- Note: When using the drill press, one or two of the feed handles may be removed if an unusually-shaped workpiece interferes with handle rotation.

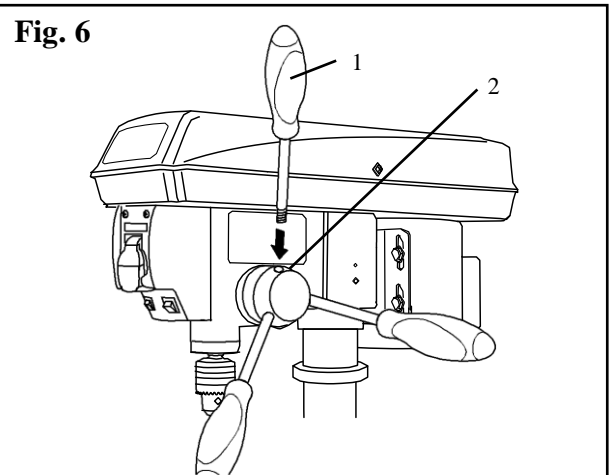

Speed handle (Fig. 7)

1. Insert the feed handle (1) into the threaded opening on the speed hub (2).
2. Manually tighten handle into opening.

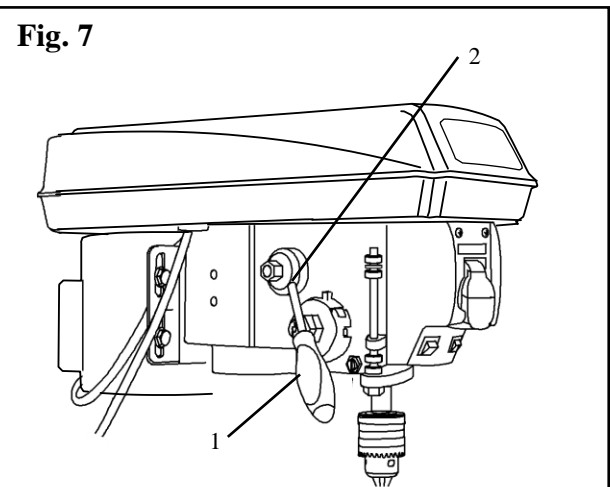

Assembly and adjustments (continued)

Mount the drill press (Fig. 8)

The drill press must be securely fastened through the mounting holes (1) to a stand or workbench with heavy-duty fasteners. This will prevent the drill press from tipping over, sliding, or walking during operation.

IMPORTANT: If the stand or workbench has a tendency to move during operation, fasten the workbench securely to the floor.

LED bulb (Fig. 9)

Insert the LED bulb (1) into the socket (2) in the motor head assembly.

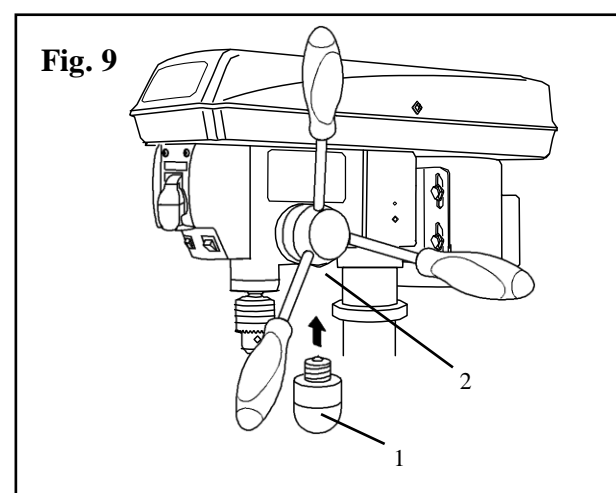
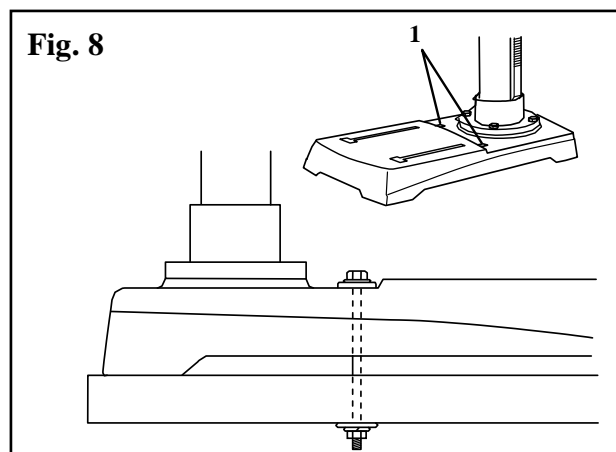

Assembly and adjustments (continued)

Chuck adjustments

Install the chuck (Fig. 10)

1. Inspect and clean the taper hole in the chuck (1) and the spindle (2). Remove all grease, coatings, and particles from the chuck and spindle surfaces with a clean cloth.
2. Open the chuck jaws (3) by manually turning the chuck barrel clockwise. Make sure the jaws are completely recessed inside the chuck.
3. Insert the chuck arbor (4) into the opening at the top of the chuck (1).
4. Seat the chuck and chuck arbor on the spindle by placing a block of wood (5; not included) under the chuck (1) and tapping the wood with a hammer (6; not included) or tap the chuck with a rubber mallet (not included).

CAUTION: To avoid damaging the chuck, make sure the jaws are completely recessed into the chuck. Do not use a metal hammer to drive the chuck into the spindle.

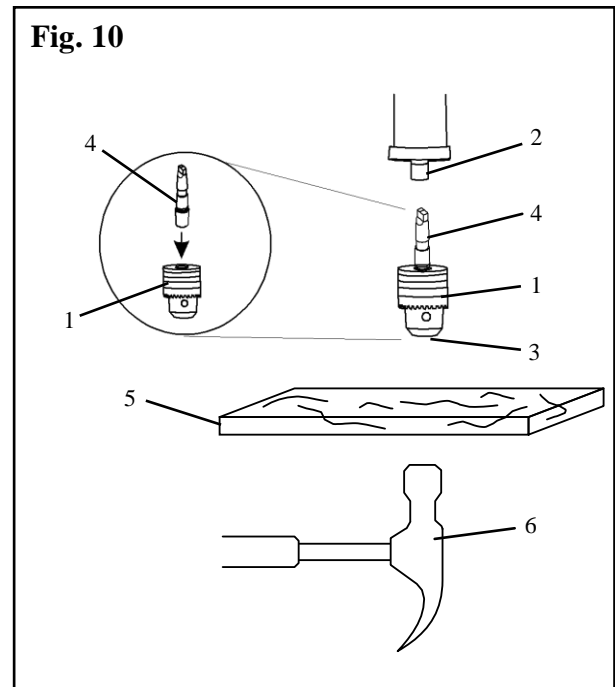

Remove the chuck (Fig. 11)

1. Turn the feed handles (1) to lower the chuck (2) to the lowest position.
2. Slide the wedge (3) into the opening in the quill. Tap on the wedge using a hammer (4; not included). The chuck and arbor will drop out.

Note: To avoid possible damage to the drill or chuck, be prepared to catch the chuck as it falls.

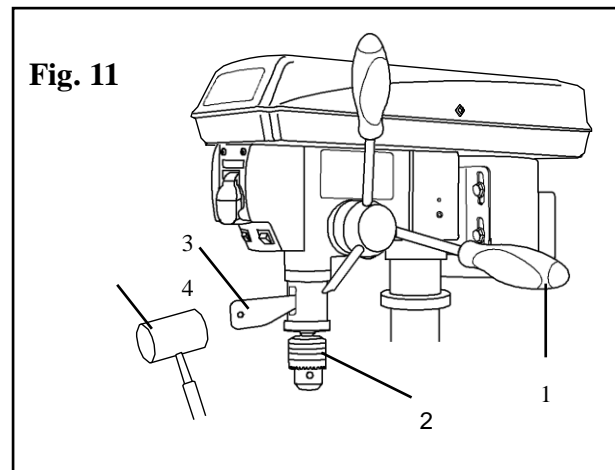

Assembly and adjustments (continued)

Table adjustments

Raise or lower the table (Fig. 12)

1. Loosen the support lock handle (1) and turn the crank handle (2) until the table is at the desired height.
2. Tighten the support lock handle before drilling.

Rotate the table (Fig. 12)

1. Loosen the support lock handle (1) and turn the table around the column to the desired position.

Note: The rack should rotate around the column with the table support bracket. If the rack binds and will not rotate, slightly loosen the set screw in the rack collar.

2. Tighten the support lock before drilling.

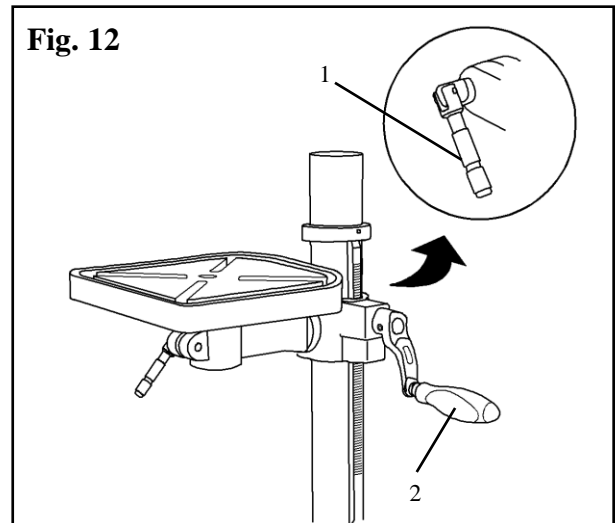

Tilt the table (Fig. 13)

1. Loosen the bevel lock bolt (1) with the table adjustment wrench provided, or with a suitable socket wrench.
2. Tilt the table to the desired angle, using the bevel scale (2) as a basic guide.
3. Re-tighten the bevel lock bolt.
4. To return the table to its original horizontal position, loosen the bevel lock bolt (1).
5. Realign the table to the 0° setting on the bevel scale (2).
6. Tighten the bevel lock bolt with the wrench.

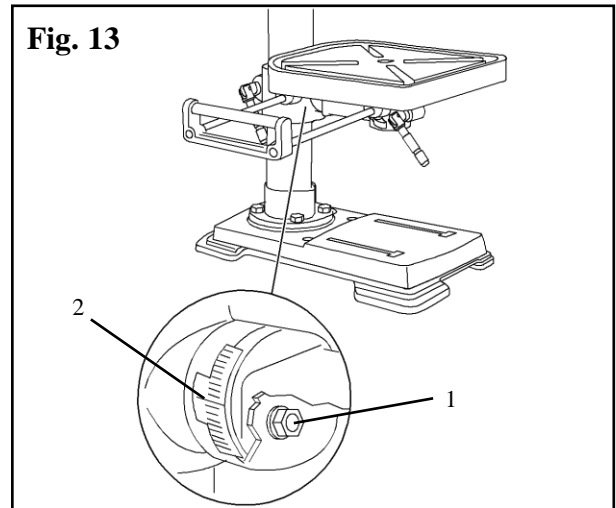

Install the table extension (Fig. 14)

1. Insert the two rods (1) of the table extension into the two channels (2) at the side of the table.
2. Place a wing knob (3) in the opening on the bottom of each channel and tighten to secure the extension to the table.

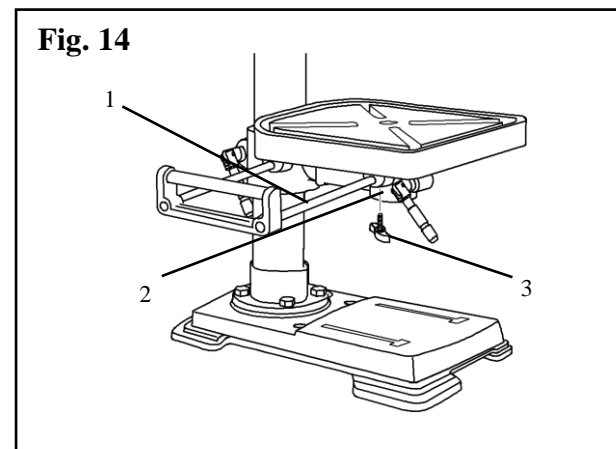

Assembly and adjustments (continued)



WARNING: To avoid injury, make sure the chuck key is removed from the chuck before starting any drilling operation.

Install drill bits (Fig. 15)

1. Place the chuck key (1) into the side keyhole of the chuck (2), meshing the key with the gear teeth.
2. Turn the chuck key counterclockwise to open the chuck jaws (3).
3. Insert a drill bit (4) into the chuck far enough to obtain maximum gripping of the chuck jaws.
4. Center the drill bit in the chuck jaws before final tightening of the chuck.
5. Tighten the chuck jaws using the chuck key to ensure that the drill bit will not slip while drilling.
6. Remove the chuck key.

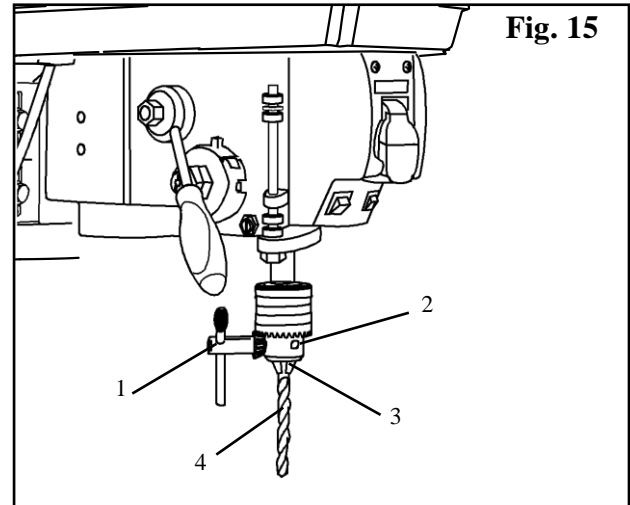

Square the table to the drill bit (Fig. 16)

1. Insert a 3" (7.6 cm) long drill bit (1) into the chuck (2) and tighten the jaws with the chuck key.
2. Raise the table with the crank handle (3), and lock the table (4) approximately 1" (2.5 cm) below the drill bit.
3. Place a combination square (5; not included) on the table as shown, placing the long straight edge of the combination square against the drill bit. Make sure the drill bit is parallel or aligned exactly to the straight edge of the square.
4. If an adjustment is needed, loosen the bevel lock bolt (6) with a wrench.
5. Tilt the table slightly, until the combination straight edge is aligned perfectly with the drill bit.
6. Tighten the bevel lock when square.

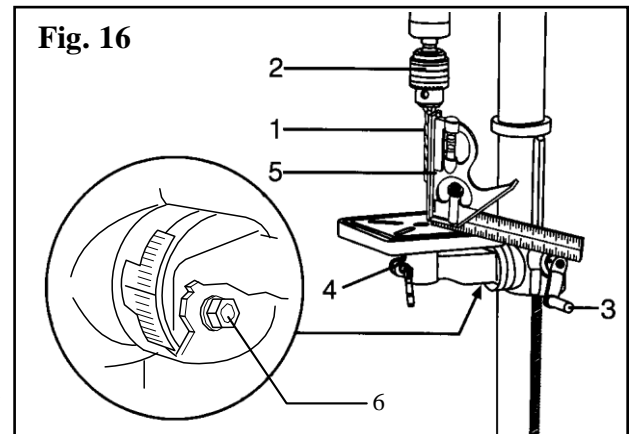

Note: Adjustments for the correct function of your drill press return spring have been done at the factory. Please do not modify them. However, prolonged use of the drill press may make some readjustments necessary.

Assembly and adjustments (continued)

Laser line (Fig. 17 and 18)



WARNING: Do not stare directly at the laser beam! A hazard may exist if you deliberately stare into the beam. Please observe all safety rules.

- Never aim the beam at any person or an object other than the workpiece.
- Do not project the laser beam into the eyes of others.
- Always make sure the laser beam is aimed at a workpiece that does not possess reflective surfaces as the laser beam could be projected into your eyes or the eyes of others.

1. Place a workpiece on the table.
2. Turn the laser switch (1) to the ON position.
3. Lower the drill bit to meet the workpiece (2). The two laser lines should cross where the drill meets the workpiece.
4. If the laser needs to be adjusted:
 - a. Using a 3 mm hex key, turn the laser adjustment set screws (3) counterclockwise.
 - b. Rotate the laser light housing (4) until the two laser lines intersect where the drill meets the workpiece. **DO NOT** stare directly at the laser lines.
5. Re-tighten the adjustment set screws (3).

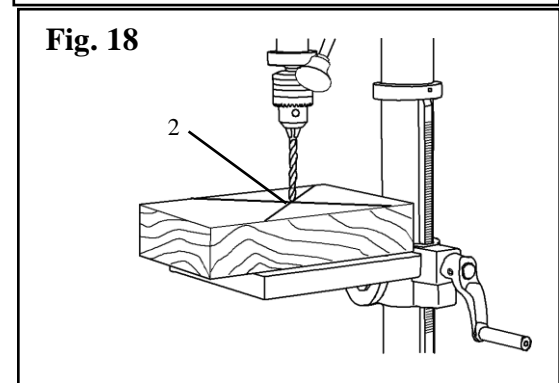
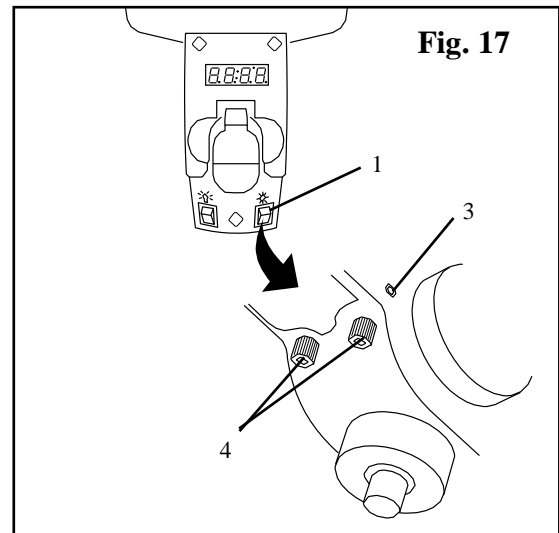

Assembly and adjustments (continued)

Spindle return spring (Fig. 19)

The spindle is equipped with an auto-return mechanism. The main components are a spring and a notched housing. The spring was properly adjusted at the factory and should not be readjusted unless absolutely necessary.

1. Unplug the drill press.
2. Place a screwdriver into the loop (1) to hold the spring in place.
3. Loosen the two housing nuts (2) approximately 1/4" (6 mm). **Do not remove the nuts from the threaded shaft. Do not allow the spring or spring housing to slip out of control.**
4. While firmly holding the spring housing (3), carefully pull the spring housing out until it clears the raised notch (4).
5. Turn the housing so that the next notch (5) is engaged with the raised notch (4).
 - To increase the spindle return tension, turn the spring housing counter-clockwise.
 - To decrease the tension, turn the spring housing clockwise.
6. Tighten the two housing nuts. Do not overtighten the two nuts. If the nuts are tightened too much, the movement of the spindle and feed handles will become sluggish.

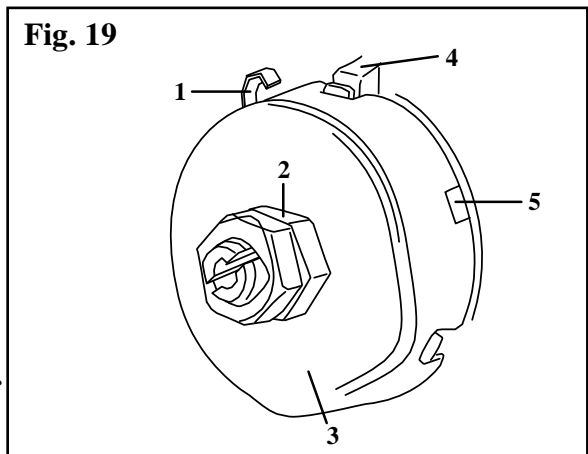
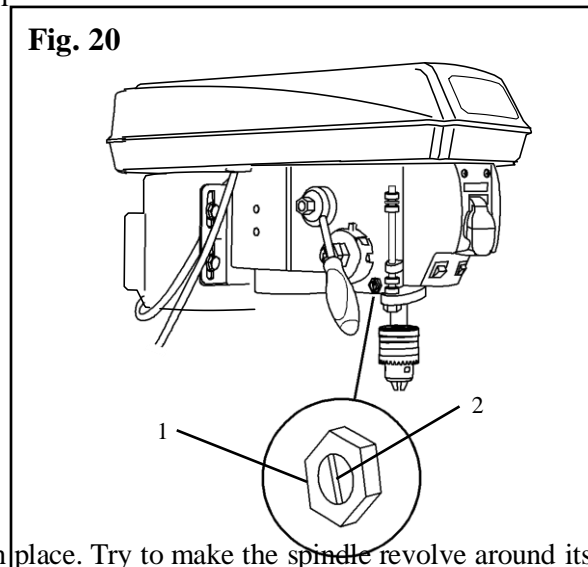

Fig. 20



Angular "play" of the spindle (Fig. 20)

Move the spindle to the lowest downward position and hold in place. Try to make the spindle revolve around its axis while also moving it with a side motion. If there is too much "play", proceed as follows:

1. Loosen the lock nut (1).
2. Without obstructing the upward and downward motion of the spindle, turn the screw (2) clockwise to eliminate the "play". Note: A little bit of "play" is normal.
3. Tighten the lock nut (1).

Assembly and adjustments (continued)

⚠ WARNING: Disconnect the drill press from the power source before replacing the belt.

Replace the belt (Fig. 21)

Belt tension and drill press speed is controlled by automatic adjustments made to the diameter of the front spindle when the drive handle is moved.

Note: See page 23 for information on the variable speed function of this drill press.

Remove the screw that secures the housing cover (1).
Open the housing cover.

Remove the belt (2) from the housing cover if it is broken. If it is not broken, but is too stretched to operate correctly, work the belt off the drive (motor) spindle (3). Then remove the belt from the front spindle (4).

Replace the belt by putting a new belt over the front spindle (4) and carefully sliding the belt over the drive (motor) spindle (3).

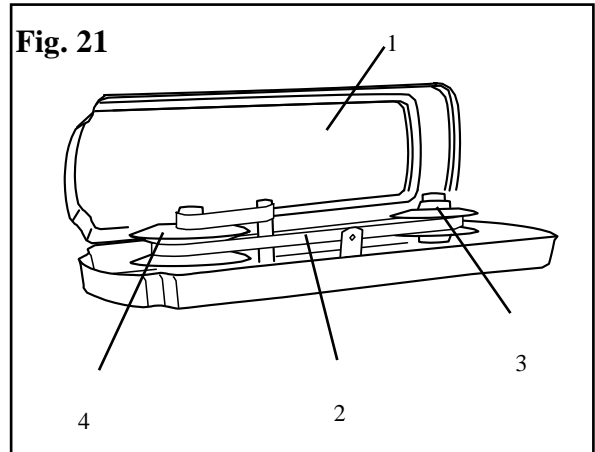

⚠ WARNING: Do not change the drive speed when the drill press is turned off.

Install the clamp assembly (Fig. 22)

1. Place the two metal squares (1) of the clamp assembly into two corners of the table and align the tapered edge of the squares with the grooves.
2. Align the long slots on the base of the clamp over the openings in the metal squares.
3. Place a washer (2) over the threaded end of each lock handle (3). Insert the lock handles into the metal squares. Tighten handles loosely.
4. Position the clamp as needed on the table and fully tighten the lock handles to secure the clamp.
5. Loosen the wing nut (4) to move the small support on the front of the clamp into position. Tighten the wing nut to secure.

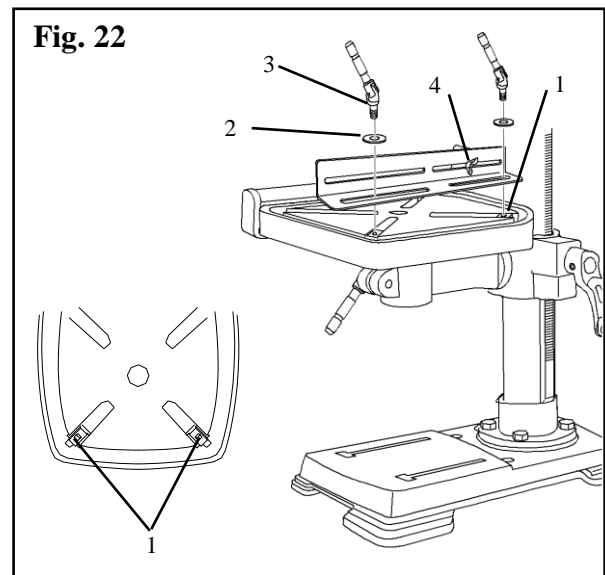

Operation

Drill Press ON/OFF switch (Fig. 23)

1. To turn the drill press ON, insert the yellow safety key (1) into the switch housing (2). As a safety feature, the switch cannot be turned ON without the safety key.
2. Flip the switch (3) upward to the ON position.
3. To turn the drill press OFF, press the switch downward.
4. To lock the switch in the OFF position, remove the safety key (1) from the switch. Store the safety key in a safe place.

Light and laser line ON/OFF switches (Fig. 23)

The light switch (4) is located below the ON/OFF switch on the left.

The laser switch (5) is located below the ON/OFF switch on the right.

Position the table and workpiece (Fig. 24)

Always place a piece of backup material (1) (wood, plywood, etc.) on the table underneath the workpiece (2). This will prevent splintering on the underside of the workpiece as the drill bit breaks through. To keep the material from spinning out of control, it must contact the left side (3) of the column as illustrated, or be clamped (4; not included) to the table.

Note: For small workpieces that cannot be clamped to the table, use a drill press vise (not included). The vise must be clamped or bolted to the table to avoid injury.

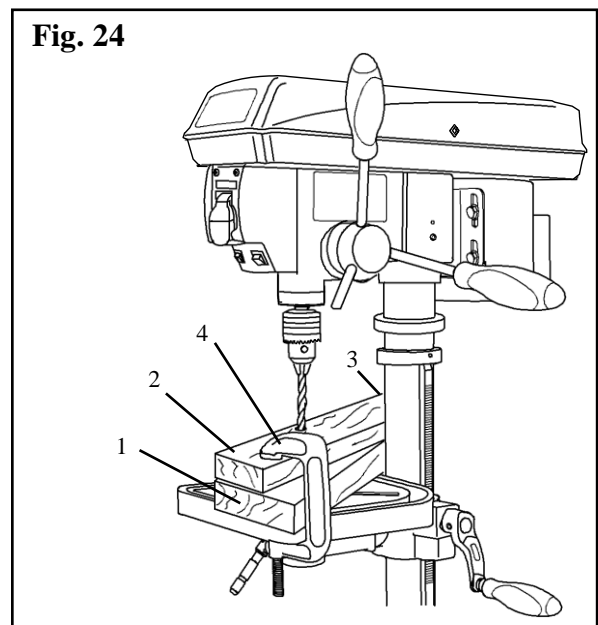
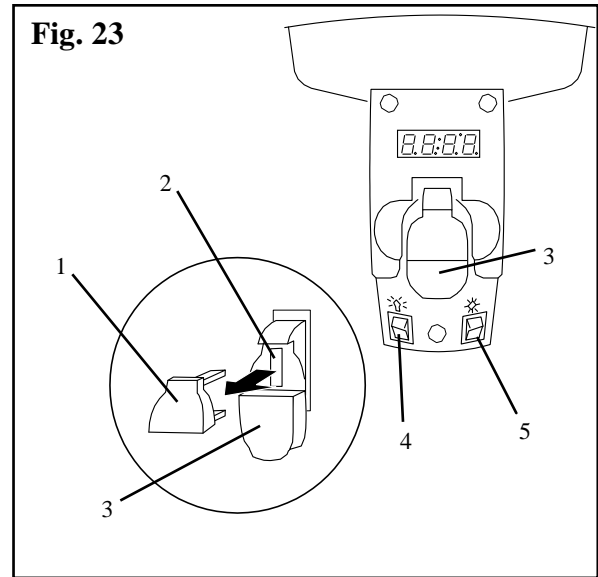

Operation (continued)

General drilling guidelines



WARNING: To prevent the workpiece and the backup material from slipping from your hand while drilling, position the workpiece and backup material to the left side of the column. If the workpiece and the backup material are not long enough to reach the column, clamp the workpiece and backup material to the table. Failure to do this could result in personal injury.

Drill a hole

1. Mark where you want to drill in workpiece by using a center punch or a sharp nail or turn ON Laser Line to mark drilling point.
2. Before turning ON the drill press, turn the feed handles to bring the drill bit down. Line the drill bit tip up with the mark. Clamp the workpiece in place.
3. Turn ON the drill press and pull down on the feed handles with appropriate force needed to allow the drill bit to drill material.

Note: Feeding too slowly might cause the drill bit to turn in the chuck. Feeding too rapidly might stop the motor, cause the belt to slip, force the workpiece loose, or break the drill bit. Practice with scrap material to get the feel of the machine before attempting to do any drilling operation.

Adjust the drilling depth (Fig. 25)

The depth gauge controls the maximum distance the drill bit will move up or down.

To stop the drill bit at a pre-measured depth:

1. Rotate the lower depth scale knob (2) until the bottom of the knob is aligned with the desired depth mark (5) on the gauge scale.
2. Rotate the depth scale lock knob (1) until it meets the lower depth scale knob (2). The chuck will stop after travelling downward to the selected distance.

Adjust the quill (return) height (Fig. 25)

To adjust the upward distance the quill (shaft that moves up and down) can travel:

1. Turn the feed handles until the quill is at the desired height and hold it there.
2. Rotate the lower depth knob (3) until it rests against the bottom of the metal gauge support (4).

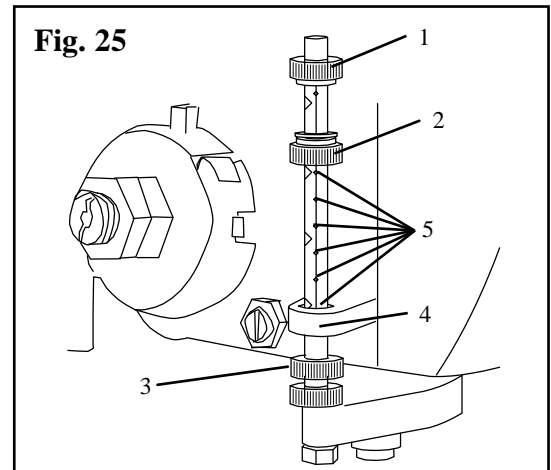

Operation (continued)

Drilling an unmeasured blind hole (not all the way through the workpiece) to a given depth can be done two ways: using the depth scale method or workpiece method.

Depth scale method (Fig. 26)

1. Make sure the 0 (" or mm) mark on the depth gauge rests at the top edge of the metal support (3) when the quill is fully retracted.
2. Put the workpiece on the table, and raise the table until the tip of the drill bit just touches the top of the workpiece. Lock the table in place.
3. Determine the drill depth for this workpiece.
4. Rotate the lower depth knob (2) until it is aligned with the desired depth mark (4) (for example, 1") on the gauge scale.
5. Rotate the upper depth lock knob (1) until it meets the lower depth knob (2). The chuck will be stopped at the distance selected on the depth scale.

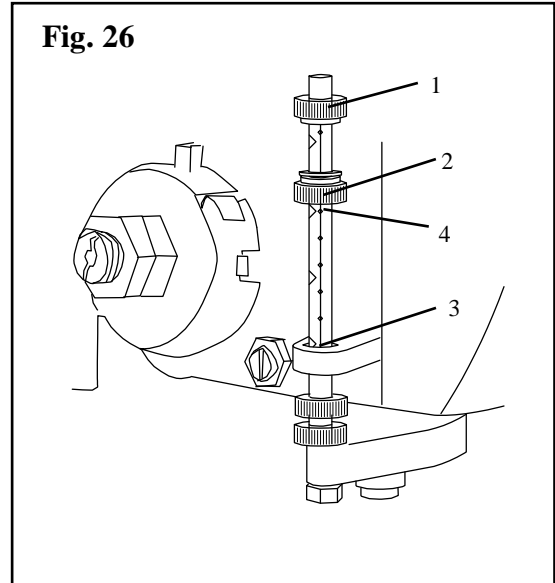

Workpiece method (Fig. 26 and 27)

1. Mark the desired depth (5) of the drill hole on the side of the workpiece.
2. With the drill press in the OFF position, bring the drill bit (6) down until the tip is even with the mark.
3. Holding the feed handles at this position, rotate the lower depth knob (2) until it meets the metal support.
4. Rotate the upper (1) depth scale lock knob until it meets the lower knob (2). The chuck and the drill bit will now be stopped at the distance selected on the depth scale.

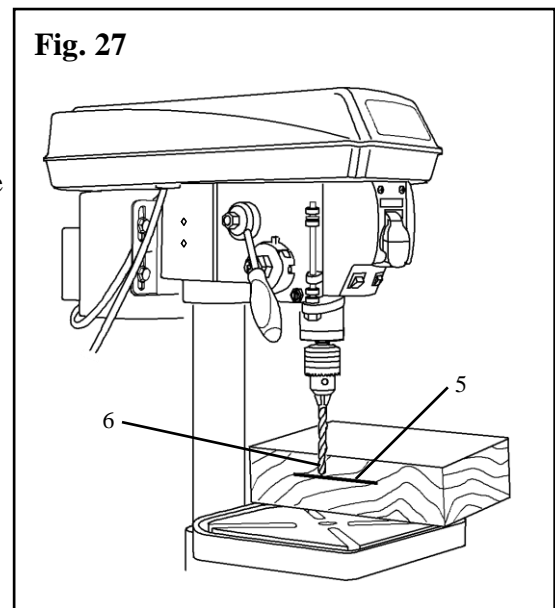

Operation (continued)

Drilling speeds

Important factors when determining the best drilling speed:

- Material type
- Hole size
- Drill bit or cutter type
- Quality desired

Smaller drill bits require greater speed than large drill bits. Softer materials require greater speed than harder materials. See page 23 for recommended speeds for the workpiece material.

Drilling metal

- Use metal-piercing twist drill bits.
- It is always necessary to lubricate the tip of the drill with oil to prevent overheating the drill bit.
- All metal workpieces should be clamped down securely. Any tilting, twisting, or shifting causes a rough drill hole, and increases the potential of drill bit breakage.
- Never hold a metal workpiece with your bare hands. The cutting edge of the drill bit may seize the workpiece and throw it, causing serious injury. The drill bit will break if the metal piece suddenly hits the column.
- If the metal is flat, clamp a piece of wood under it to prevent turning. If it cannot be laid flat on the table, then it should be blocked and clamped.

Drilling wood

- Brad point bits are preferred. Metal piercing twist bits may be used on wood.
- Do not use auger bits. Auger bits turn so rapidly that they can lift the workpiece off of the table and whirl it around.
- Always protect the drill bit by positioning the table so that the drill bit will enter the center hole when drilling through the workpiece.
- To prevent splintering, feed drill bit slowly when the bit is about to cut through to the backside of the workpiece.
- To reduce splintering and protect the point of the bit, use scrap wood as a backing or a base block under the workpiece.

Feeding the drill bit

- Pull down on the feed handles with only enough force to allow the drill bit to cut.
- Feeding too rapidly might stall the motor, cause the belt to slip, damage the workpiece, or break the drill bit.
- Feeding too slowly will cause the drill bit to heat up and burn the workpiece.

Operation (continued)

Mechanical variable speed (Fig. 28)

This is a mechanical variable speed drill press. To increase or decrease the speed when operating, raise or lower the speed handle (1).

Use the following table to determine the recommended speed for the drill size you are using and the type of material you are to drill. While drilling, check the speed on the digital speed readout (2) located at the front of the drill press.

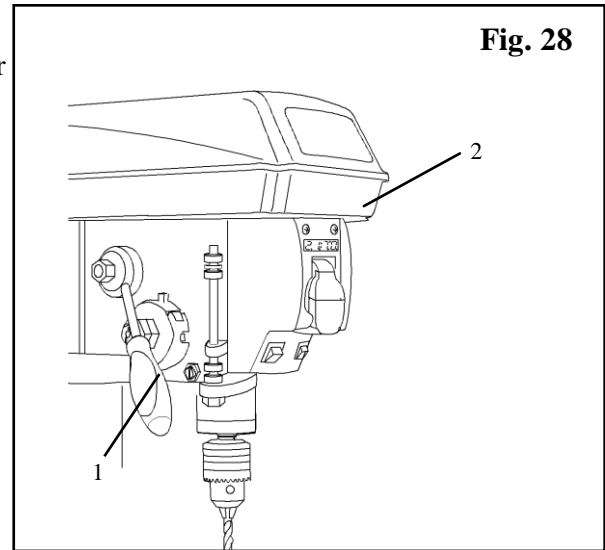

Fig. 28

Warning: Do not change speed without turn on the machine.

Recommended speed for drill bit size and materials

SPEED RANGE (RPM)	WOOD Drill bit size		ALUMINUM / ZINC / BRASS Drill bit size		IRON / STEEL Drill bit size	
	inches	mm	inches	mm	inches	mm
2000–3100	3/8	9.5	7/32	5.6	3/32	2.4
1400–2000	5/8	16.0	11/32	8.75	5/32	4.0
1000–1400	7/8	22.0	15/32	12.0	1/4	6.4
800–1000	1 1/4	31.75	11/16	17.5	3/8	9.5
530–800	1 5/8	41.4	3/4	19.0	5/8	16.0

Maintenance



WARNING: For your safety, turn the switch off and remove the plug from the power supply before maintaining or lubricating the drill press.

Vacuum sawdust or metal shavings that accumulates in and on the motor, pulley housing, table, and work surface.

Apply a light coat of paste wax to the column and table to help keep these surfaces clean and rust-free.

The ball bearings in the spindle and the V-belt pulley assembly are greased and permanently sealed. Pull the spindle down and oil the spindle sleeve moderately every three months.

Lubricate the table bracket and locking knobs if they become difficult to use.

CAUTION: All servicing of the drill press should be performed by a qualified service technician.

Troubleshooting

PROBLEM	PROBABLE CAUSE	REMEDY
Noisy operation	<ol style="list-style-type: none"> 1. Incorrect belt tension. 2. Dry spindle. 3. Loose spindle pulley. 4. Loose motor pulley. 	<ul style="list-style-type: none"> • Adjust the belt tension. See To replace the belt in Adjustments. • Lubricate the spindle. See Maintenance. • Tighten the retaining nut on the pulley insert. • Tighten the set screw on the side of the motor pulley.
The drill bit burns or smokes.	<ol style="list-style-type: none"> 1. Drilling at the incorrect speed. 2. The wood chips are not coming out of the hole. 3. Dull drill bit. 4. Feeding the workpiece too slowly. 5. Not lubricated. 	<ul style="list-style-type: none"> • Change the speed. See Variable speed in Operation. • Retract the drill bit frequently to clear the chips. • Resharpen or replace the drill bit. • Feed fast enough to cut the workpiece. See To drill a hole in Operation. • Lubricate the drill bit with cutting oil or motor oil.
Excessive drill run-out or wobble, drilled hole is not round.	<ol style="list-style-type: none"> 1. Bent drill bit. 2. Bit improperly installed in the chuck. 3. Worn spindle bearings. 4. Lengths of cutting flutes or angles not appropriate for the hardness of the wood grain. 5. Chuck not properly installed. 	<ul style="list-style-type: none"> • Replace the drill bit. • Reinstall the bit. See To install drill bits in Adjustments. • Replace bearings. Take to a qualified service technician. • Resharpen the drill bit correctly or replace with the appropriate type. • Reinstall the chuck. See To install the chuck in Assembly.
Drill bit binds in the workpiece.	<ol style="list-style-type: none"> 1. The workpiece is pinching the bit. 2. Excessive feed pressure. 	<ul style="list-style-type: none"> • Support or clamp the workpiece. See Position the table and workpiece in Operation. • Feed more slowly. See Feeding the drill bit in Operation.
Spindle returns too slowly or too quickly.	<ol style="list-style-type: none"> 1. Spring has improper tension. 	<ul style="list-style-type: none"> • Adjust the spring tension. See Spindle return spring in Adjustments.
Chuck falls off spindle.	<ol style="list-style-type: none"> 1. Dirt, grease, or oil on the tapered surface on the spindle or in the chuck. 	<ul style="list-style-type: none"> • Clean the tapered surface of both the chuck and the spindle with a household detergent. See To install the chuck in Assembly.

Troubleshooting (continued)

PROBLEM	PROBABLE CAUSE	REMEDY
The workpiece splinters on the underside.	1. No backup material under the workpiece.	<ul style="list-style-type: none"> • Always use a backup material. See Position the table and workpiece in Operation.
The workpiece is slipping from your hand.	1. Not supported or clamped properly.	<ul style="list-style-type: none"> • Support workpiece using extension wing or clamps. See Position the table and workpiece in Operation.
Motor will not run.	<ol style="list-style-type: none"> 1. Defective or broken switch. 2. Defective or damaged power cord. 3. Open circuit, loose connections, or burned out motor. 4. Blown fuse or circuit breaker. 5. Low voltage. 	<ul style="list-style-type: none"> • Take to a qualified service technician. • Take to a qualified service technician. • Take to a qualified service technician. • Replace fuse or reset circuit breaker. Turn off other machines on the same circuit. • Check the power line for the proper voltage. Use another circuit or have a qualified electrician upgrade the service.
Motor will not start and fuses or circuit breakers blow.	<ol style="list-style-type: none"> 1. Short circuit in motor or power cord. 2. Incorrect fuses or circuit breakers. 	<ul style="list-style-type: none"> • Take to a qualified service technician. • Replace with correct fuse or circuit breaker for the circuit.
Motor fails to reach full power.	<ol style="list-style-type: none"> 1. Overloaded circuit. 2. Improper extension cord. 	<ul style="list-style-type: none"> • Turn off other machines and retry. • Replace with proper size extension cord. See Electrical information.
Motor stalls.	<ol style="list-style-type: none"> 1. Short circuit in motor. 2. Incorrect fuses or circuit breakers. 3. Overloaded circuit. 4. Low voltage. 	<ul style="list-style-type: none"> • Take to a qualified service technician. • Replace with correct fuse or circuit breaker for the circuit. • Turn off other machines and retry. • Check the power line for the proper voltage. Use another circuit or have a qualified electrician upgrade the service.

Replacement parts

Service Information

Now that you have purchased your bench top power tool, should a need ever exist for service, simply call Great Lakes Technologies, LLC Service Department at (800) 232-1195 M-F 8-5 CST. Be sure to provide all pertinent facts when you call or visit.

Replacement Parts

Use only WEN® replacement parts. Use of any other parts may cause damage to your machine. When ordering replacement parts, please provide the model number, part number, and description.

Parts list

Item#	Part#	Description	Qty
1	4214-001	Pan Head ScrewM4x8	5
2	4214-002	Slider	2
3	4214-003	Baffle	1
4	4214-004	Base	1
5	4214-005	Column Clamp	2
6	4214-006	Hex. Screw M8x8	1
7	4214-007	Hex. Bolt M16x35	1
8	4214-008	Support Column	1
9	4214-009	Table Arm	1
10	4214-010	Lock Knob	2
11	4214-011	Hex. Bolt M10x30	4
12	4214-012	Handlebar Assembly	1
13	4214-013	Nut	1
14	4214-014	Crank	1
15	4214-015	Hex. Screw M6x10	1
16	4214-016	Worm	1
17	4214-017	Gear Pin	1
18	4214-018	Gear Helical	1
19	4214-019	Table Support	1
20	4214-020	Table	1
21	4214-021	Guide Bar	2
22	4214-022	Screw	2
23	4214-023	Roller Support	1
24	4214-024	Screw	2
25	4214-025	Roller	1
26	4214-026	Rack	1
27	4214-027	Column Tube	1
28	4214-028	Hex Screw M8x10	2
29	4214-029	Chuck Key	1
30	4214-030	Chuck	1
31	4214-031	Chuck Arbor	1
32	4214-032	Spindle	1
33	4214-033	Screw	1
34	4214-034	Ball Bearing	1
35	4214-035	Lock Collar	1
36	4214-036	Nut	1
37	4214-037	Lock Nut	2
38	4214-038	Quill	1
39	4214-039	Lock-depth Bolt	1
40	4214-040	Quill Gasket	1
41	4214-041	Ball Bearing	1
42	4214-042	Retaining Ring	1
43	4214-043	Screw	1
44	4214-044	lock Washer	1

Item#	Part#	Description	Qty
45	4214-045	Spring	1
46	4214-046	Shaft	1
47	4214-047	Laser Beam Device	2
48	4214-048	Bulb	1
49	4214-049	Pan Head ScrewM3x8	1
50	4214-050	Lamp Assembly	1
51	4214-051	Socket Support	1
52	4214-052	Handle Knob	4
53	4214-053	Handle	3
54	4214-054	Hub	1
55	4214-055	Pin	1
56	4214-056	Scale	1
57	4214-057	Pinion Shaft	1
58	4214-058	Hex. Bolt M8x25	4
59	4214-059	Washer	11
60	4214-060	Motor	1
61	4214-061	Key	1
62	4214-062	Hex. Bolt M8x12	3
63	4214-063	Motor Mount	1
64	4214-064	Pin	2
65	4214-065	Screw	2
66	4214-066	Hex Screw M8x8	2
67	4214-067	Hex Screw M6x8	4
68	4214-068	Head	1
69	4214-069	Shaft	1
70	4214-070	Shaft Plate	1
71	4214-071	Screw	6
72	4214-072	pothook	1
73	4214-073	Cord Clamp	3
74	4214-074	Ball Bearing	2
75	4214-075	Retaining Ring	1
76	4214-076	Spacer	1
77	4214-077	Pulley Insert	1
78	4214-078	Key	1
79	4214-079	Hex Nut M12	2
80	4214-080	Spring Cover	1
81	4214-081	Coil Spring	1
82	4214-082	Hex Nut M8	2
83	4214-083	Retaining Spring	1
84	4214-084	Socket Set Screw	1
85	4214-085	Pan Head ScrewM5x6	2
86	4214-086	Washer	2
87	4214-087	Pan Head ScrewM5x14	3
88	4214-088	Digital Screen	1

Parts list (continued)

Item#	Part#	Description	Qty
89	4214-089	Switch Box	1
90	4214-090	Key Switch	1
91	4214-091	Light Switch	2
92	4214-092	Adjust Nut	2
93	4214-093	Washer	1
94	4214-094	Key	1
95	4214-095	Handle Seat	1
96	4214-096	Self-lock Nut	1
97	4214-097	Butter Spring	1
98	4214-098	Washer Foam	4
99	4214-099	Bushing Rubber	3
100	4214-100	Nut M5	2
101	4214-101	Receiver Seat	1
102	4214-102	Receiver	1
103	4214-103	Nut M4	6
104	4214-104	Self-tapping Screw	4
105	4214-105	Pulley Cover	1
106	4214-106	Raster	1
107	4214-107	Spindle Pulley	1
108	4214-108	Spring Seat	1
109	4214-109	Motor Pulley Spring	1
110	4214-110	Spring Cover	1
111	4214-111	V-Belt	1
112	4214-112	Motor Pulley	1
113	4214-113	Spindle Pulley	1

Item#	Part#	Description	Qty
114	4214-114	Retaining Ring	1
115	4214-115	Ball Bearing	1
116	4214-116	Cam	1
117	4214-117	Retaining Ring	1
118	4214-118	Retaining Ring	1
119	4214-119	Motor Pulley	1
120	4214-120	Power Cord (Ame)	1
121	4214-121	Motor Cord	1
122	4214-122	Allen Wrench	1
123	4214-123	Allen Wrench	1
124	4214-124	Rack Collar	1
125	4214-125	Pin	1
126	4214-126	Key Chuck Clip	1
127	4214-127	Tying Band	1
128	4214-128	Wrench	1
129	4214-129	Wedge	1
130	4214-130	Wing Nut	1
131	4214-131	Vice-baffle	1
132	4214-132	Square Neck Bolt	1
133	4214-133	Tighten Handle	2
134	4214-134	Bracket Scale	1
135	4214-135	Bracket Indicator	1
136	4214-136	Washer	5
137	4214-137	Pan Head Screw	5

Exploded view

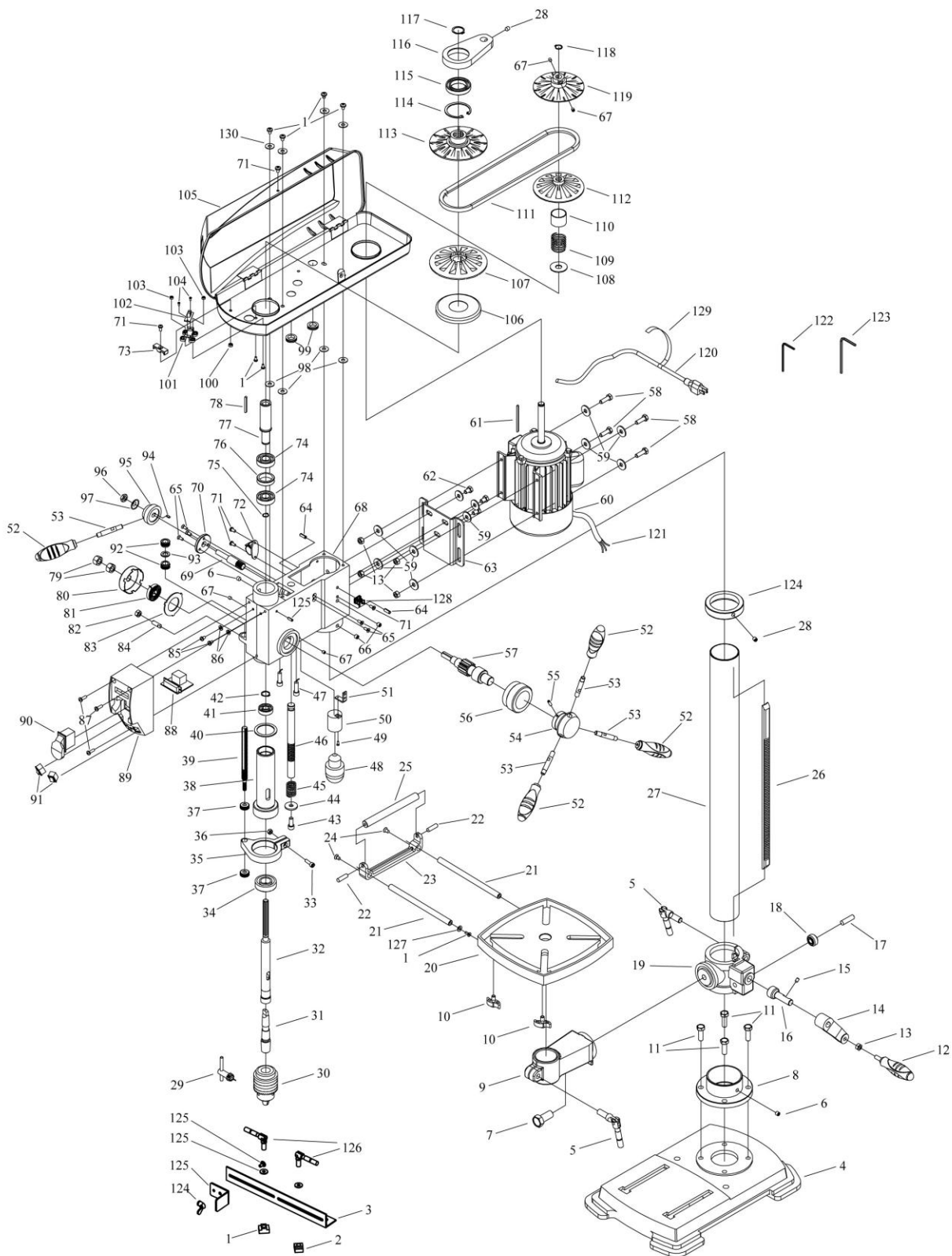

Two years limited warranty

WEN[®] is committed to building tools that are dependable for years. Our warranties are consistent with our commitment and dedication to quality.

TWO (2) YEARS LIMITED WARRANTY OF WEN PRODUCTS FOR HOME USE.

GREAT LAKES TECHNOLOGIES, LLC ("Seller") warrants to the original purchaser only, that all WEN consumer power tools will be free from defects in material or workmanship for a period of two (2) years from date of purchase. Ninety (90) days for all WEN Products, if the tool is used for professional or commercial use.

SELLER'S SOLE OBLIGATION AND YOUR EXCLUSIVE REMEDY under this Two (2) Years Limited Warranty and, to the extent permitted by law, any warranty or condition implied by law, shall be the repair or replacement of parts, without charge, which are defective in material or workmanship and which have not been misused, carelessly handled, or misrepaired by persons other than Seller or Authorized Service Center. To make a claim under this Limited Warranty, you must return the entire power tool product; transportation prepaid, to Great Lakes Technologies, LLC-1675 Holmes Road, Elgin IL 60123. Include a legible copy of the original receipt, which lists the date of purchase (month and year) and the name of the company purchased from.

THIS LIMITED WARRANTY DOES NOT APPLY TO ANY ACCESSORY ITEMS INCLUDED WITH THE TOOL SUCH AS CIRCULAR SAW BLADES OTHER RELATED ITEMS OR TO ANY REPLACEMENT PARTS LISTED UNDER MAINTENANCE.

ANY IMPLIED WARRANTIES SHALL BE LIMITED IN DURATION TO TWO (2) YEARS FROM DATE OF PURCHASE. SOME STATES IN THE U.S. AND SOME CANADIAN PROVINCES DO NOT ALLOW LIMITATIONS ON HOW LONG AN IMPLIED WARRANTY LASTS, SO THE ABOVE LIMITATION MAY NOT APPLY TO YOU.

IN NO EVENT SHALL SELLER BE LIABLE FOR ANY INCIDENTAL OR CONSEQUENTIAL DAMAGES (INCLUDING BUT NOT LIMITED TO LIABILITY FOR LOSS OF PROFITS) ARISING FROM THE SALE OR USE OF THIS PRODUCT. SOME STATES IN THE U.S. AND SOME CANADIAN PROVINCES DO NOT ALLOW THE EXCLUSION OR LIMITATION OF INCIDENTAL OR CONSEQUENTIAL DAMAGES, SO THE ABOVE LIMITATION OR EXCLUSION MAY NOT APPLY TO YOU.

THIS LIMITED WARRANTY GIVES YOU SPECIFIC LEGAL RIGHTS, AND YOU MAY ALSO HAVE OTHER RIGHTS WHICH VARY FROM STATE TO STATE IN THE U.S., PROVINCE TO PROVINCE IN CANADA AND FROM COUNTRY TO COUNTRY.

THIS LIMITED WARRANTY APPLIES ONLY TO PORTABLE ELECTRIC TOOLS, BENCH POWER TOOLS, OUTDOOR POWER EQUIPMENT AND PNEUMATIC TOOLS SOLD WITHIN THE UNITED STATES OF AMERICA, CANADA AND THE COMMONWEALTH OF PUERTO RICO. FOR WARRANTY COVERAGE WITHIN OTHER COUNTRIES, CONTACT WEN CUSTOMER SUPPORT.

For questions / comments, technical assistance or repair parts –
Please Call Toll Free at: 1-800-232-1195 (M-F 8am – 5pm) CST

SAVE YOUR RECEIPTS. THIS WARRANTY IS VOID WITHOUT THEM.

